

RoHS Compliant

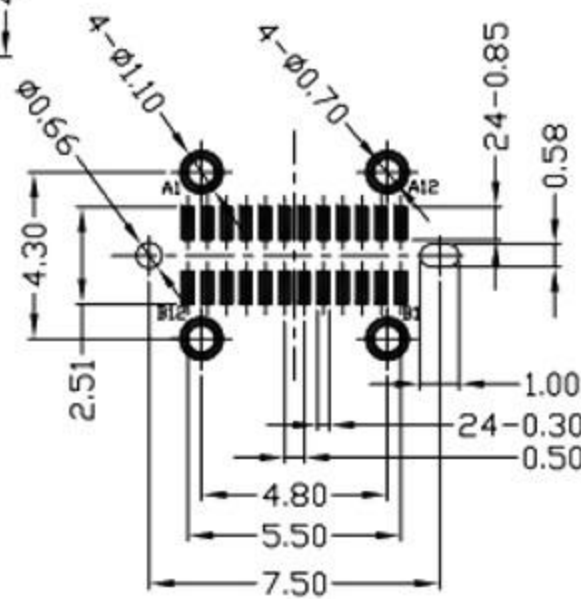
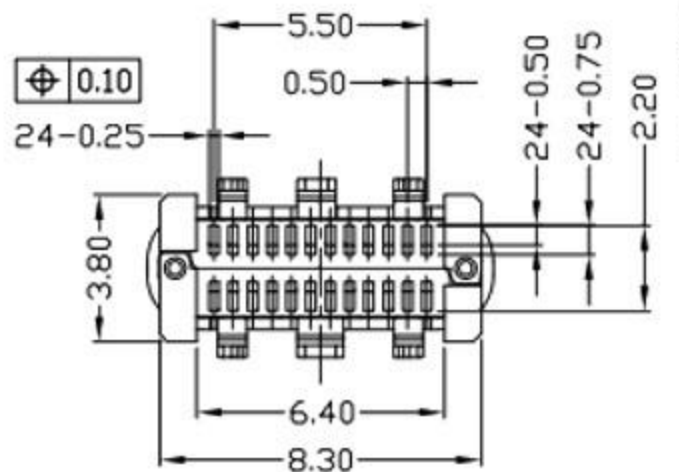
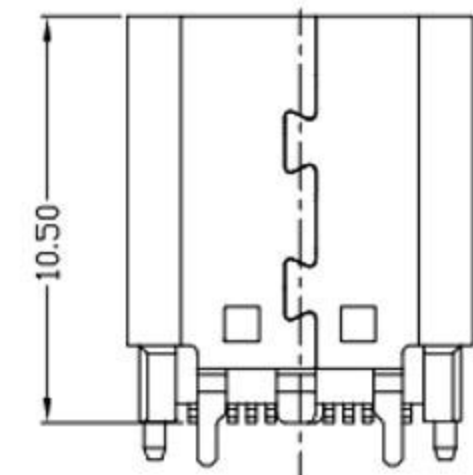
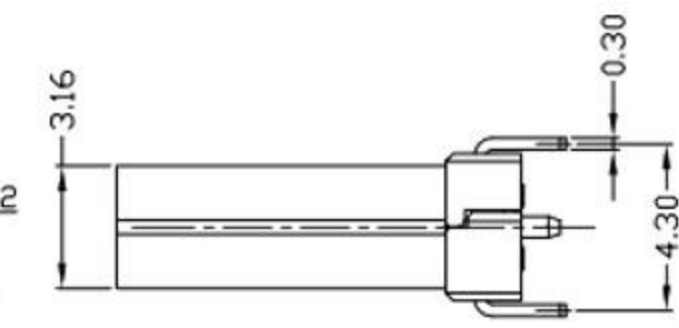
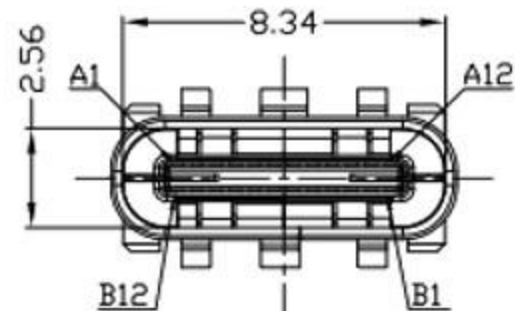
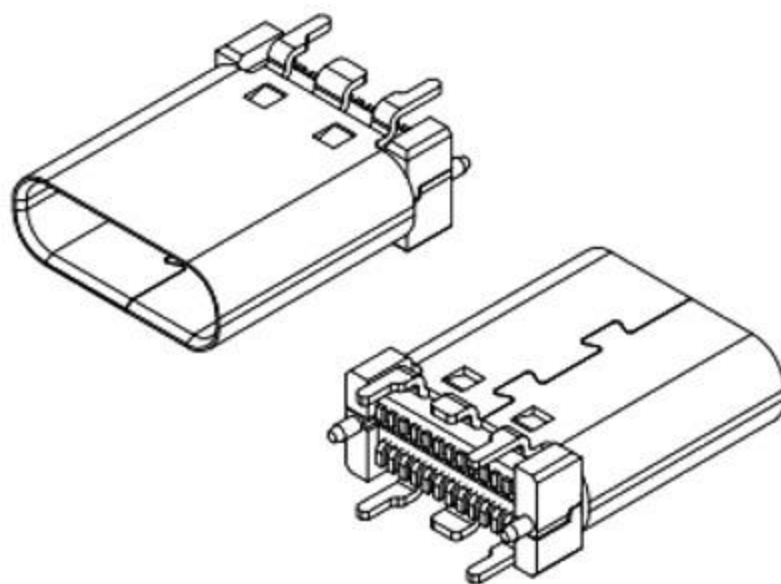
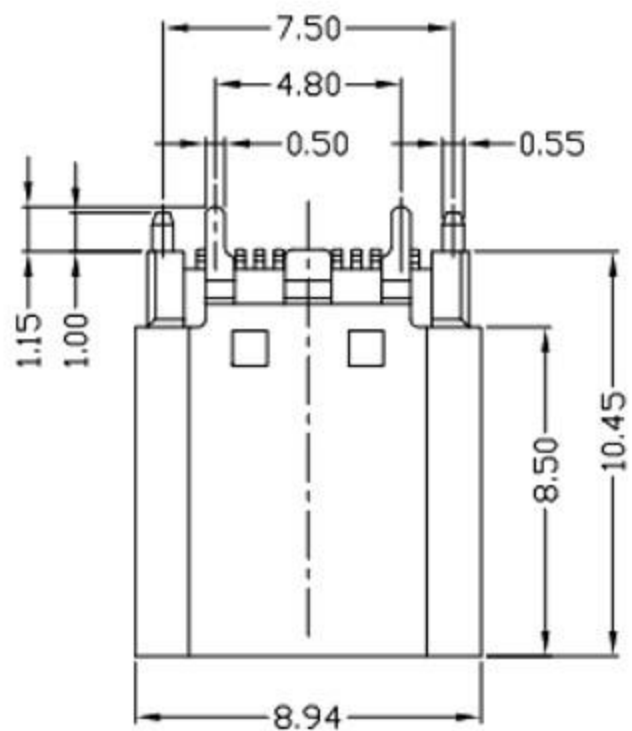

NOTES:

- ELECTRICAL:
 - CURRENT RATING: 3A MIN FOR VBUS; VOLTAGE: 5VAC MAX 0.25A MIN FOR OTHER.
 - INSULATION RESISTANCE: 100MΩ MIN;
 - CONTACT RESISTANCE: 40mΩ MAX;
 - WITHSTANDING VOLTAGE: 100V AC;
 - OPERATING TEMPERATURE: -30°C ~ +80°C.
- Mechanical:
 - INSERTION FORCE: 5~20N.
 - EXTRACTION FORCE: 8~20N.
- DIMENSIONS MARKED "▼" TO BE CHECKED BY Q.C & IPQC.
- PART NO.

1: Au 1U*	1: PBT
2: Au 3U*	2: PA6T
5: Au 15U*	3: PA9T
6: Au 30U*	4: LCP
	W: WHITE
	B: BLACK

USB TYPE-C FULL-FEATURED RECEPTACLE INTERFACE PIN ASSIGNMENTS

A1	GND	B12	GND
A2	SSTXP1	B11	SSRXP1
A3	SSTXN1	B10	SSRXN1
A4	VBUS	B9	VBUS
A5	CC1	B8	SBU2
A6	DP1	B7	DN2
A7	DN1	B6	DP2
A8	SBU1	B5	CC2
A9	VBUS	B4	VBUS
A10	SSRXN2	B3	SSTXN2
A11	SSRXP2	B2	SSTXP2
A12	GND	B1	GND
PIN	SIGNAL NAME	PIN	SIGNAL NAME

⑤	MID PLATE	1	STAINLESS STEEL	Au . PLATING.	T=0.15mm
④	SHELL	1	STAINLESS STEEL	Au . PLATING.	T=0.30mm
③	TERMINAL-B	1	TABLE 2:	TABLE 2:	T=0.12mm
②	TERMINAL-A	1	TABLE 2:	TABLE 2:	T=0.12mm
①	INSULATOR	1	HIGH TEMP	Black	

NO.	PART NAME	QTY	MATERIAL	DESCRIPTION	REMARK
-----	-----------	-----	----------	-------------	--------

UNLESS OTHERWISE, GENERAL TOLERANCE:
 X.xxx ±0.10
 X.xx ±0.20
 X.x ±0.30
 X. ±0.38
 ANGULAR:
 X.xx ±1°
 X.x ±3°
 X. ±5°

廣東科斯達電子科技有限公司

TITLE:	P/N: Detail See PART NO. LIST			
USB connector	MODEL:			
	DRAW NO.:			
THIRD ANGLE PROJECTION	UNIT:	SCALE:	SIZE:	SHEET:
	mm	1:1	A4	1/1

JH2016-080	X2	隨工程圖上升版本次	2016.06.15	陳少兵	DESIGN	陳少兵	2016.06.15
JH2016-071	X1	新增規格	2016.06.10	陳少兵	CHECK	鄭小偉	2016.06.15
20151224001	X	NEW DRAWING	2016.05.05	陳少兵	APPROVAL	呂海濤	2016.06.15
ECN NO.	REV.	DESCRIPTION	DATE	CHANGE			