

REV.	ECN. NO.	APPD.

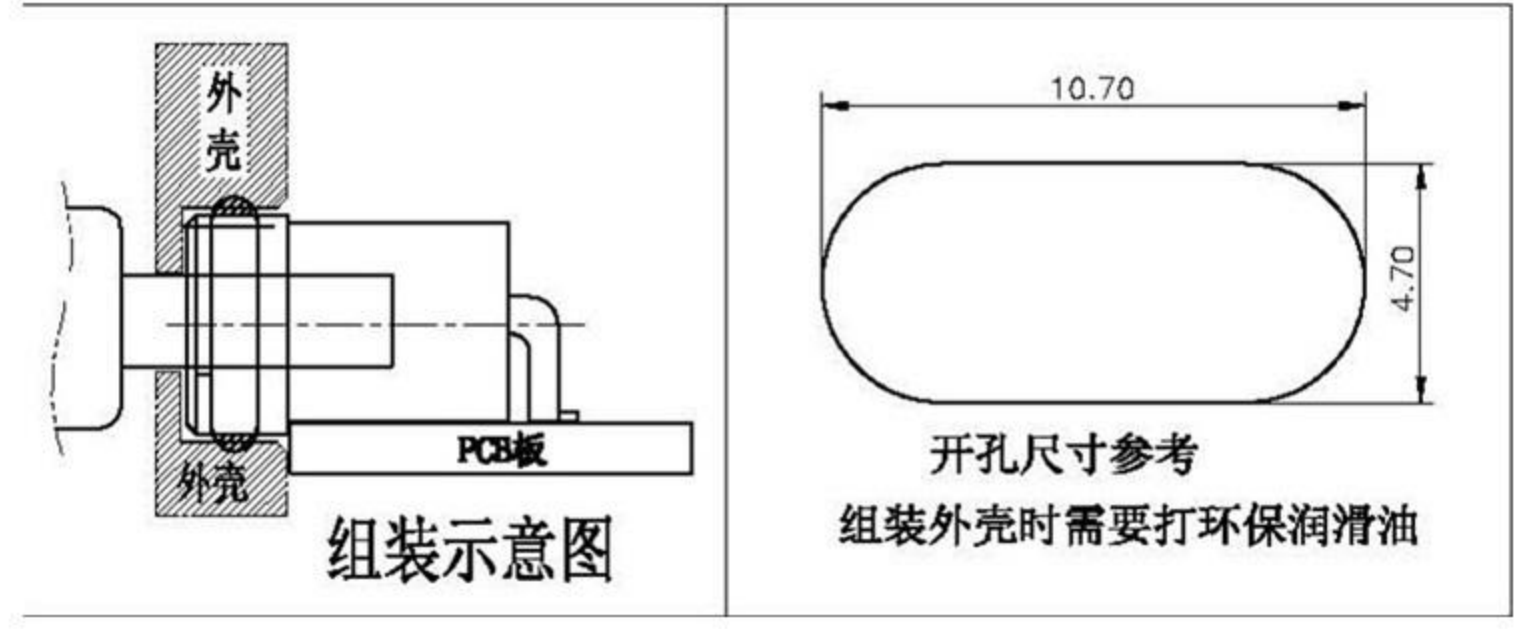
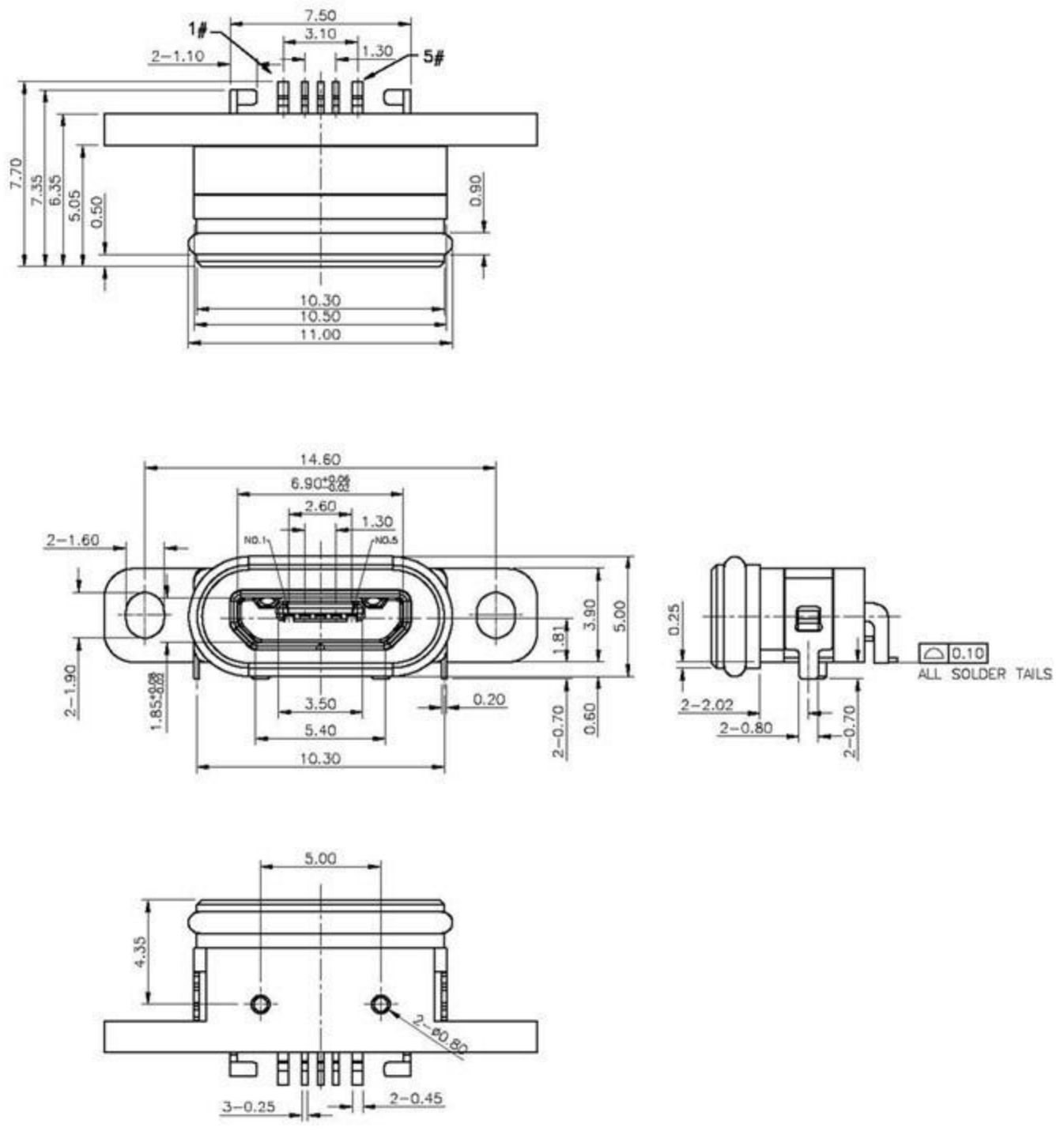

组装示意图

开孔尺寸参考  
组装外壳时需要打环保润滑油

NOTES:

SPECIFICATION:

- CURRENT RATING: 3.0A MAX
- DIELECTRIC WITHSTAND VOLTAGE: 100VAC
- TEMPERATURE RANGE: -30 °C ~ 85 °C
- CONTACT RESISTANCE: 40 MILLIONHM MAX
- INSULATION RESISTANCE: 100 MEGOHMS MIN.
- INSERTION FORCE :8N~35N
- UNMATING FORCE: 8N~35N
- DURABILITY:1500 CYCLES

ITEM	PART NAME	Q'TY	FINISH	NOTE
3	Shell	1	SUS 301 1/4H	
3	PLASTIC Shell	1	PA9T&LCP (G.F30%)	
2	Contact	4	BRASS C2680-EH Au/Ni Plating T=0.25mm	
1	Housing	1	PA10T (G.F30%)	

X. ±0.50	X.* ±2°	UNITS mm	廣東科斯達電子科技有限公司		
.X ±0.30	.X* ±1°				
.XX ±0.10	.XX* ±0.5°	MAT'L	PART NO.	TITLE: IP68	
.XXX ±0.05					
THESE DRAWINGS AND SPECIFICATIONS ARE THE PROPERTY OF E-ZONE ELECTRONIC TECHNOLOGY CO.,LTD.AND SHALL NOT BE REPRODUCED, COPIED OR USED IN ANY MANNER WITHOUT THE PRIOR WRITTEN CONSENT OF E-ZONE ELECTRONIC TECHNOLOGY CO., LTD			FINISH	APPD: RADDM	DWG NO.: <b>USB connector</b>
			Q'TY	CHKD: MARK	
			DR: JANE CHOU 2019/07/11		
			SCALE	SHEET	REV.
			1/1	1/2	A2