

|      |          |       |
|------|----------|-------|
| REV. | ECN. NO. | APPD. |
|      |          |       |

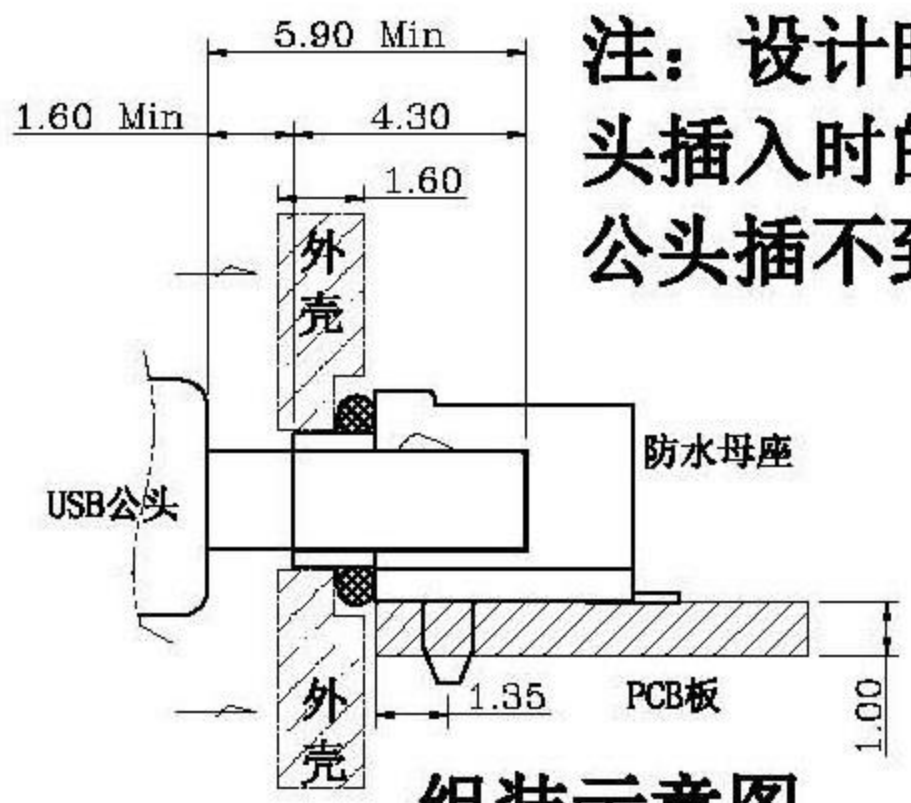

**注：设计时，请注意公头插入时的距离，防止公头插不到底。**

**组装示意图**

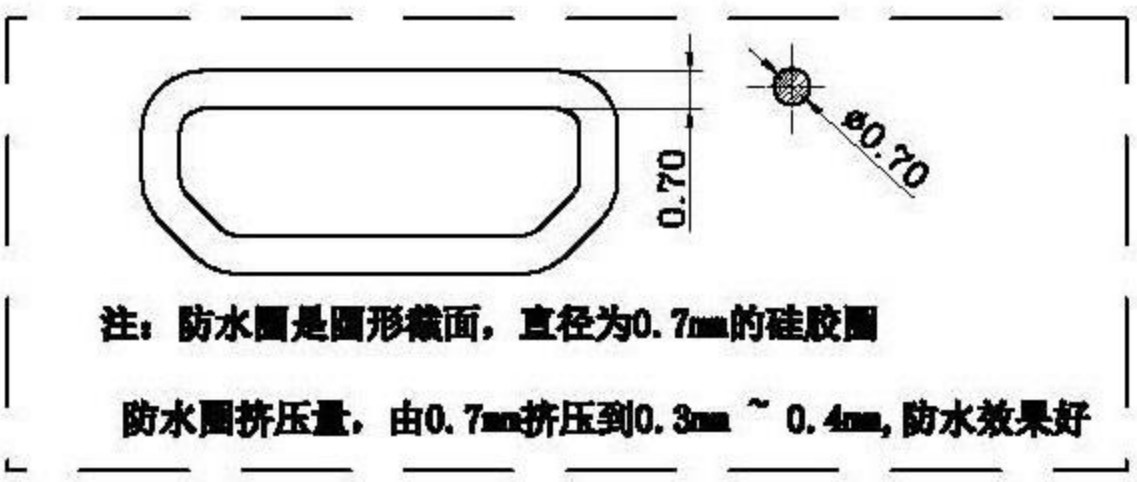

**注：防水圈是圆形截面，直径为0.7mm的硅胶圈**  
**防水圈挤压量，由0.7mm挤压到0.3mm ~ 0.4mm，防水效果好**

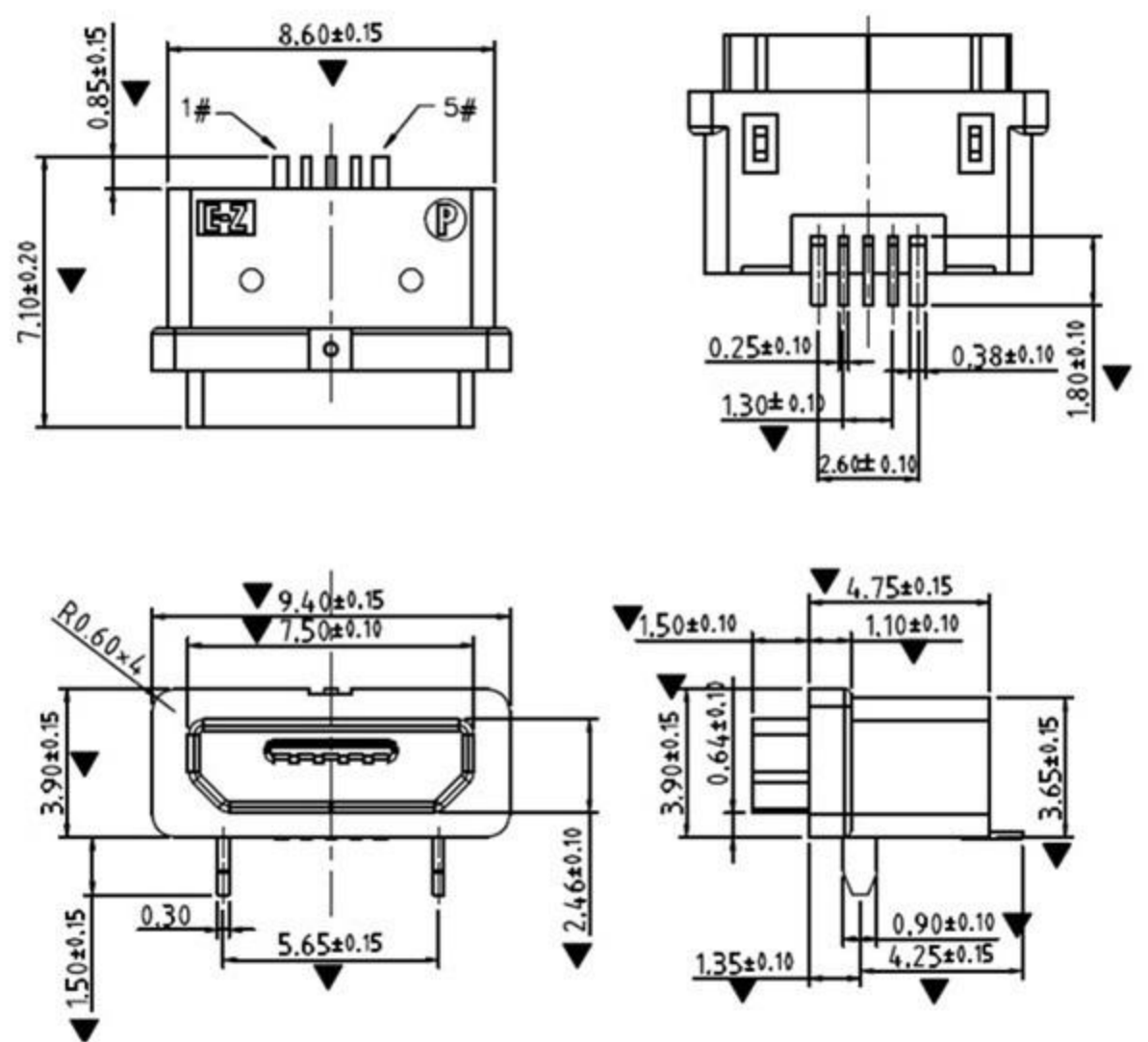

**NOTES:**

**SPECIFICATION:**

1. CURRENT RATING: 3.0A MAX
2. DIELECTRIC WITHSTAND VOLTAGE: 100VAC
3. TEMPERATURE RANGE: -30 °C ~ 85 °C
4. CONTACT RESISTANCE: 40 MILLIONHM MAX
5. INSULATION RESISTANCE: 100 MEGOHMS MIN.
6. INSERTION FORCE :8N~35N
7. UNMATING FORCE: 8N~35N
8. DURABILITY:1500 CYCLES

| ITEM | PART NAME     | Q'TY | FINISH                                   | NOTE |
|------|---------------|------|--|------|
| 3    | Shell         | 1    | SUS 301 1/4H                             |      |
| 3    | PLASTIC Shell | 1    | PA9T&LCP (G.F30%)                        |      |
| 2    | Contact       | 4    | BRASS C2680-EH<br>Au/Ni Plating T=0.25mm |      |
| 1    | Housing       | 1    | PA10T (G.F30%)                           |      |

|   |            |             |                      |                      |      |                          |
|---|------------|-------------|----------------------|----------------------|------|--------------------------|
| X. ±0.50  | X.* ±2°    | UNITS<br>mm | <b>廣東科斯達電子科技有限公司</b> |                      |      |                          |
| .X ±0.30  | .X* ±1°    |             |                      |                      |      |                          |
| .XX ±0.10   | .XX* ±0.5° | MAT'L       | PART NO.             | TITLE:<br>IP68       |      |                          |
| .XXX ±0.05  |            |             |                      |                      |      |                          |
| THESE DRAWINGS AND SPECIFICATIONS ARE THE PROPERTY OF E-ZONE ELECTRONIC TECHNOLOGY CO.,LTD.AND SHALL NOT BE REPRODUCED, COPIED OR USED IN ANY MANNER WITHOUT THE PRIOR WRITTEN CONSENT OF E-ZONE ELECTRONIC TECHNOLOGY CO., LTD |            |             | APPD: RADDM          | <b>USB connector</b> |      |                          |
|   |            |             | FINISH               |                      |      | CHKD: MARK               |
|   |            |             | Q'TY                 |                      |      | DR: JANE CHOU 2019/07/11 |
|   |            |             | SCALE                | SHEET                | REV. |                          |
|   |            |             | 1/1                  | 1/2                  | A2   |                          |