

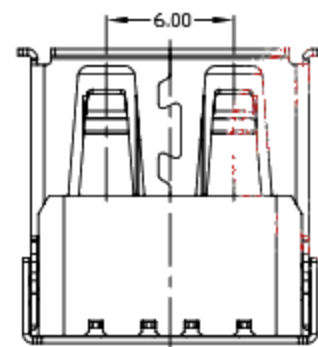

RoHS
Compliant
2002/95/EC

REV.	ECN. NO.	APPD.

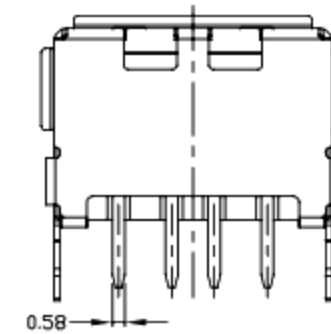
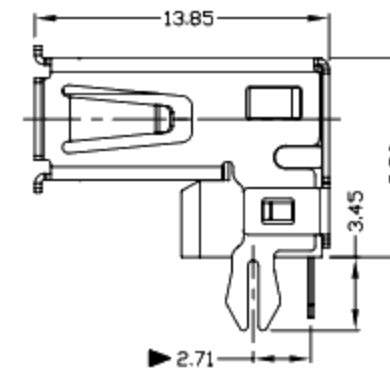
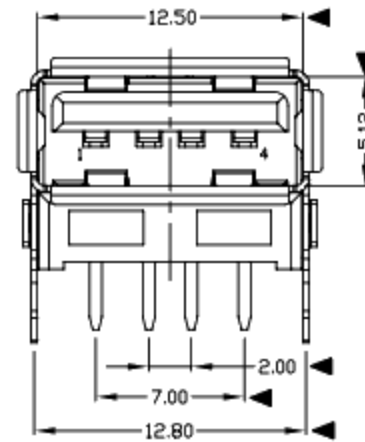
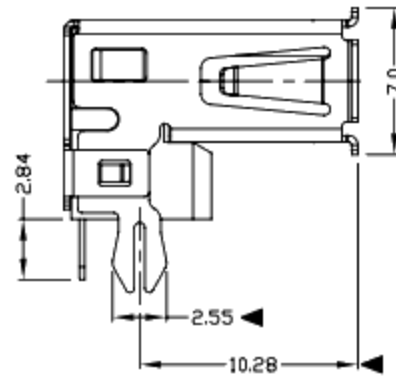
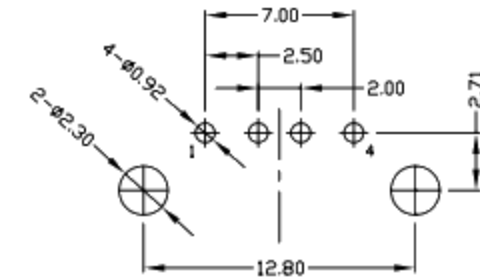
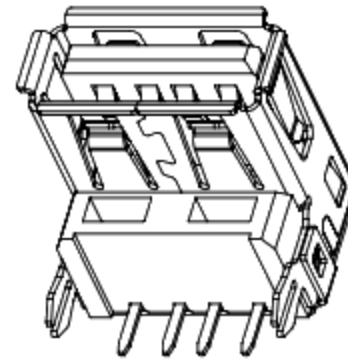
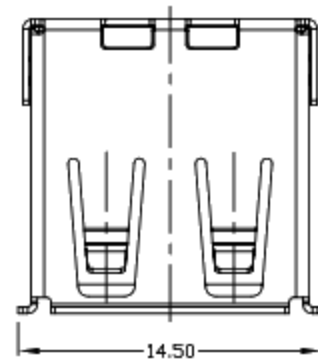

NOTES:

- ELECTRICAL:
 - VOLTAGE CURRENT RATING: 2AMP, 30V AC;
 - INSULATION RESISTANCE: 1000MΩ MIN;
 - CONTACT RESISTANCE: 30mΩ MAX;
 - WITHSTANDING VOLTAGE: 500V AC;
 - OPERATING TEMPERATURE: -55°C TO +85°C.
- Mechanical:
 - Mating Force: 35N MAX
 - Unmating Force: 10N MIN.
- NOTE: 1. DIMENSIONS MARKED "▼" TO BE CHECKED BY Q.C & IPQC.

4. PART NO.

1: Au 1U*
6: Au 30U*

W: WHITE
B: BLACK
1: PBT
2: PA6T
3: PA9T
4: LCP

Bill of materials:

NO	PARTS	MATERIAL	QTY	FINISHING
3	HOUSING	PBT+30%GF	1	UL94V-0
2	SHELL	COPPER ALLOY	1	PLATED NICKEL
1	TERMINAL	COPPER ALLOY	4	PLATED GOLD/TIN

X. ±0.35	X.* ±2'	UNITS	mm
.X ±0.3	.X.* ±1'	MAT'L	SEE NOTE
.XX ±0.25	.XX.*	FINISH	SEE NOTE
.XXX ±0.15	.XXX.*	Q'TY	SEE NOTE

THESE DRAWINGS AND SPECIFICATIONS ARE THE PROPERTY OF ACCURATE INNOTECH INC AND SHALL NOT BE REPRODUCED, COPIED OR USED IN ANY MANNER WITHOUT THE PRIOR WRITTEN CONSENT OF ACCURATE INNOTECH INC.

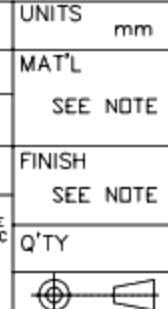

廣東科斯達電子科技有限公司

TITLE: USB A/F 90° DIP 加高型	PART NO.:
DR: Ricky 2014/04/10	DWG NO.:
CHKD: Ricky 2014/04/10	SCALE: 1:1
APPD:	SHEET: 1/1
	REV: B
	CUSTOMER DRAWING