

A
B
C
D
E

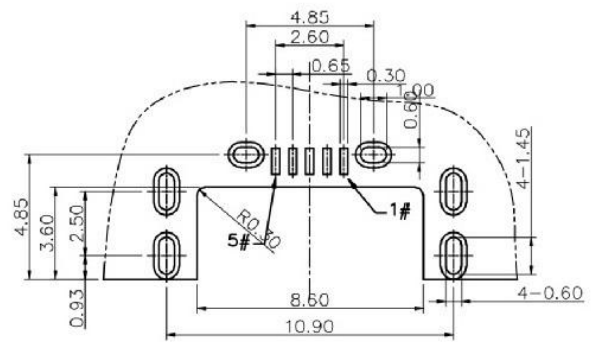
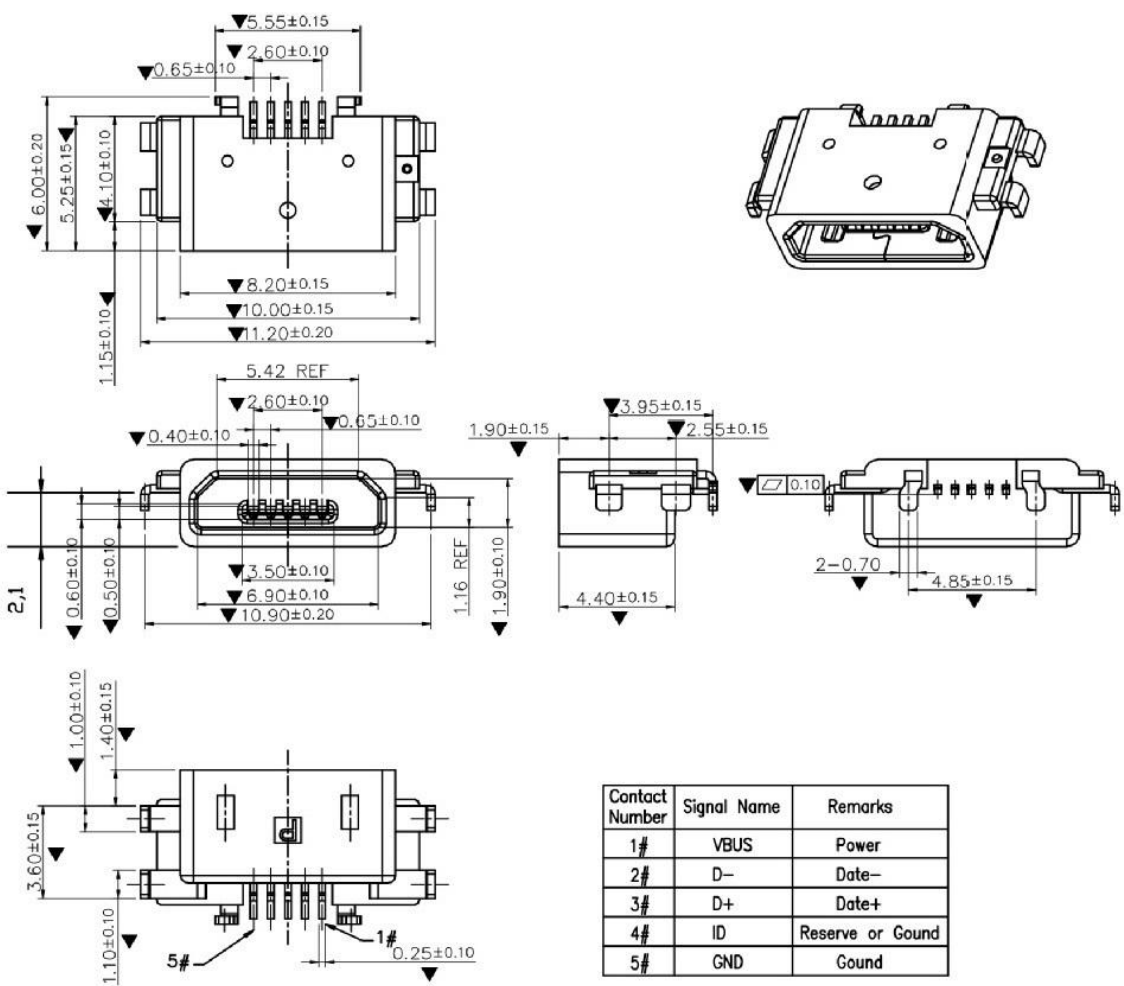

P.C.B LAYOUT

Contact Number	Signal Name	Remarks
1#	VBUS	Power
2#	D-	Date-
3#	D+	Date+
4#	ID	Reserve or Gound
5#	GND	Gound

NOTES:
SPECIFICATION:

- CURRENT RATING: 3.0A MAX
- DIELECTRIC WITHSTAND VOLTAGE: 100VAC
- TEMPERATURE RANGE: -30 °C ~ 85 °C
- CONTACT RESISTANCE: 40 MILLIONHM MAX
- INSULATION RESISTANCE: 100 MEGOHMS MIN.
- INSERTION FORCE :8N~35N
- UNMATING FORCE: 8N~35N
- DURABILITY:1500 CYCLES

ITEM	PART NAME	Q'TY	FINISH	NOTE
3	Shell	1	SUS 301 1/4H	
3	PLASTIC Shell	1	PA9T&LCP (G.F30%)	
2	Contact	4	BRASS C2680-EH Au/Ni Plating T=0.25mm	
1	Housing	1	PA10T (G.F30%)	

X. ±0.50	X.* ±2*	UNITS mm	广东科斯达电子科技有限公司 KSDKG Guangdong Keside Electronic Technology Co., Ltd.							
.X ±0.30	.X* ±1*									
.XX ±0.10	.XX* ±0.5*	MAT'L	PART NO.							
.XXX ±0.05			TITLE: IP68							
THESE DRAWINGS AND SPECIFICATIONS ARE THE PROPERTY OF E-ZONE ELECTRONIC TECHNOLOGY CO.,LTD.AND SHALL NOT BE REPRODUCED, COPIED OR USED IN ANY MANNER WITHOUT THE PRIOR WRITTEN CONSENT OF E-ZONE ELECTRONIC TECHNOLOGY CO., LTD.		FINISH	APPD: RADDOM	DWG NO: USB connector						
			Q'TY		CHKD: MARK					
			DR: JANE CHOU 2019/07/11	<table border="1"> <tr> <td>SCALE</td> <td>SHEET</td> <td>REV.</td> </tr> <tr> <td>1/1</td> <td>1/2</td> <td>A2</td> </tr> </table>	SCALE	SHEET	REV.	1/1	1/2	A2
SCALE	SHEET	REV.								
1/1	1/2	A2								