

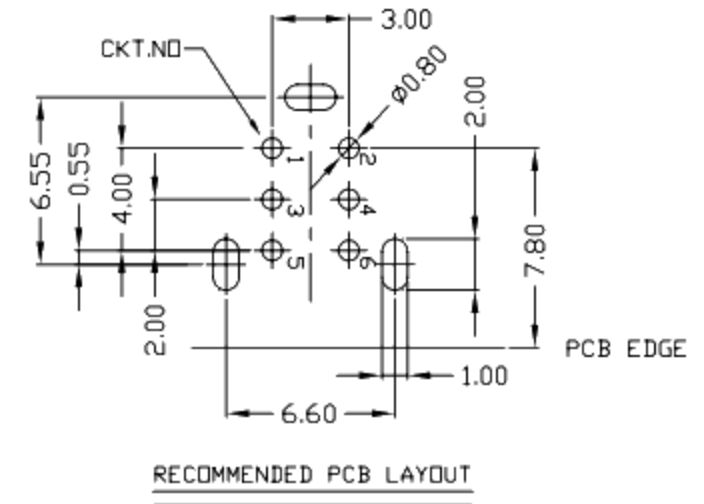

RoHS
Compliant
2002/95/EC

REV.	ECN. NO.	APPD.

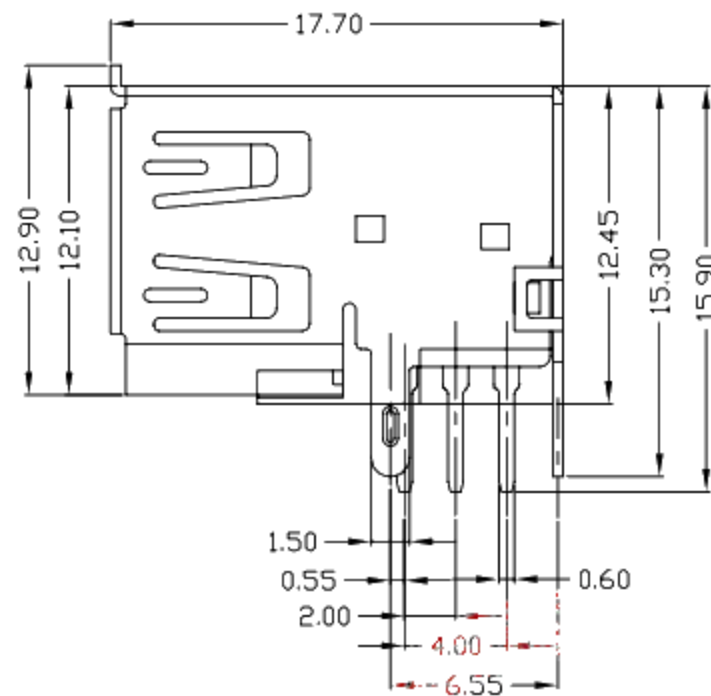
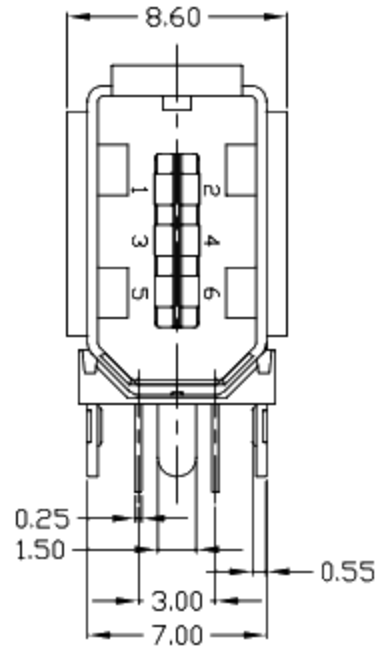
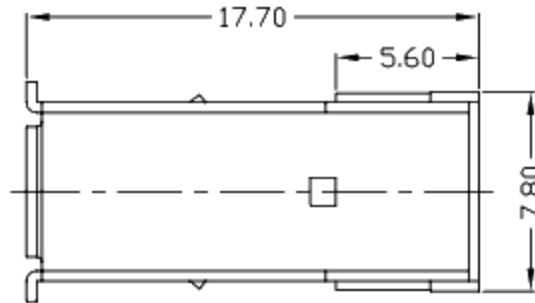

NOTES:

- ELECTRICAL:
 - VOLTAGE CURRENT RATING: 1AMP, 30V AC;
 - INSULATION RESISTANCE: 1000MΩMIN;
 - CONTACT RESISTANCE: 30mΩMAX;
 - WITHSTANDING VOLTAGE: 500V AC;
 - OPERATING TEMPERATURE: -55°C TO +85°C.
- Mechanical:
 - Mating Force: 35N MAX
 - Unmating Force: 10N MIN.
- DIMENSIONS MARKED "▼" TO BE CHECKED BY Q.C & IPQC.

4. PART NO.

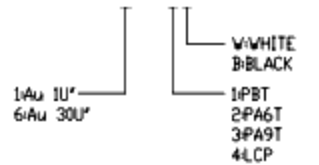

Bill of materials:

NO	PARTS	MATERIAL	QTY	FINISHING	X. ±0.35	X.* ±2*	UNITS	mm
3	HOUSING	PBT+30%GF	1	UL94V-0	.X ±0.3	.X* ±1*	MAT'L	
2	SHELL	COPPER ALLOY	1	PLATED NICKEL	.XX ±0.25	.XX*	SEE NOTE	
1	TERMINAL	COPPER ALLOY	6	PLATED GOLD/TIN	.XXX ±0.15	.XXX*	FINISH	
							SEE NOTE	
							Q'TY	

廣東科斯達電子科技有限公司

TITLE: 1394 6P F90度側立式(一边)

PART NO.:

DR: gan 2014/09/20

CHKD: gan 2014/09/20

APPD:

DWG NO.:

SCALE: 1:1

SHEET: 1/1

REV: B

CUSTOMER DRAWING

THESE DRAWINGS AND SPECIFICATIONS ARE THE PROPERTY OF ACCURATE INNOTECH INC. AND SHALL NOT BE REPRODUCED, COPIED OR USED IN ANY MANNER WITHOUT THE PRIOR WRITTEN CONSENT OF ACCURATE INNOTECH INC.