

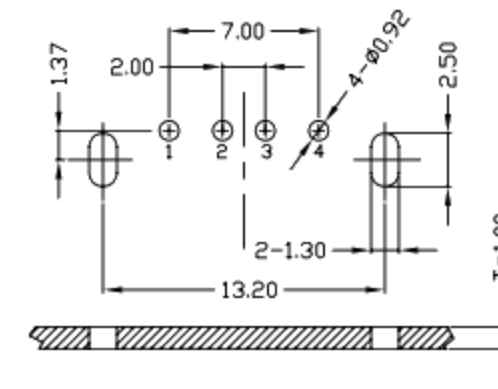

RoHS
Compliant
2002/95/EC

REV.	ECN.	NO.	APPD.

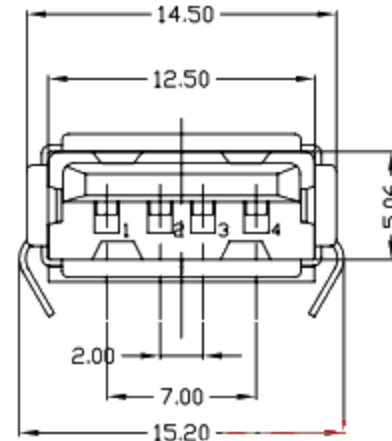
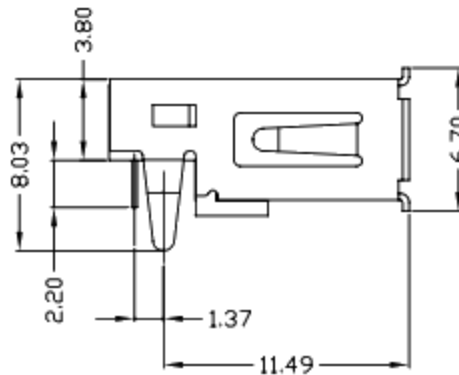
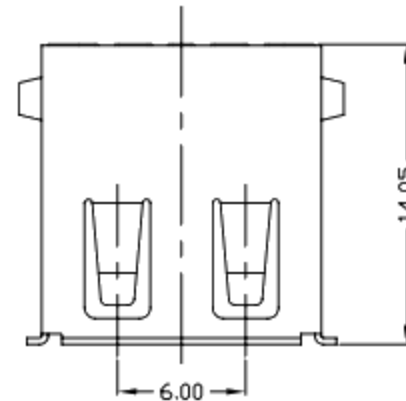

RECOMMENDED PCB LAYOUT

NOTES:

- ELECTRICAL:
 - VOLTAGE CURRENT RATING: 2AMP, 30V AC;
 - INSULATION RESISTANCE: 1000MΩMIN;
 - CONTACT RESISTANCE: 30mΩMAX;
 - WITHSTANDING VOLTAGE: 500V AC;
 - OPERATING TEMPERATURE: -55°C TO +85°C.
- Mechanical:
 - Mating Force: 35N MAX
 - Unmating Force: 10N MIN.
- DIMENSIONS MARKED "▼" TO BE CHECKED BY Q.C & IPQC.

4. PART NO.



Bill of materials:

NO	PARTS	MATERIAL	QTY	FINISHING
3	HOUSING	PBT+30%GF	1	UL94V-0
2	SHELL	COPPER ALLOY	1	PLATED NICKEL
1	TERMINAL	COPPER ALLOY	4	PLATED GOLD/TIN

X.	±0.35	X.* ±2*	UNITS	mm
.X	±0.3	.X* ±1*	MAT'L	SEE NOTE
.XX	±0.25	.XX*	FINISH	SEE NOTE
.XXX	±0.15	.XXX*	Q'TY	SEE NOTE

THESE DRAWINGS AND SPECIFICATIONS ARE THE PROPERTY OF ACCURATE INNOTECH INC AND SHALL NOT BE REPRODUCED, COPIED OR USED IN ANY MANNER WITHOUT THE PRIOR WRITTEN CONSENT OF ACCURATE INNOTECH INC.

廣東科斯達電子科技有限公司

TITLE: USB AF 90° 插板式(超薄079) PART NO.:

DR: gan 2014/09/16 DWG NO.:

CHKD: gan 2014/09/16

APPD:

SCALE	SHEET	REV.	CUSTOMER DRAWING
1:1	1/1	B	