

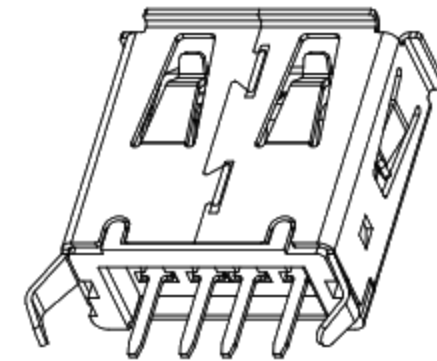

RoHS
Compliant
2002/95/EC

REV.	ECN.	NO.	APPD.

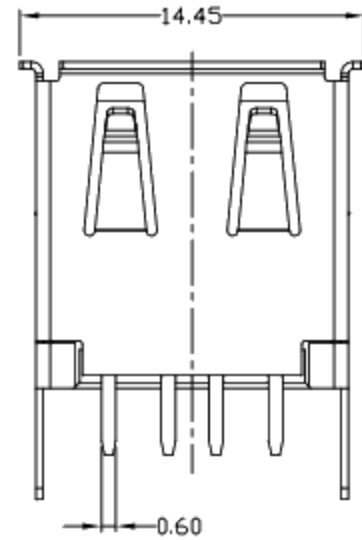
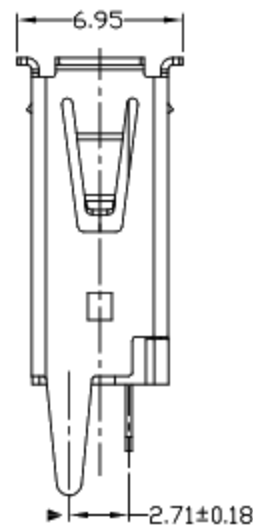
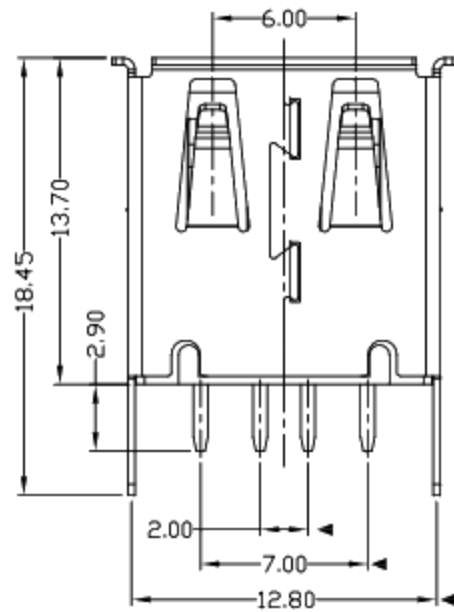
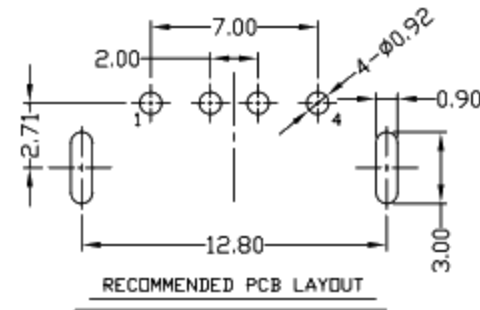
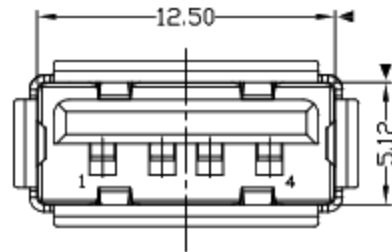

NOTES:

- ELECTRICAL:
 - VOLTAGE CURRENT RATING: 2AMP, 30V AC;
 - INSULATION RESISTANCE: 1000MΩ, MIN;
 - CONTACT RESISTANCE: 30mΩ MAX;
 - WITHSTANDING VOLTAGE: 500V AC;
 - OPERATING TEMPERATURE: -55°C TO +85°C.
- Mechanical:
 - Mating Force: 35N MAX
 - Unmating Force: 10N MIN.
- NOTE: 1. DIMENSIONS MARKED "▼" TO BE CHECKED BY Q.C & IPQC.

4. PART NO.

1-Au 10"
6-Au 30U"

W: WHITE
B: BLACK
1: PBT
2: PA6T
3: PA9T
4: LCP

Bill of materials:

NO	PARTS	MATERIAL	QTY	FINISHING
3	HOUSING	PBT+30%GF	1	UL94V-0
2	SHELL	COPPER ALLOY	1	PLATED NICKEL
1	TERMINAL	COPPER ALLOY	4	PLATED GOLD/TIN

X.	X.*	UNITS
±0.35	±2'	mm
±0.30	±1'	MAT'L
.XX ±0.25	.XX'	SEE NOTE
.XXX ±0.15	.XXX'	FINISH
		SEE NOTE

THESE DRAWINGS AND SPECIFICATIONS ARE THE PROPERTY OF ACCURATE INNTECH INC AND SHALL NOT BE REPRODUCED, COPIED OR USED IN ANY MANNER WITHOUT THE PRIOR WRITTEN CONSENT OF ACCURATE INNTECH INC.

Q'TY	UNITS
	mm
	MAT'L
	SEE NOTE
	FINISH
	SEE NOTE
	Q'TY

廣東科斯達電子科技有限公司

TITLE:	PART NO.:		
USB A/F全包直脚插板式(13.7)			
DR: gan 2012/6/30	DWG NO.:		
CHKD: gan 2012/6/30			
APPD: gan 2012/6/30			
SCALE	SHEET	REV.	CUSTOMER DRAWING
1:1	1/1	B	