

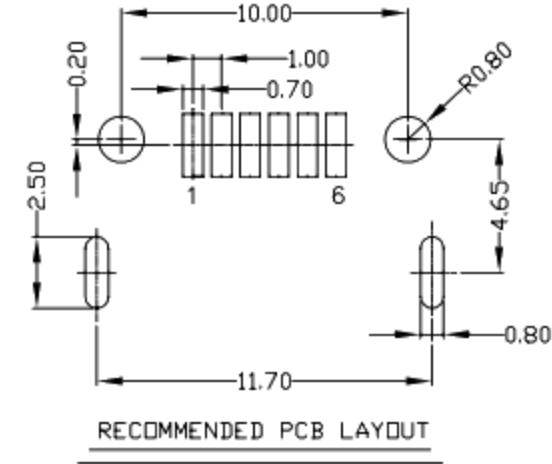

RoHS
Compliant
2002/95/EC

REV.	ECN.	NO.	APPD.

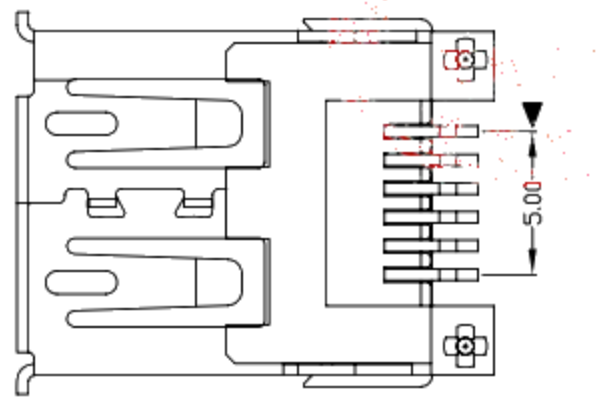
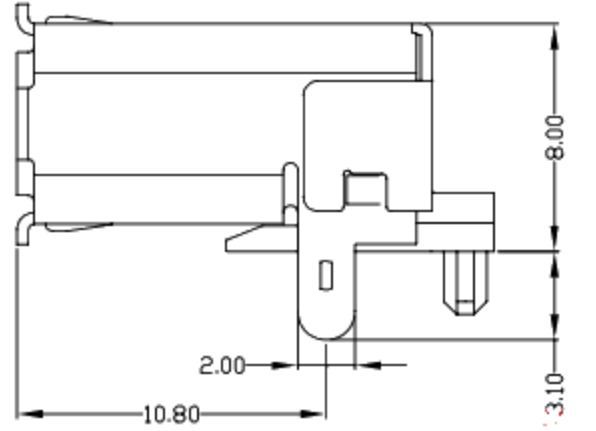
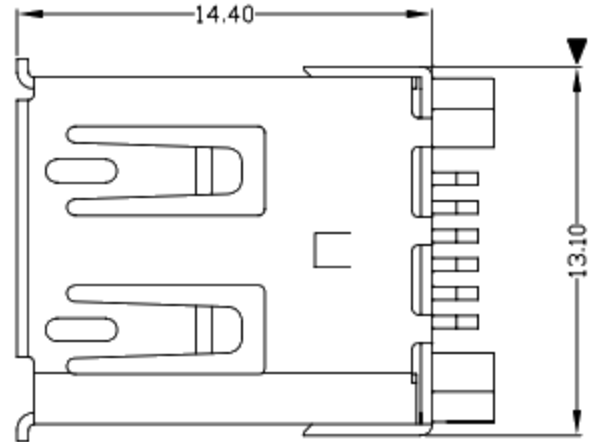
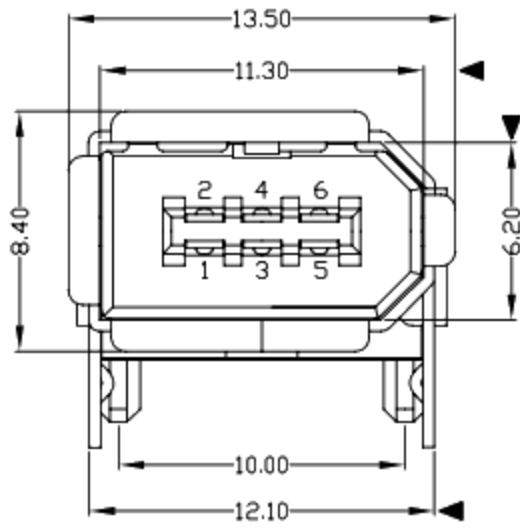

- NOTES:
- ELECTRICAL:
 - VOLTAGE CURRENT RATING: 1AMP,30V AC;
 - INSULATION RESISTANCE: 100MΩ MIN;
 - CONTACT RESISTANCE: 50mΩ MAX;
 - WITHSTANDING VOLTAGE: 300V AC;
 - OPERATING TEMPERATURE: -55°C TO +85°C.
 - Mechanical:
 - Mating Force: 30N MAX
 - Unmating Force: 7N MIN.
 - DIMENSIONS MARKED "▼" TO BE CHECKED BY Q.C & IPQC.
 - PART NO.

1: Au 1U*
6: Au 30U*

W: WHITE
B: BLACK

1: PBT
2: PA6T
3: PA9T
4: LCP

NO	PARTS	MATERIAL	QTY	FINISHING	UNITS	mm
3	HOUSING	LCP	1	UL94V-0	X. ±0.35	X.* ±2*
2	SHELL	COPPER ALLOY	1	PLATED NICKEL	.X ±0.3	.X* ±1*
1	TERMINAL	COPPER ALLOY	6	PLATED GOLD/TIN	.XXX ±0.15	.XXX*
					THESE DRAWINGS AND SPECIFICATIONS ARE THE PROPERTY OF ACCURATE INNOTECH INC AND SHALL NOT BE REPRODUCED, COPIED OR USED IN ANY MANNER WITHOUT THE PRIOR WRITTEN CONSENT OF ACCURATE INNOTECH INC.	

廣東科斯達電子科技有限公司

TITLE: IEEE 1394 6P/F SMT

PART NO.:

DR: gan 2013/01/18

CHKD: gan 2013/01/18

DWG NO.:

APPD:

SCALE	SHEET	REV.	CUSTOMER DRAWING
1:1	1/1	B	