

REV.	ECN. NO.	APPD.

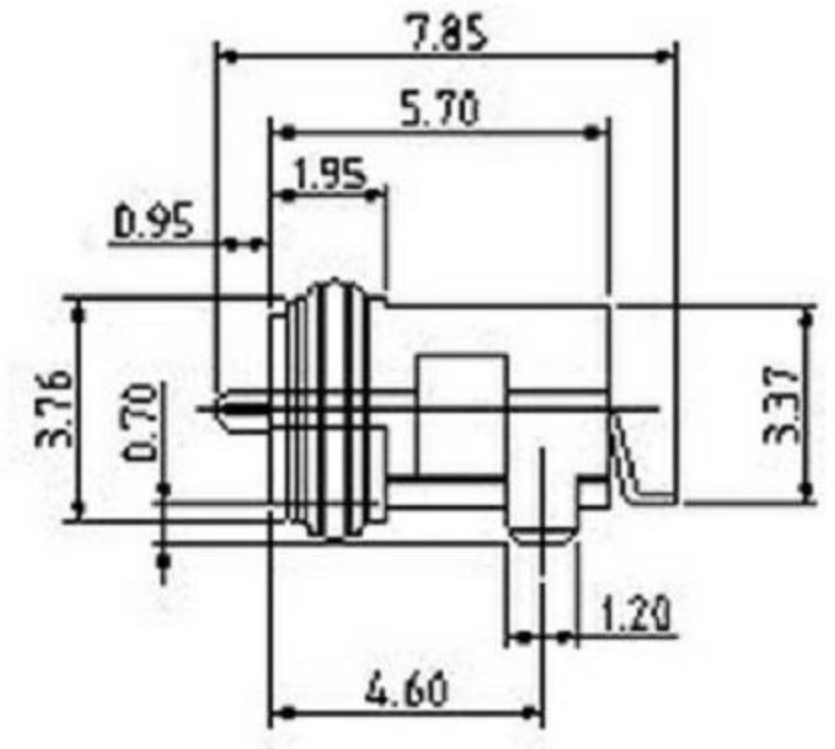

INTERFACE(FRONT VIEW)

A1	A2	A3	A4	A5	A6	A7	A8	A9	A10	A11	A12
GND			VBUS	CC1	DP1	DN1	SBU1	VBUS			GND
GND			VBUS	SBU2	DN2	DP2	CC2	VBUS			GND
B12	B11	B10	B9	B8	B7	B6	B5	B4	B3	B2	B1

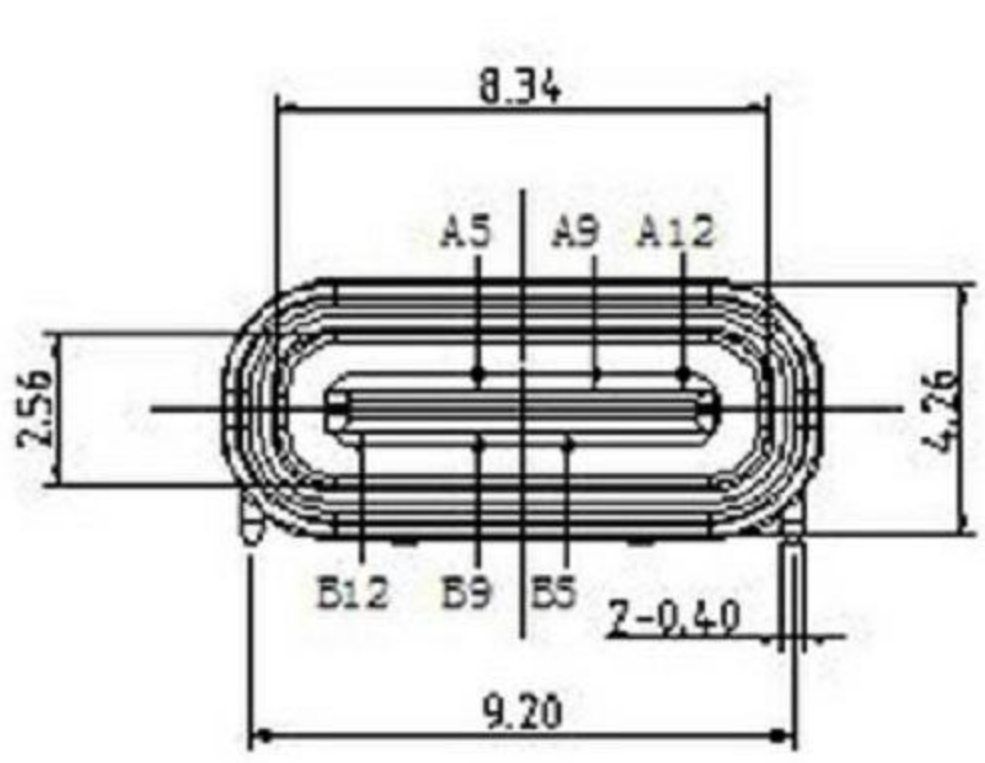
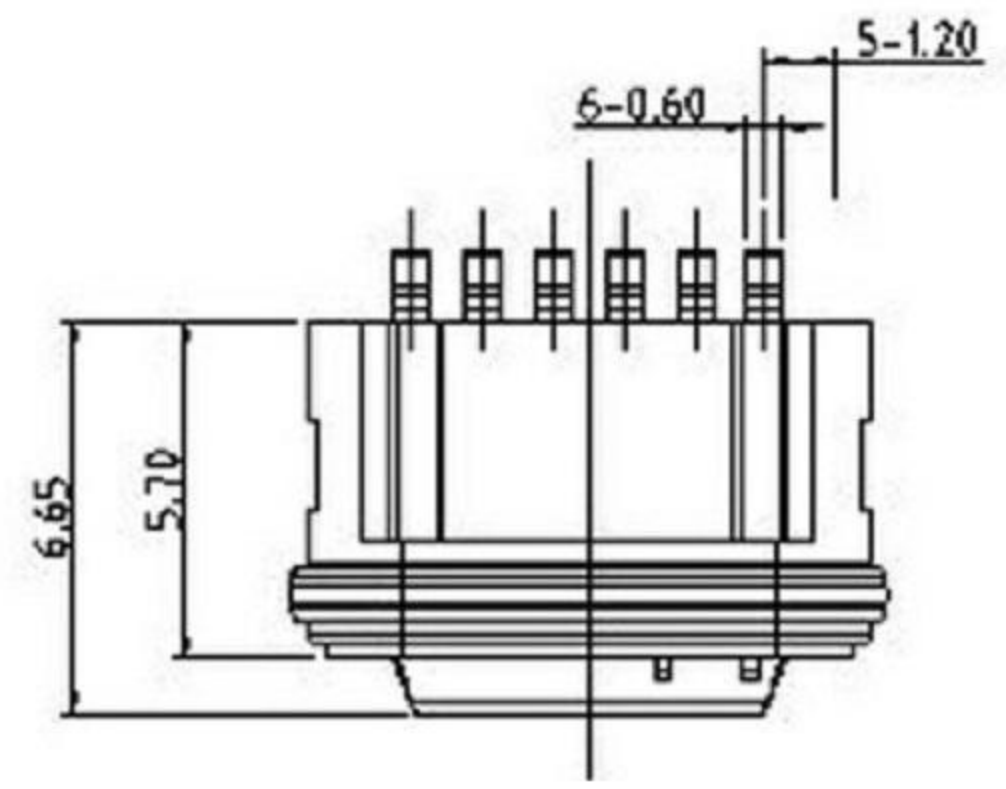
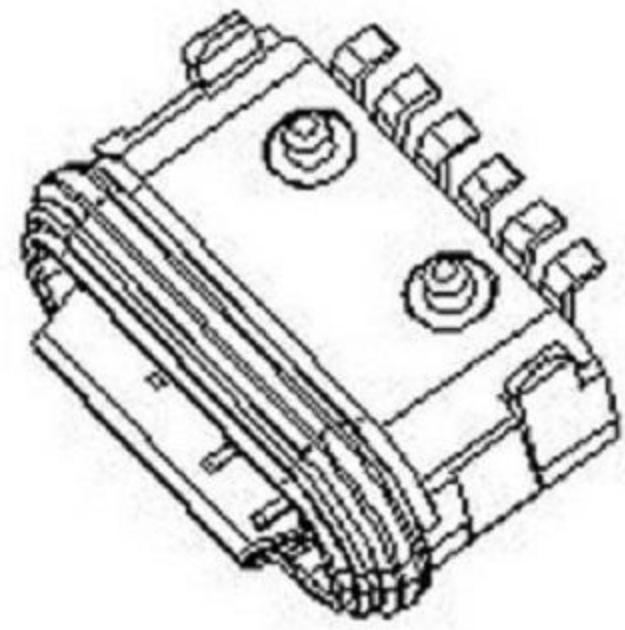

NOTES:

SPECIFICATION:

1. CURRENT RATING: 3.0A MAX
2. DIELECTRIC WITHSTAND VOLTAGE: 100VAC
3. TEMPERATURE RANGE: -30 °C ~ 85 °C
4. CONTACT RESISTANCE: 40 MILLIONHM MAX
5. INSULATION RESISTANCE: 100 MEGOHMS MIN.
6. INSERTION FORCE :8N~35N
7. UNMATING FORCE: 8N~35N
8. DURABILITY:1500 CYCLES

3	Shell	1	SUS 301 1/4H	
3	PLASTIC Shell	1	PA9T&LCP (G.F30%)	
2	Contact	4	BRASS C2680-EH Au/Ni Plating T=0.25mm	
1	Housing	1	PA10T (G.F30%)	
ITEM	PART NAME	Q'TY	FINISH	NOTE

X.	±0.50	X.*	± 2°	UNITS	mm
.X	±0.30	.X.*	± 1°		
.XX	±0.10	.XX.*	± 0.5°	MAT'L	/
.XXX	± 0.05				
THESE DRAWINGS AND SPECIFICATIONS ARE THE PROPERTY OF E-ZONE ELECTRONIC TECHNOLOGY CO.,LTD.AND SHALL NOT BE REPRODUCED, COPIED OR USED IN ANY MANNER WITHOUT THE PRIOR WRITTEN CONSENT OF E-ZONE ELECTRONIC TECHNOLOGY CO., LTD				FINISH	/
				Q'TY	/

廣東科斯達電子科技有限公司

PART NO.	TITLE:
	IP68
APPD: RADDM	DWG NO.:
CHKD: MARK	USB connector
DR: JANE CHOU 2019/07/11	SCALE SHEET REV.
	1/1 1/2 A2