

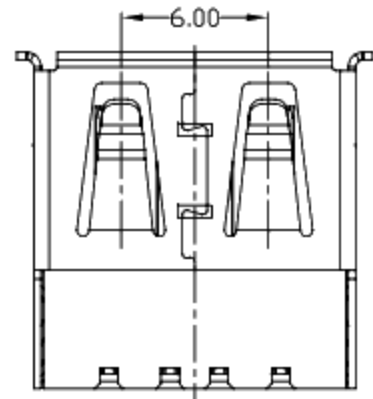

RoHS
Compliant
2002/95/EC

REV.	ECN.	NO.	APPD.

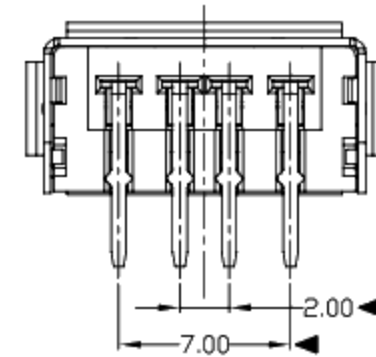
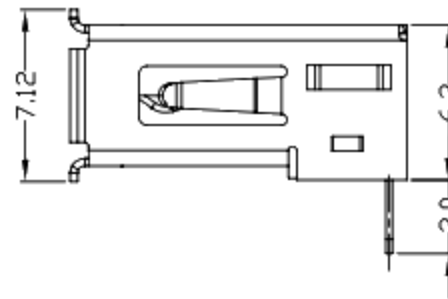
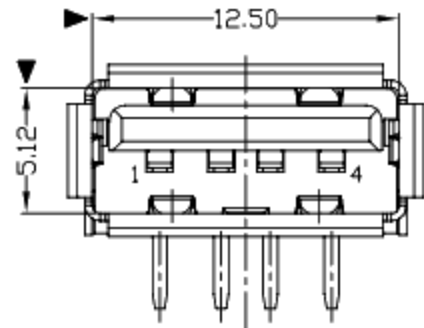
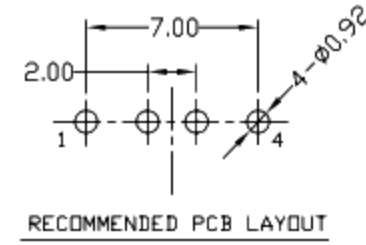
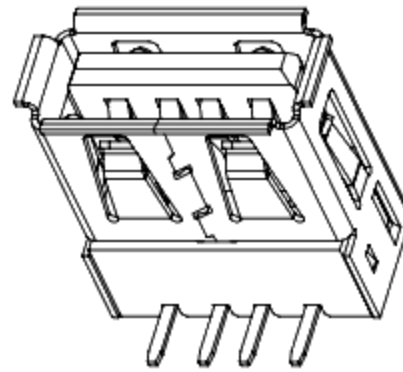
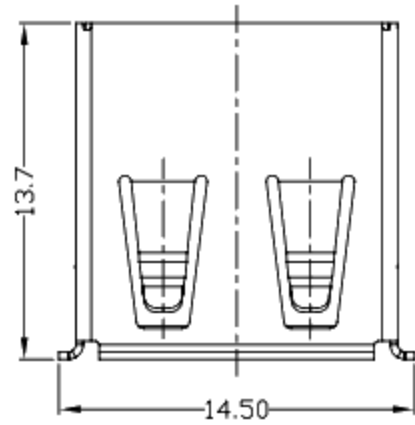

NOTES:

1. ELECTRICAL:

- 1) VOLTAGE CURRENT RATING: 2AMP, 30V AC;
- 2) INSULATION RESISTANCE: 1000MΩ, MIN;
- 3) CONTACT RESISTANCE: 30mΩ MAX;
- 4) WITHSTANDING VOLTAGE: 500V AC;
- 5) OPERATING TEMPERATURE: -55°C TO +85°C.

2. Mechanical:

- 1) Mating Force: 35N MAX
- 2) Unmating Force: 10N MIN.

3. NOTE: 1. DIMENSIONS MARKED "▼" TO BE CHECKED BY Q.C & IPQC.

4. PART NO.

1: Au 10"
6: Au 30U"

W: WHITE
B: BLACK

1: PBT
2: PA6T
3: PA9T
4: LCP

Bill of materials:

NO	PARTS	MATERIAL	QTY	FINISHING	UNITS	mm	廣東科斯達電子科技有限公司					
3	HOUSING	PBT	1	UL94V-0	X. ±0.35	X.* ±2*	TITLE:	USB AP DIP90度 一型无脚无后盖				
2	SHELL	COPPER ALLOY	1	PLATED NICKEL	.X ±0.3	.X* ±1*	MAT'L	PART NO.:				
1	TERMINAL	COPPER ALLOY	4	PLATED GOLD/TIN	.XX ±0.25	.XX*	SEE NOTE	DR:	gan 2012/6/29			
					.XXX ±0.15	.XXX*	FINISH	CHKD:	gan 2012/6/29			
							SEE NOTE	APPD:	gan 2012/6/29			
							Q'TY	SCALE	SHEET	REV.	CUSTOMER	
								1:1	1/1	B	DRAWING	

THESE DRAWINGS AND SPECIFICATIONS ARE THE PROPERTY OF ACCURATE INNOVATECH INC AND SHALL NOT BE REPRODUCED, COPIED OR USED IN ANY MANNER WITHOUT THE PRIOR WRITTEN CONSENT OF ACCURATE INNOVATECH INC.

