

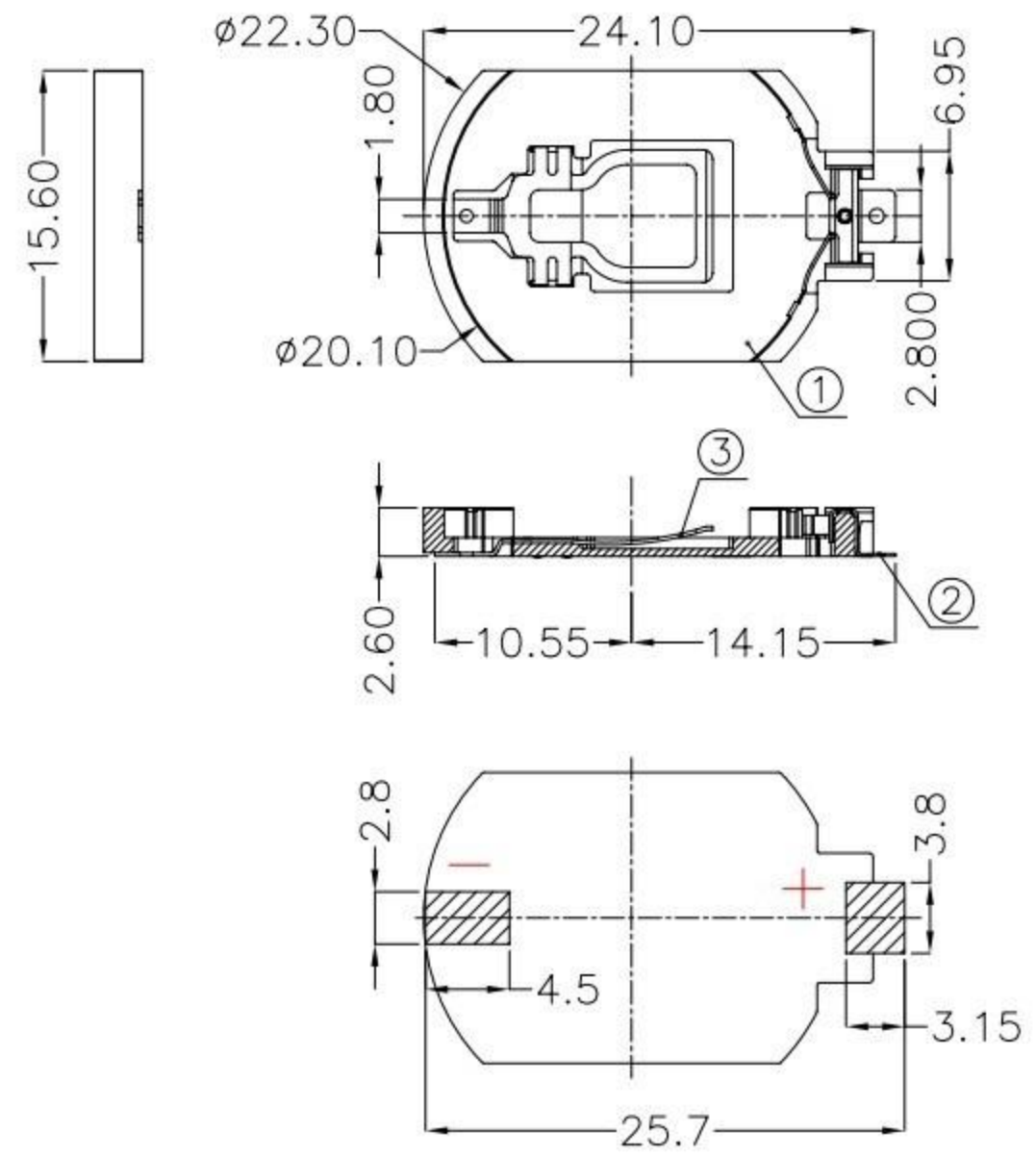

REV.	ECN NO.	REVISED	DATE



PCB Layout Diagram
Top View

NOTE:

- 1.MATERIAL:
 a.HOUSING:PPA
 b.CONTACT:PHOSPHOR BRONZE
 (SURFACE PLATING: Au1u")
 SEE ORDERING INFORMATION
- 2.ELECTRIC:
 a.CONTACT RESISTANCE: 30 MILLIOHMS MAX
 b.INSULATION RESISTANCE: 1000 MEGA OHMS MIN
 c.DIELECTNIC VOLTAGE: 500V AC ONE SEC LEVEL
 d.OPERATING TEMPERATURE: -25°C~ +85°C

ORDERING INFORMATION

电池座系列

SMT 180° TYPE

PLATING:
 A-Au1U"
 J-Ni100U"~120U"
 K-Sn100U"~120U"

MATERIAL:
 1A-PBT BLACK
 1B-PA66 BLACK
 2A-PPA BROWN
 2B-PPA BLACK
 3A-PPS BROWN
 3B-PPS BLACK
 4A-LCP WHITE
 4B-LCP BLACK

UNLESS OTHERWISE SPECIFIED TOLERANCES		廣東科斯達電子科技有限公司			
DECIMALS: X :±0.30 X.X :±0.25 X.XX :±0.20 X.XXX :±0.10	ANGLES: X :±1° X.X :±0.5°	DSND	DATE	2017-07-15	TITLE:
WEIGHT: 0.66g		CHKD	DATE	2017-07-15	PART NO.:
SHEET 1 OF 1		APVD	DATE	2017-07-15	
SCALE: 2:1		SIZE: A4	VIEW:	DRAW NO.	
UNIT: mm		REV.: A/0	OBJECT: MY	DRAW NO.	

NO.	PART NAME	Q'TY	MATERIAL	PLATING & COLOR
3	TERMINAL(-)	1	PHOSPHOR BRONZE, T=0.20mm	Gold Plating and Ni Under-Plating
2	TERMINAL(+)	1	PHOSPHOR BRONZE, T=0.15mm	Gold Plating and Ni Under-Plating
1	HOUSING	1	PPA	BROWN