

RECOMMENDED PCB LAYOUT  
TOP VIEW TOLERANCE  $\pm 0.05$ mm

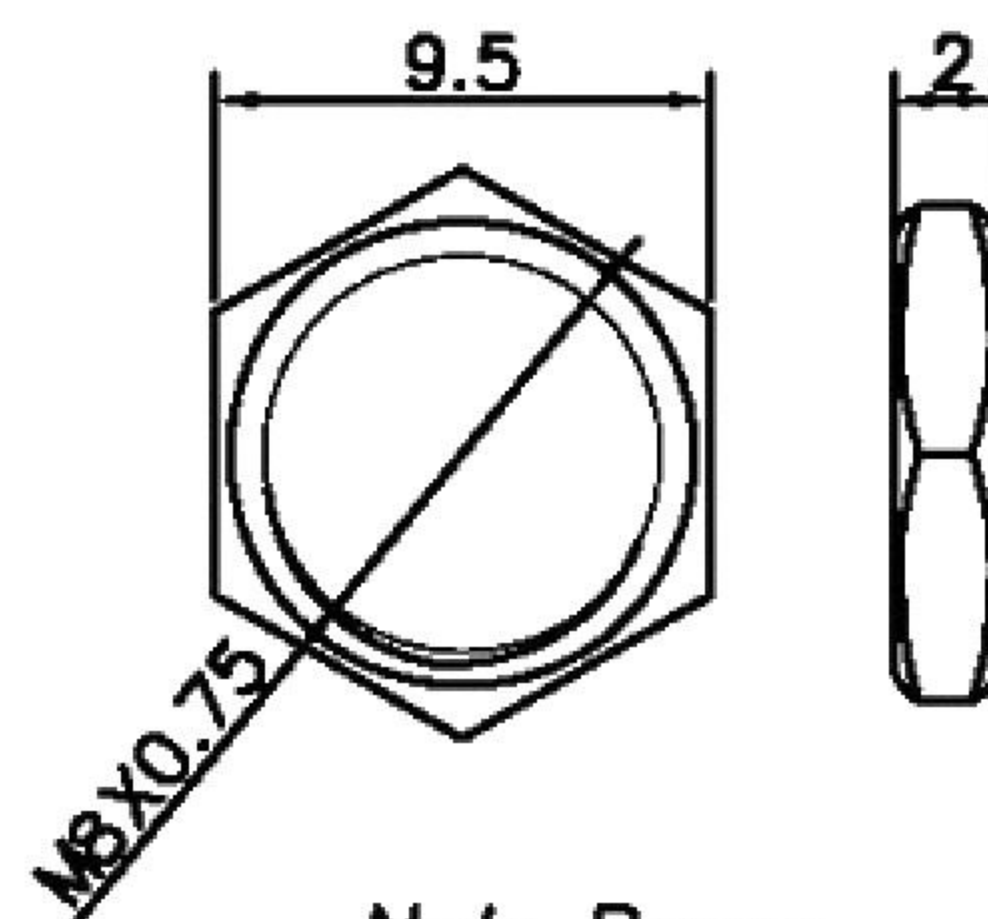

Nut: Brass

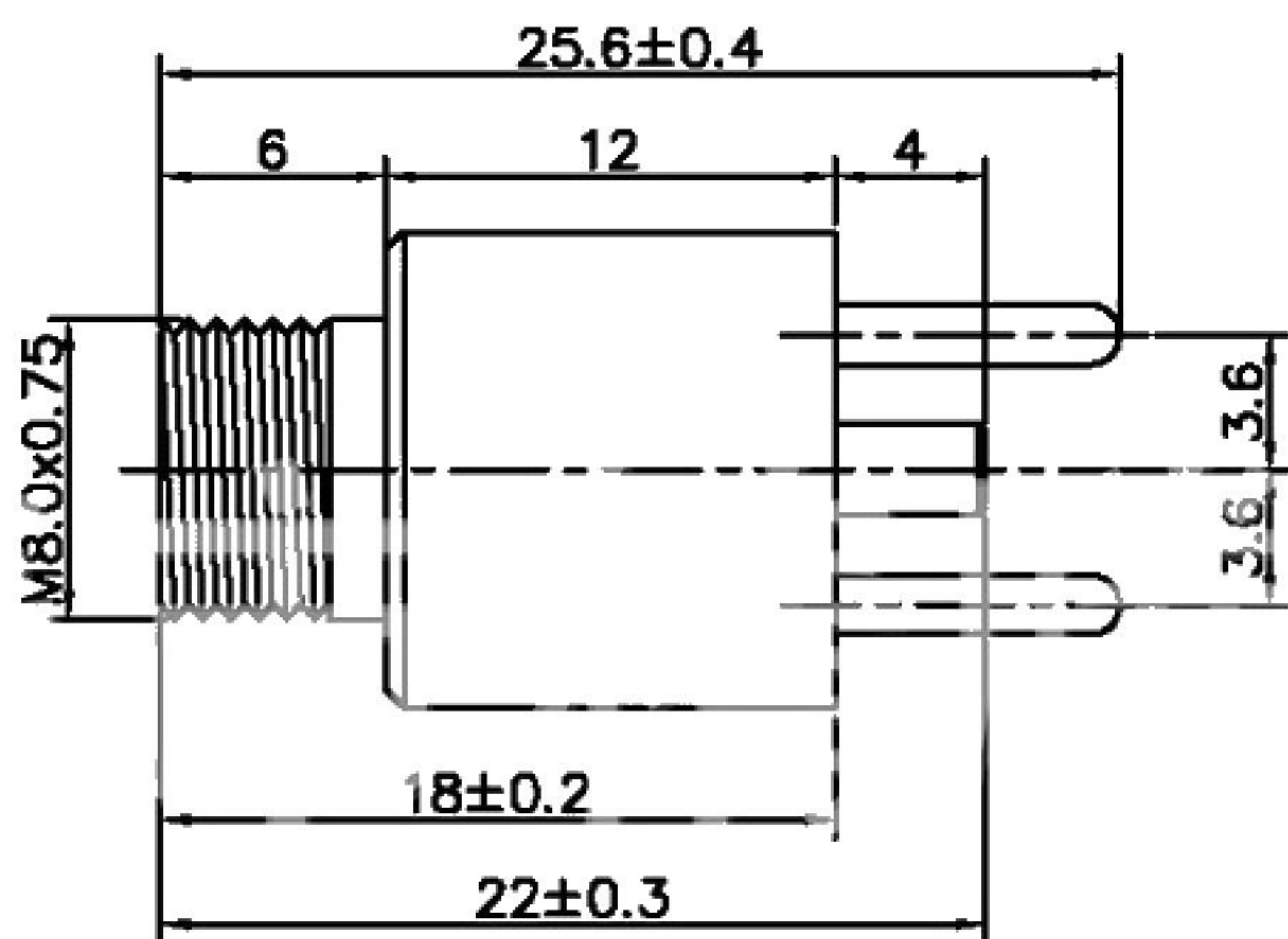
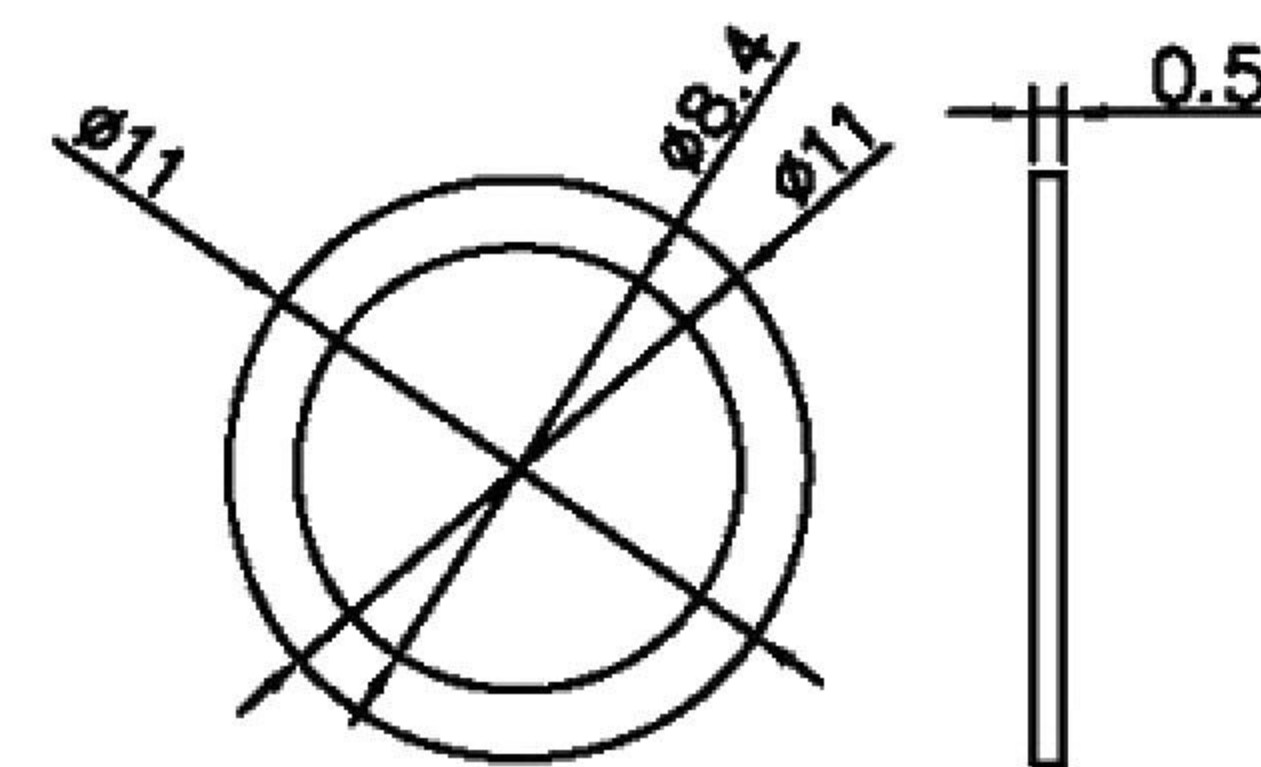

Washer: Spcc Ni Plated

|            |             |           |      |         |          |                        |               |               |  |      |  |            |                              |       |          |
|------------|-------------|-----------|------|---------|----------|------------------------|---------------|---------------|--|------|--|------------|------------------------------|-------|----------|
|            |             |           |      |         |          | ANGLAR                 | $\pm 5^\circ$ | DSND          |  | DATE |  | SCALE: N/A | MODEL TYPE:<br>DC POWER JACK |       |          |
| $\Delta X$ |             |           |      |         |          | X.X                    | $\pm 0.2$ mm  | DWN           |  | DATE |  | VIEW:      | PART NO.:                    |       |          |
| $\Delta X$ |             |           |      |         |          | X.XX                   | $\pm 0.1$ mm  | CHKD          |  | DATE |  | UNIT: mm   | DWG NO.:                     |       |          |
| $\Delta X$ |             |           |      |         |          | X.XXX                  | $\pm 0.05$ mm | APPD          |  | DATE |  | SIZE: A4   |                              |       |          |
| MARK       | DESCRIPTION | REVISIONS | DATE | REVISED | APPROVED | UNSPECIFIED TOLERANCES |               | 廣東科斯達電子科技有限公司 |  |      |  |            | WEIGHT                       | SHEET | REVISION |
|            |             |           |      |         |          |                        |               |               |  |      |  |            | 1.0g                         | 1/1   | A0       |