



REV.	ECN NO.	REVISED	DATE

NOTE:

- 1.MATERIAL:
a.HOUSING:LCP UL94V-0
b.CONTACT:PHOSPHOR BRONZE
(SURFACE PLATING:Sn100u"-120u")
SEE ORDERING INFORMATION
- 2.ELECTRIC:
a.CONTACT RESISTANCE: 30 MILLIOHMS MAX
b.INSULATION RESISTANCE: 1000 MEGA OHMS MIN
c.DIELECTNIC VOLTAGE: 500V AC ONE SEC LEVEL
d.OPERATING TEMPERATURE: -25°C~ +85°C

ORDERING INFORMATION

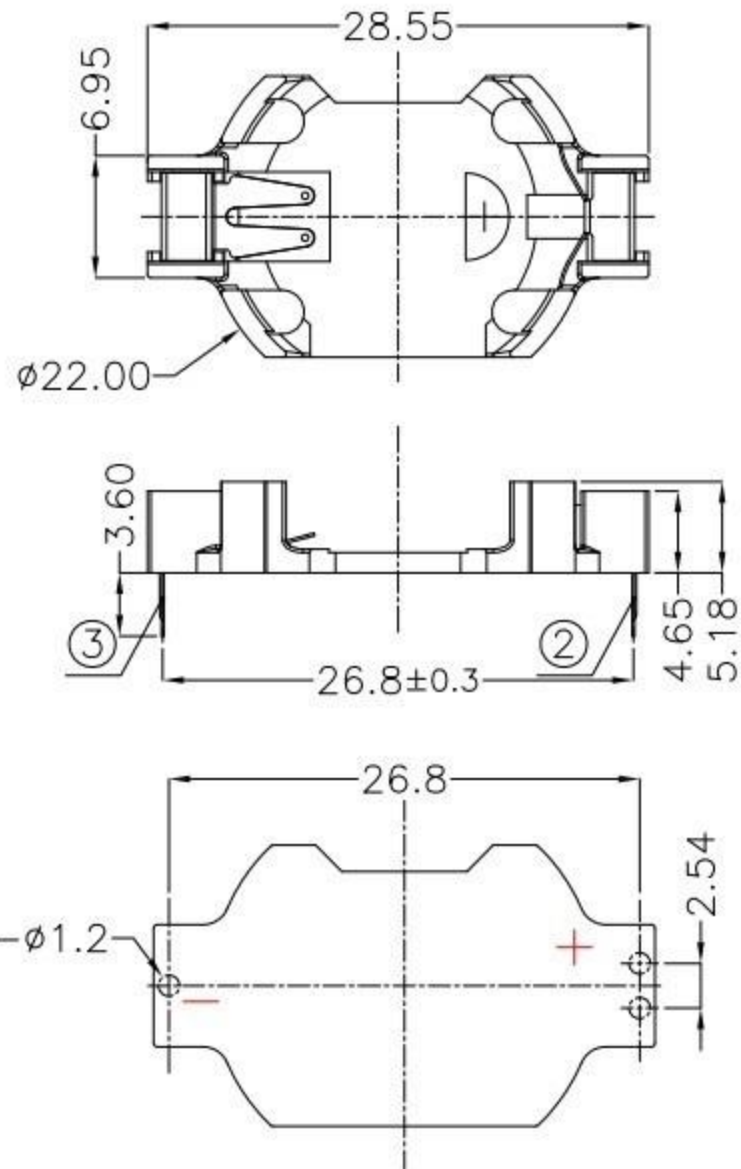
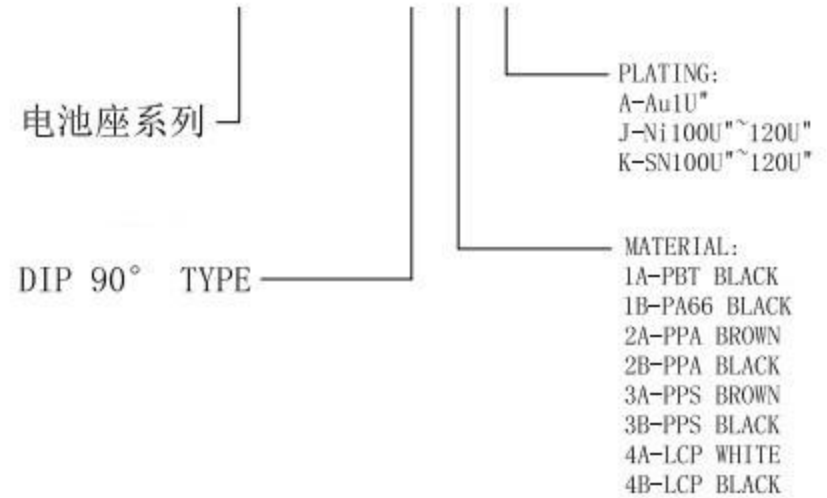

PCB Layout Diagram
Top View

UNLESS OTHERWISE SPECIFIED TOLERANCES		廣東科斯達電子科技有限公司			
DECIMALS: X :±0.30 X.X :±0.25 X.XX :±0.20 X.XXX :±0.10	ANGLES: X :±1° X.X :±0.5°	DSND	DATE	2017-07-11	TITLE:
		CHKD	DATE	2017-07-11	
		APVD	DATE	2017-07-11	PART NO.:
WEIGHT: 1.02g		SCALE: 2:1	SIZE: A4	VIEW:	
SHEET 1 OF 1		UNIT: mm	REV.: A/0	OBJECT: MY	DRAW NO.:

NO.	PART NAME	Q'TY	MATERIAL	PLATING & COLOR
3	TERMINAL(-)	1	PHOSPHOR BRONZE, T=0.20mm	Sn Plating
2	TERMINAL(+)	1	PHOSPHOR BRONZE, T=0.20mm	Sn Plating
1	HOUSING	1	LCP	WHITE