



REV.	ECN NO.	REVISED	DATE

1.MATERIAL:

- a.HOUSING:PBT UL94V-0
- b.CONTACT:PHOSPHOR BRONZE  
(SURFACE PLATING:Sn100u"-120u")

SEE ORDERING INFORMATION

2.ELECTRIC:

- a.CONTACT RESISTANCE: 30 MILLIOHMS MAX
- b.INSULATION RESISTANCE: 1000 MEGA OHMS MIN
- c.DIELECTNIC VOLTAGE: 500V AC ONE SEC LEVEL
- d.OPERATING TEMPERATURE: -25°C~ +85°C

ORDERING INFORMATION

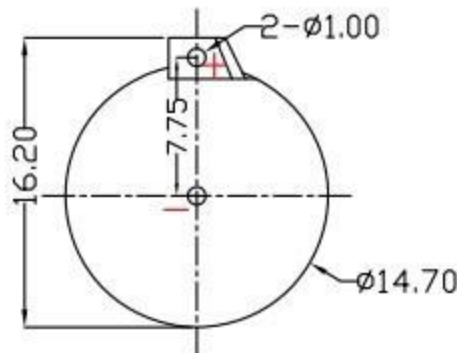
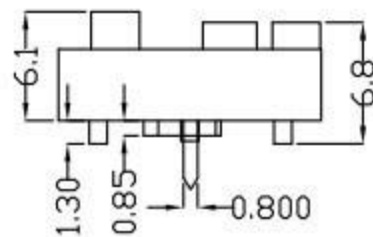
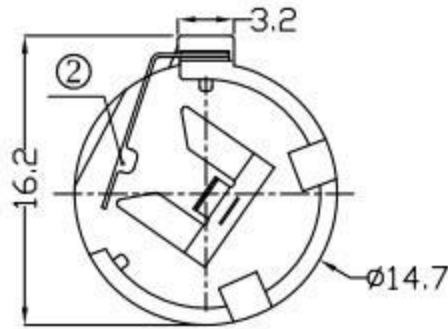
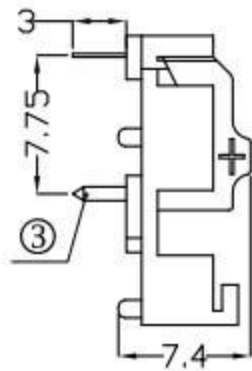

PCB Layout Diagram  
Top View

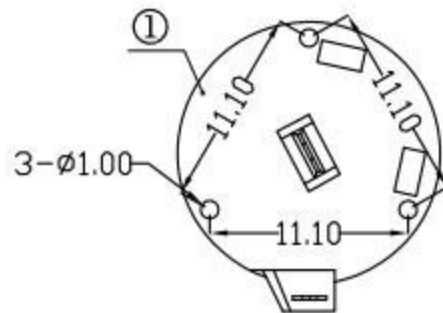

电池座系列

DIP 90° TYPE

PLATING:  
A-Au1U"  
J-Ni100U"~120U"  
K-Sn100U"~120U"  
M-Si3U"~Ni10U"

MATERIAL:  
1A-PBT BLACK  
1B-PA66 BLACK  
2A-PPA BROWN  
2B-PPA BLACK  
3A-PPS BROWN  
3B-PPS BLACK  
4A-LCP WHITE  
4B-LCP BLACK

3	TERMINAL(-)	1	PHOSPHOR BRONZE, T=0.20mm	Sn plating
2	TERMINAL(+)	1	PHOSPHOR BRONZE, T=0.20mm	Sn plating
1	HOUSING	1	PBT	BLACK
NO.	PART NAME	Q'TY	MATERIAL	PLATING & COLOR

UNLESS OTHERWISE SPECIFIED TOLERANCES				<b>廣東科斯達電子科技有限公司</b> DSND      DATE 2017-07-13      TITLE: CHKD      DATE 2017-07-13 APVD      DATE 2017-07-13      PART NO.: WEIGHT: 1.91g      SCALE: 2:1      SIZE: A4      VIEW: SHEET 1 OF 1      UNIT: mm      REV.: A/0      OBJECT: MY      DRAW NO.:			
DECIMALS:	ANGLES:						
X    :±0.30	X    :±1°						
X.X    :±0.25	X.X    :±0.5°						
X.XX    :±0.20							
X.XXX    :±0.10							