

REV.	ECN NO.	REVISED	DATE

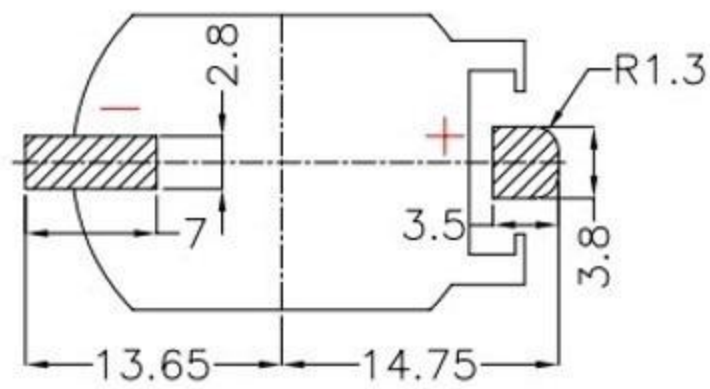
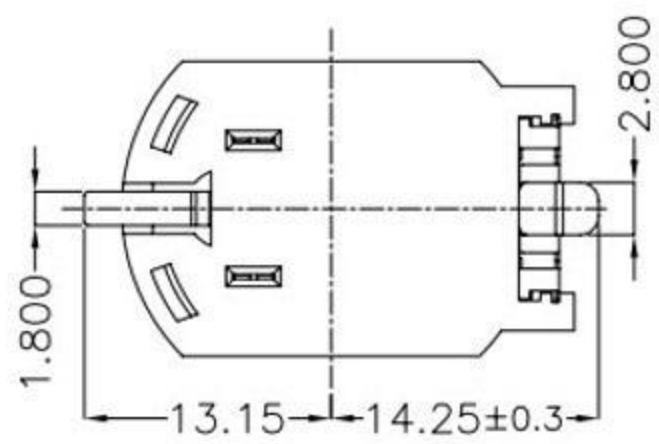
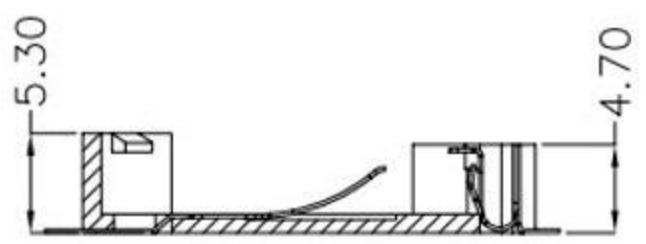
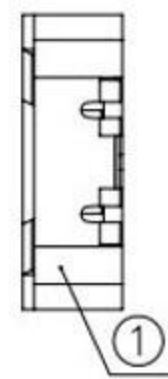
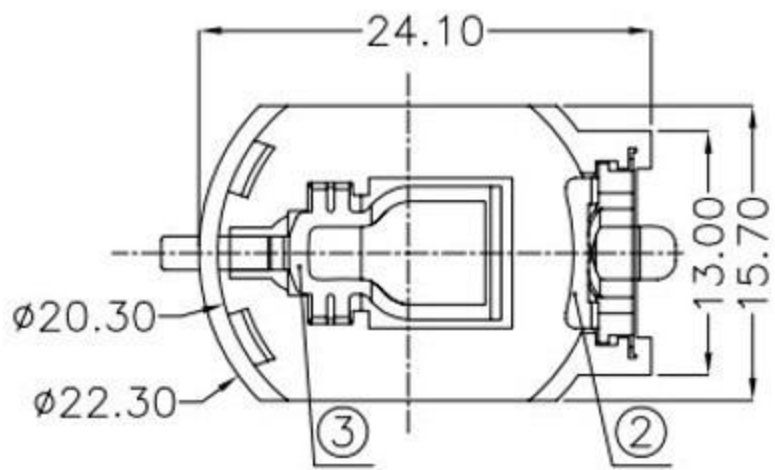

PCB Layout Diagram
Top View

NOTE:

1.MATERIAL:

- a.HOUSING:PPA
- b.CONTACT:PHOSPHOR BRONZE
(SURFACE PLATING: Au1u")

SEE ORDERING INFORMATION

2.ELECTRIC:

- a.CONTACT RESISTANCE: 30 MILLIOHMS MAX
- b.INSULATION RESISTANCE: 1000 MEGA OHMS MIN
- c.DIELECTNIC VOLTAGE: 500V AC ONE SEC LEVEL
- d.OPERATING TEMPERATURE: -25° C~ +85° C

ORDERING INFORMATION

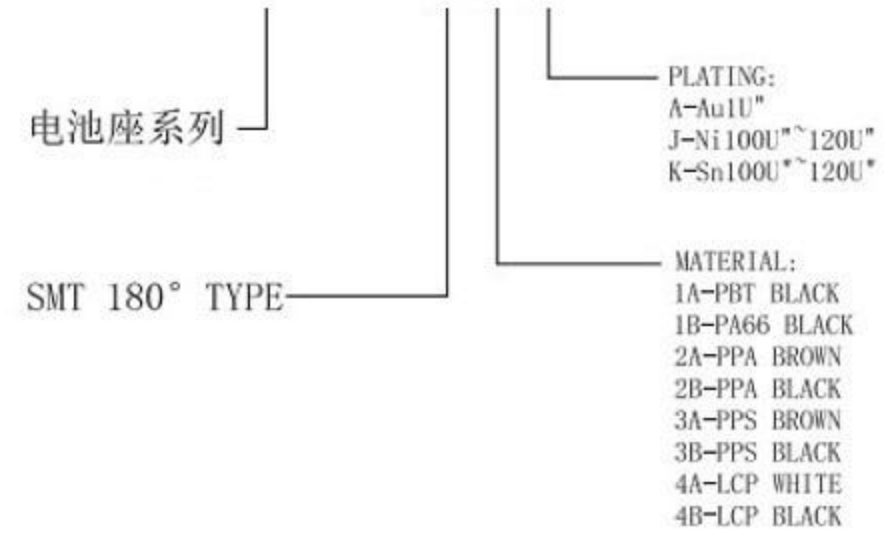

UNLESS OTHERWISE SPECIFIED TOLERANCES

廣東科斯達電子科技有限公司

DECIMALS: X :±0.30 X.X :±0.25 X.XX :±0.20 X.XXX :±0.10	ANGLES: X :±1° X.X :±0.5°	DSND	DATE	2017-06-28	TITLE:
WEIGHT: 0.86g		CHKD	DATE	2017-06-28	PART NO.:
SHEET 1 OF 1		APVD	DATE	2017-06-28	
UNIT: mm		SCALE: 2:1	SIZE: A4	VIEW:	DRAW NO.:
REV.: A/0		OBJECT: MY			

NO.	PART NAME	Q'TY	MATERIAL	PLATING & COLOR
3	TERMINAL(-)	1	PHOSPHOR BRONZE, T=0.20mm	Gold Plating and Ni Under-Plating
2	TERMINAL(+)	1	PHOSPHOR BRONZE, T=0.20mm	Gold Plating and Ni Under-Plating
1	HOUSING	1	PPA	BROWN