

P. C. B LAYOUT TOP VIEW

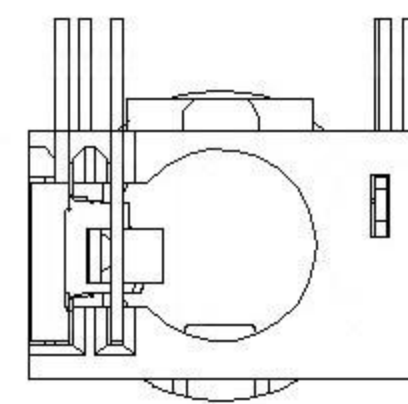
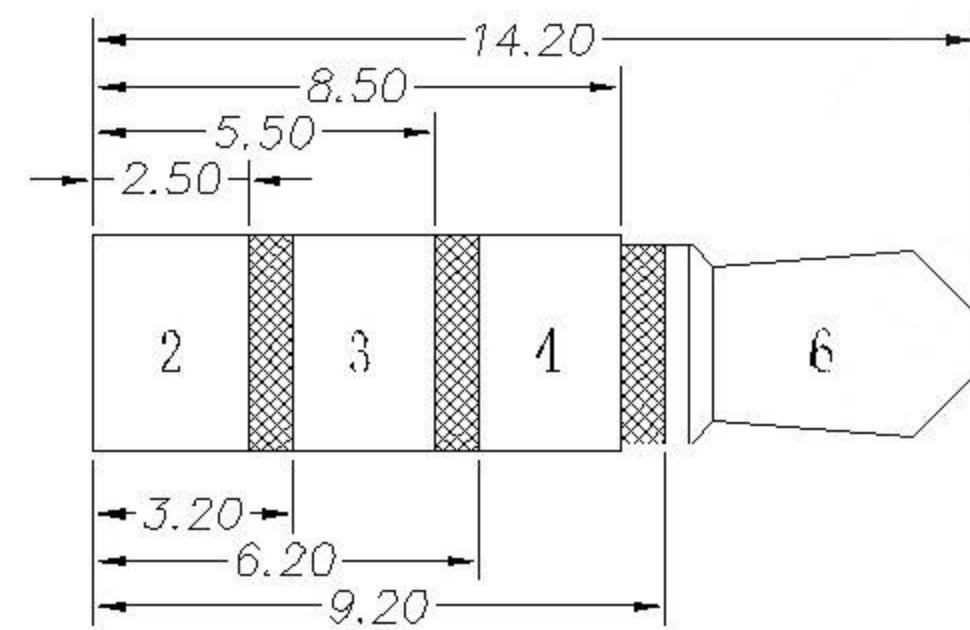

	MATERIAL	PLATING
terminal 2	Phosphor Bronze	tin
terminal 3	Phosphor Bronze	tin
terminal 4	Phosphor Bronze	tin
terminal 5	Phosphor Bronze	tin
terminal 6	Phosphor Bronze	tin
terminal 7	Phosphor Bronze	tin
plastic	Pbt	

MARK	DESCRIPTION	DATE	REVISED	APPROVED	UNSPECIFIED TOLERANCES	DSND	DATE	SCALE: N/A	MODEL TYPE: 3.5 PHONE JACK
Δx					ANGLAR ±5°	DWN	DATE	VIEW:	PART NO.:
Δx					X.X ±0.2mm	CHKD	DATE	UNIT: mm	DWG NO.:
Δx					X.XX ±0.1mm	APPD	DATE	SIZE: A4	
					X.XXX ±0.05mm	廣東科斯達電子科技有限公司			WEIGHT 1.0g
									SHEET 1/1
									REVISION A0