

受控文件

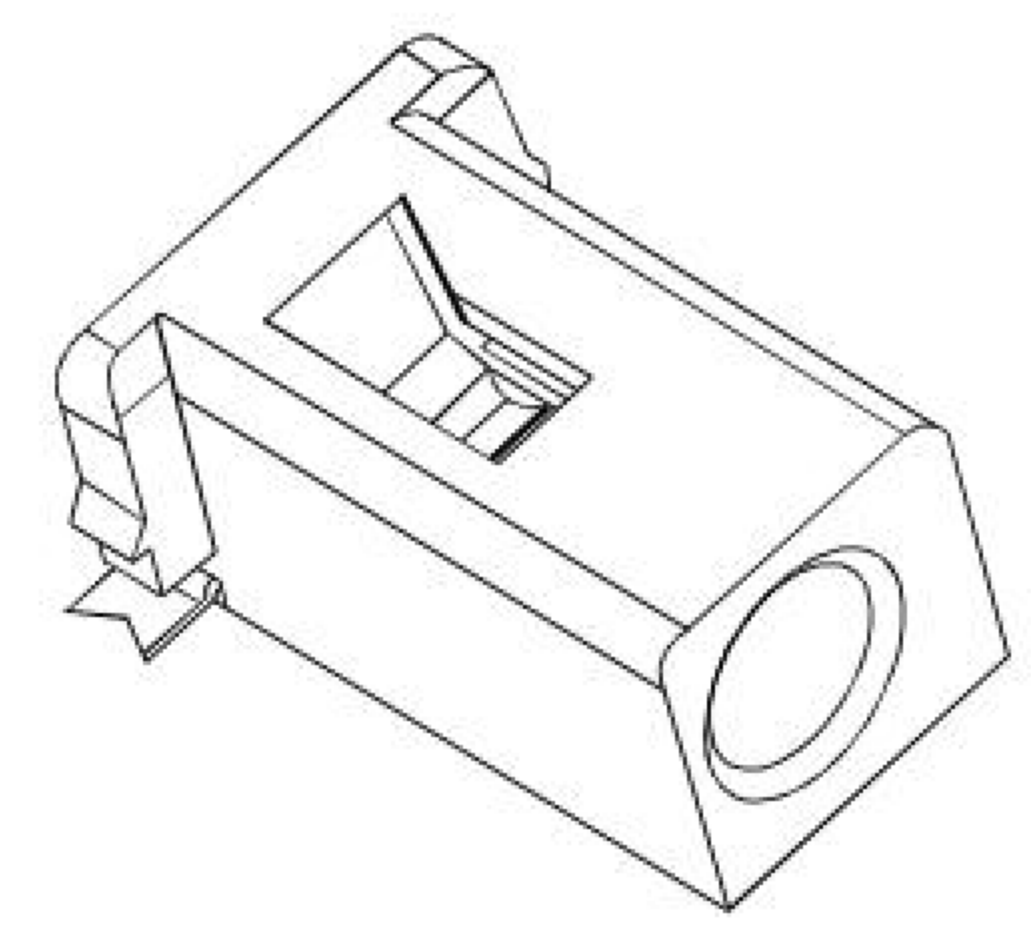
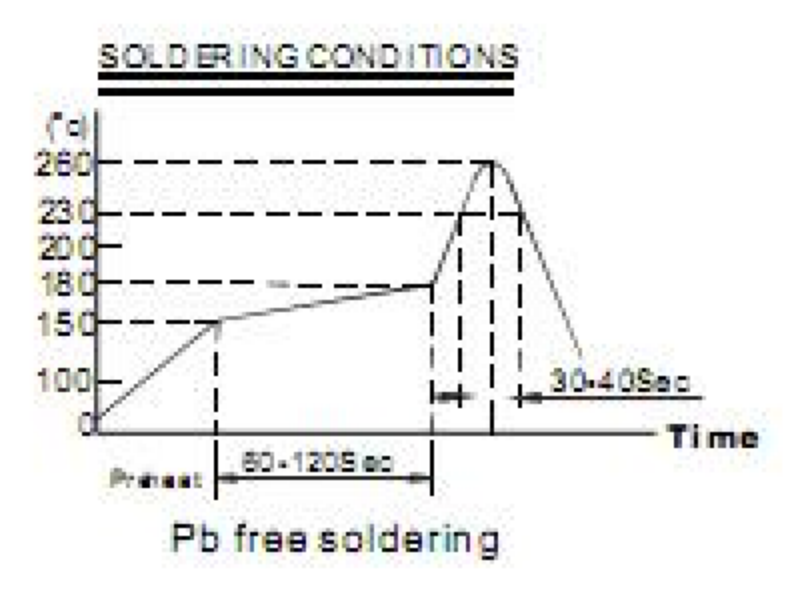
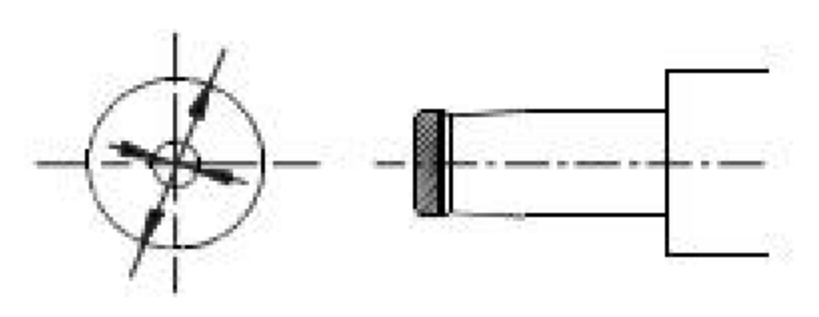
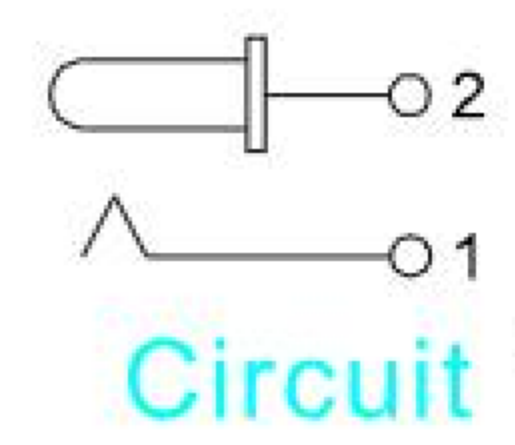
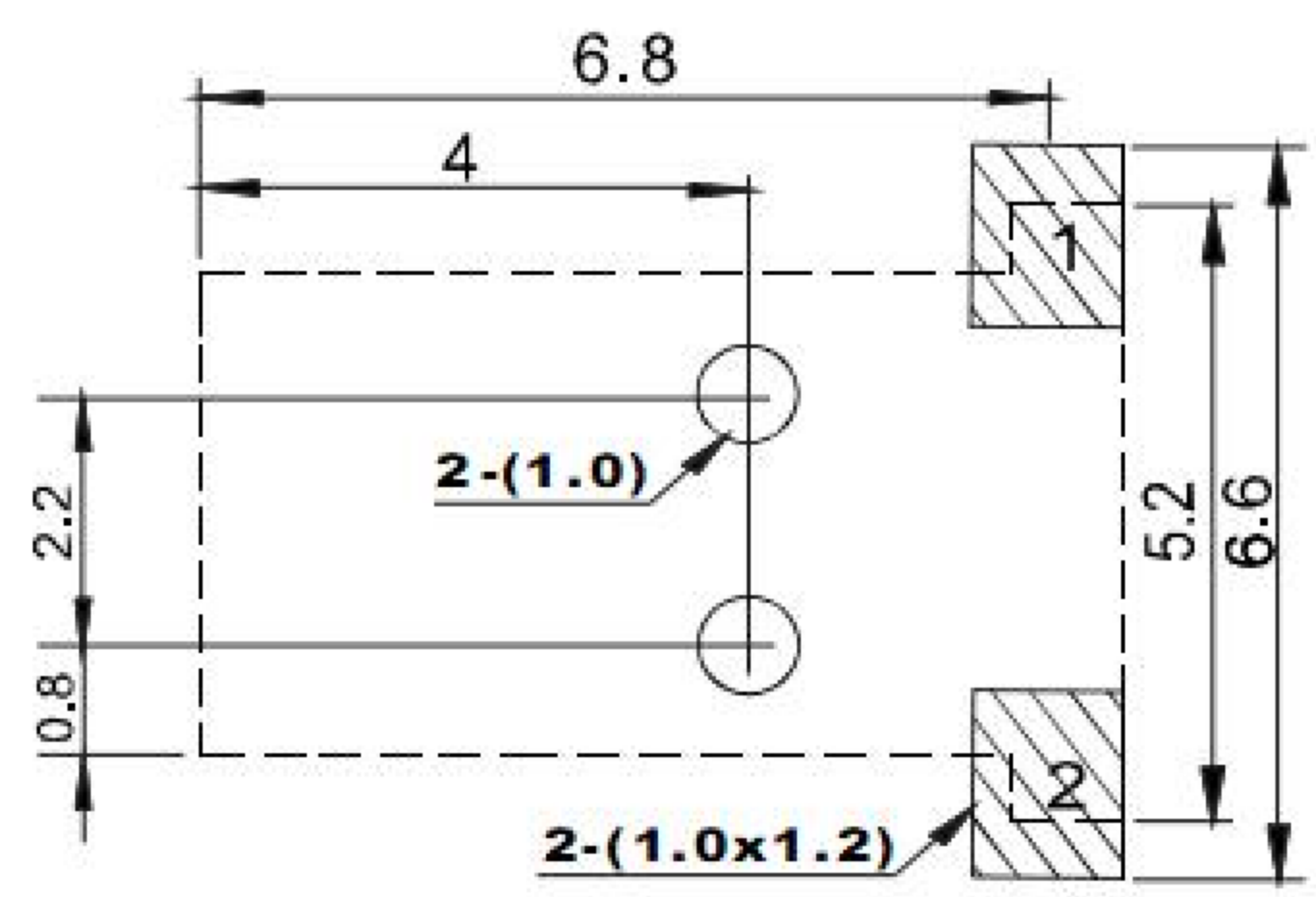
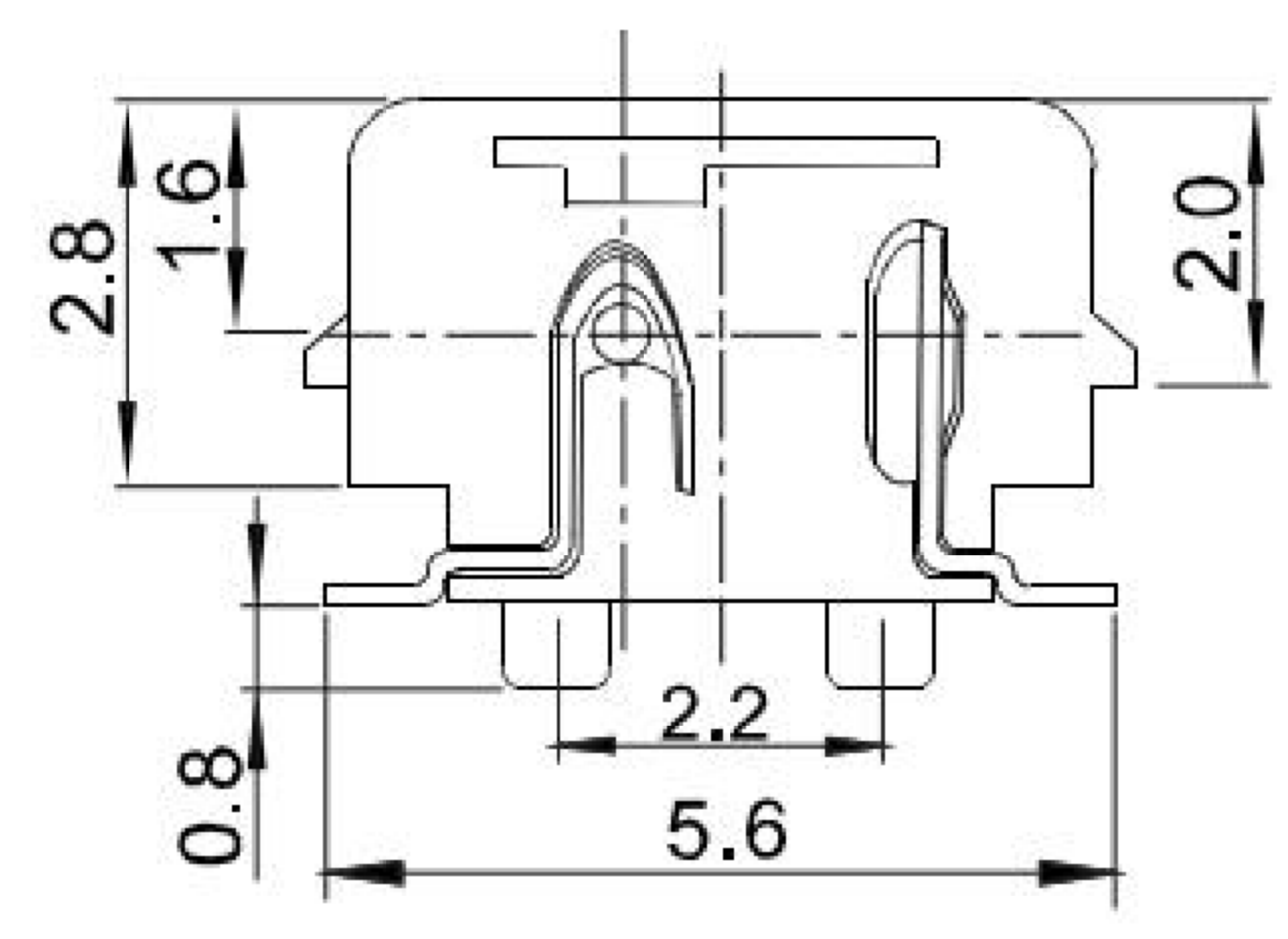
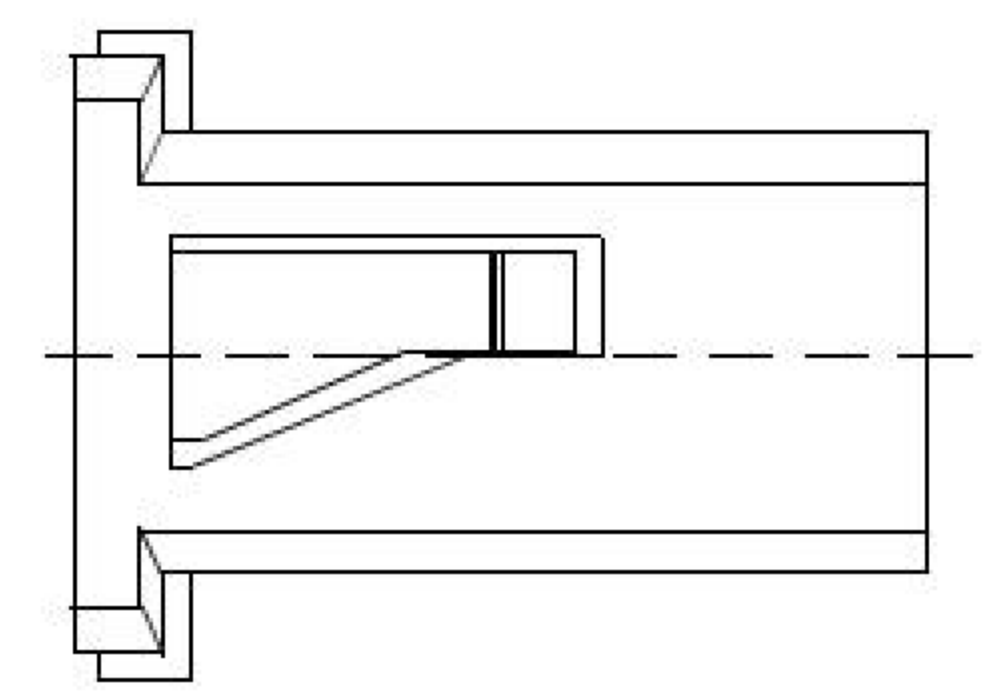
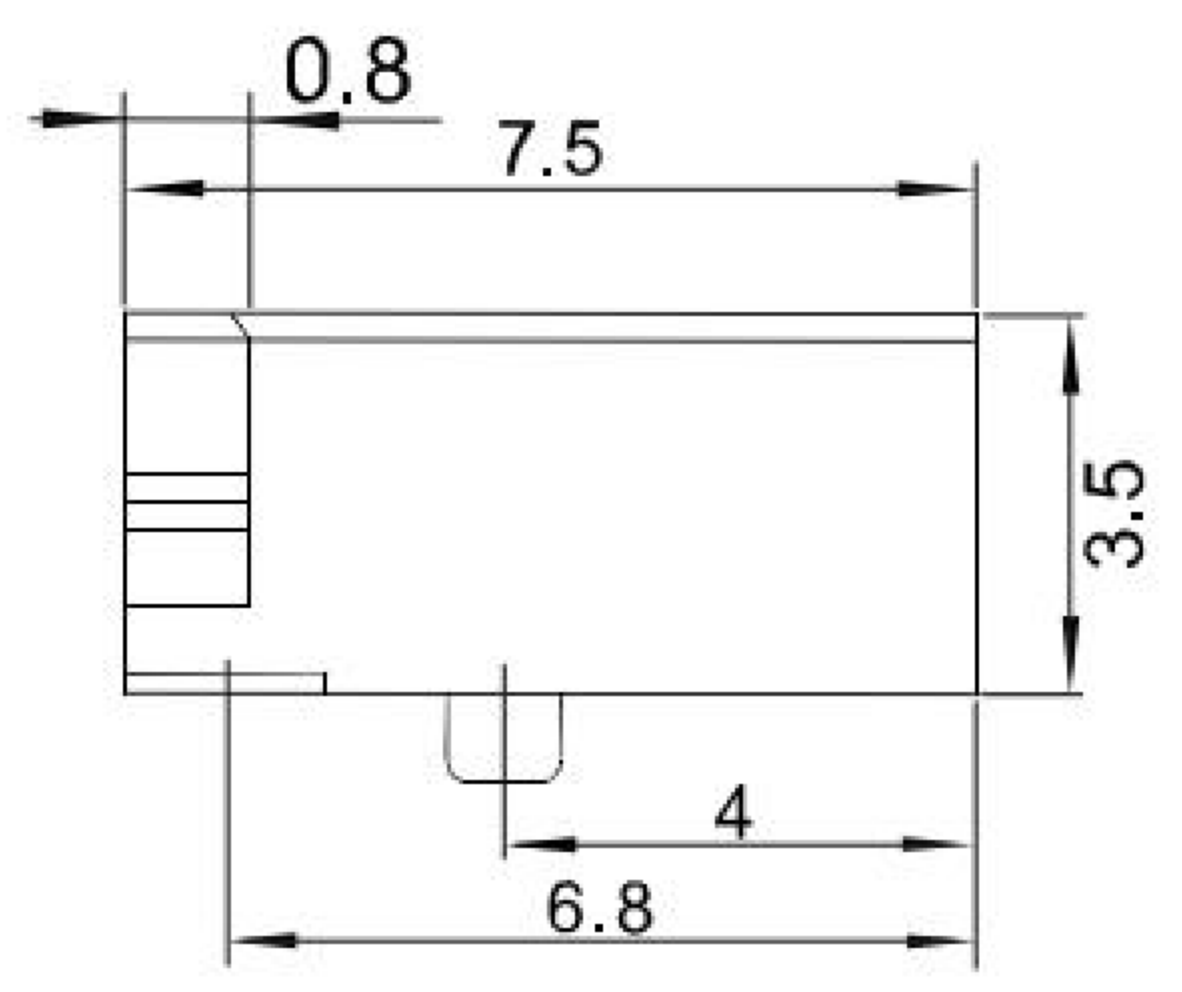
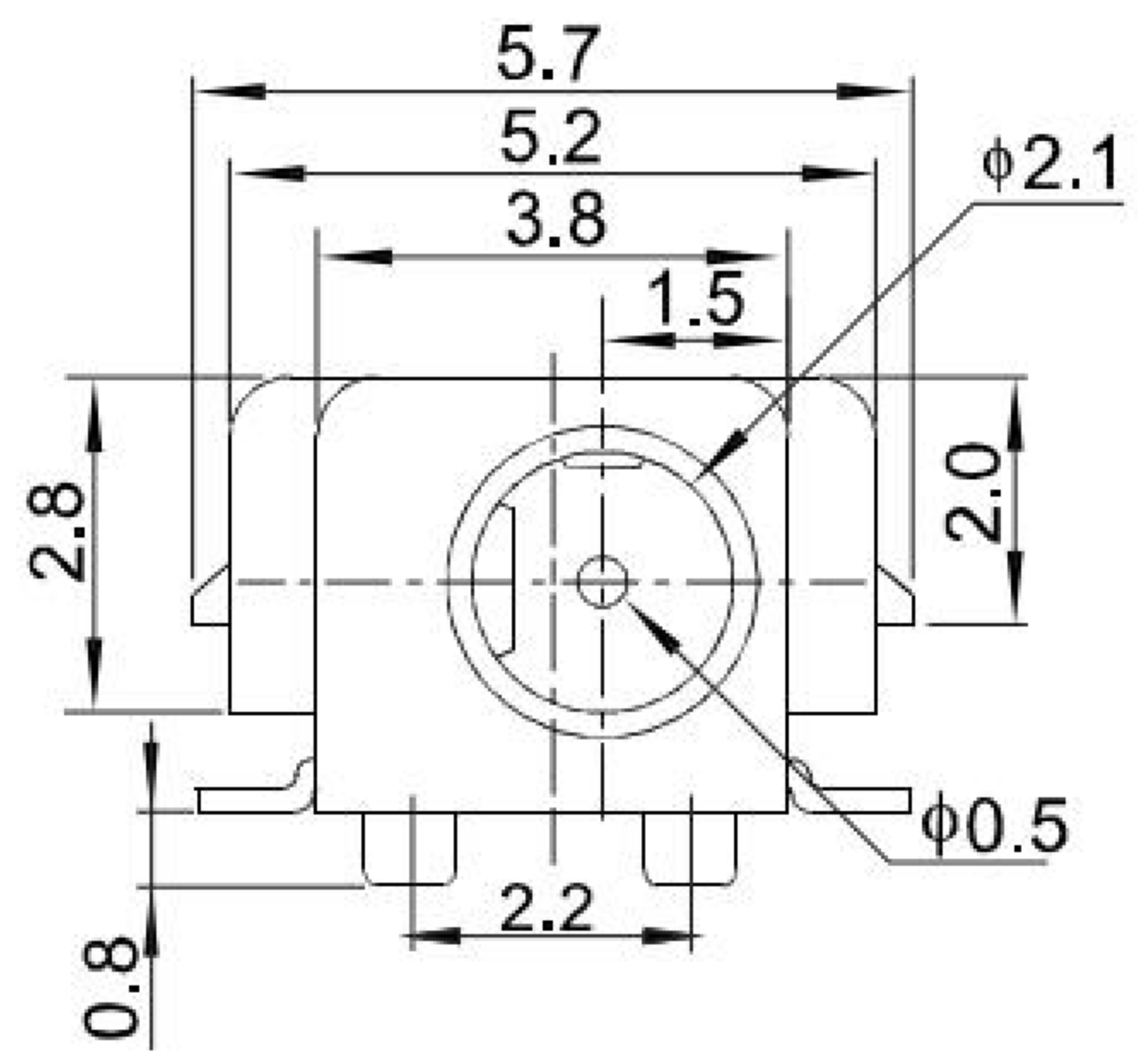

					ANGLAR	±5°	DSND		DATE		SCALE: N/A	MODEL TYPE:	DC POWER JACK		
△X					X.X	±0.2mm	DWN		DATE		VIEW:	PART NO.:			
△X					X.XX	±0.1mm	CHKD		DATE		UNIT: mm	DWG NO.:			
△X					X.XXX	±0.05mm	APPD		DATE		SIZE: A4				
MARK	DESCRIPTION	REVISIONS	DATE	REVISED	APPROVED	UNSPECIFIED TOLERANCES	廣東科斯達電子科技有限公司					WEIGHT	SHEET	REVISION	
												1.0g	1/1	A0	