

SCHEMATIC	
MODEL NO	V

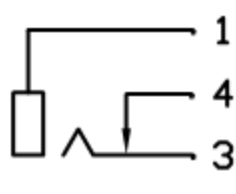
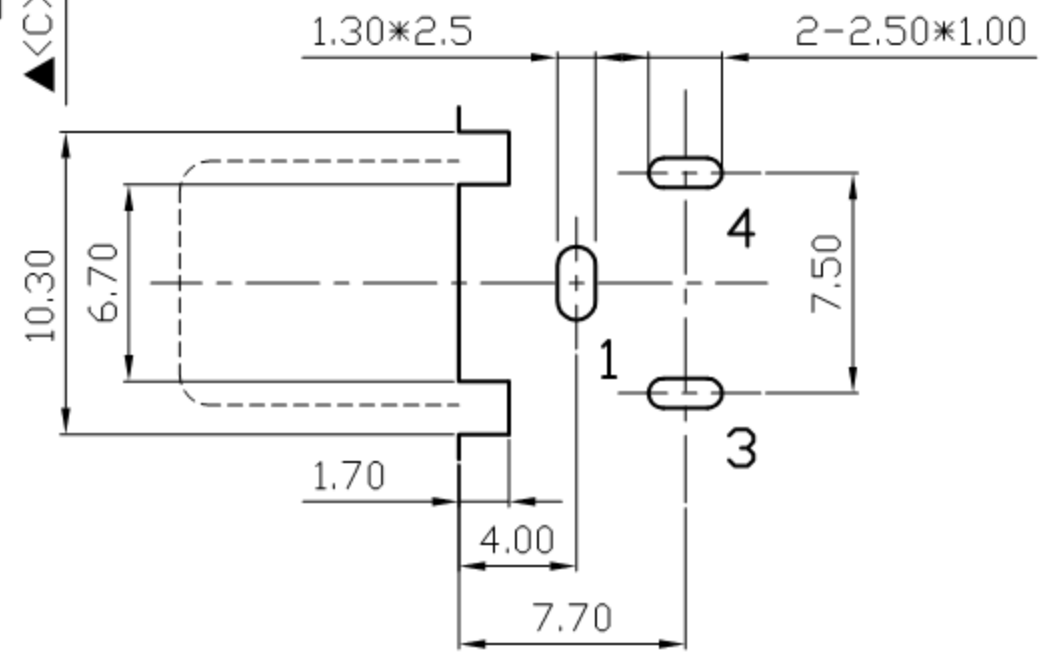
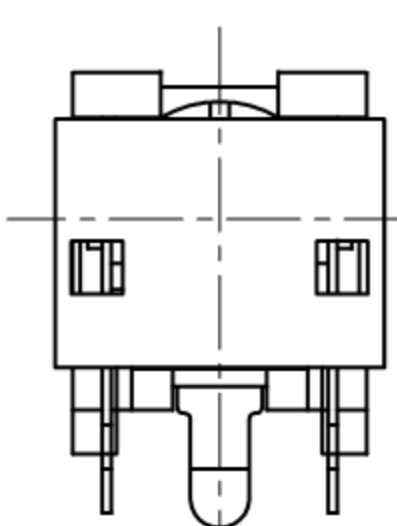
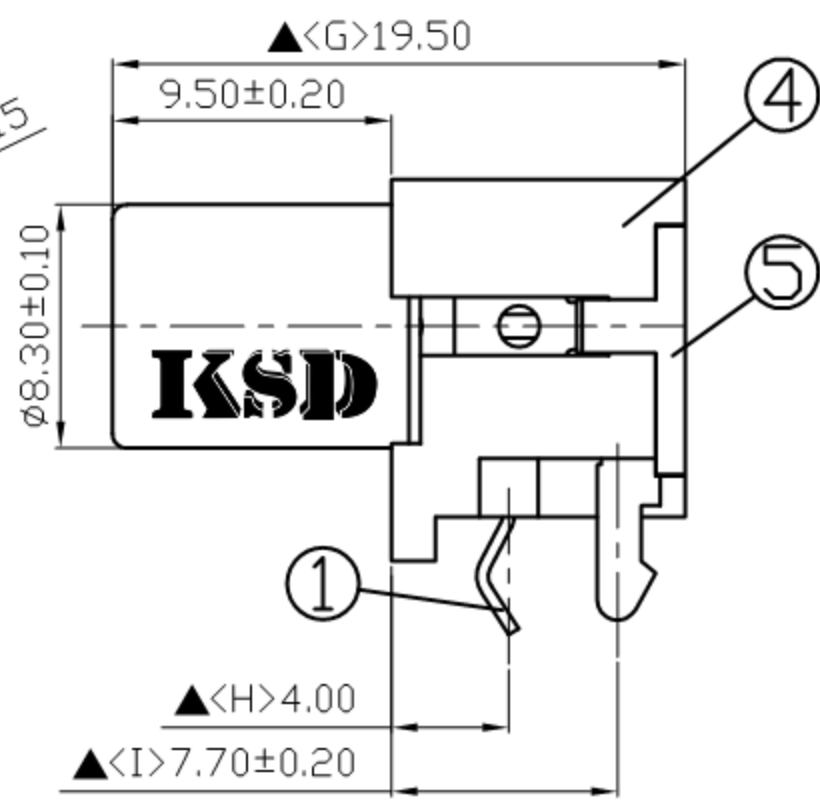
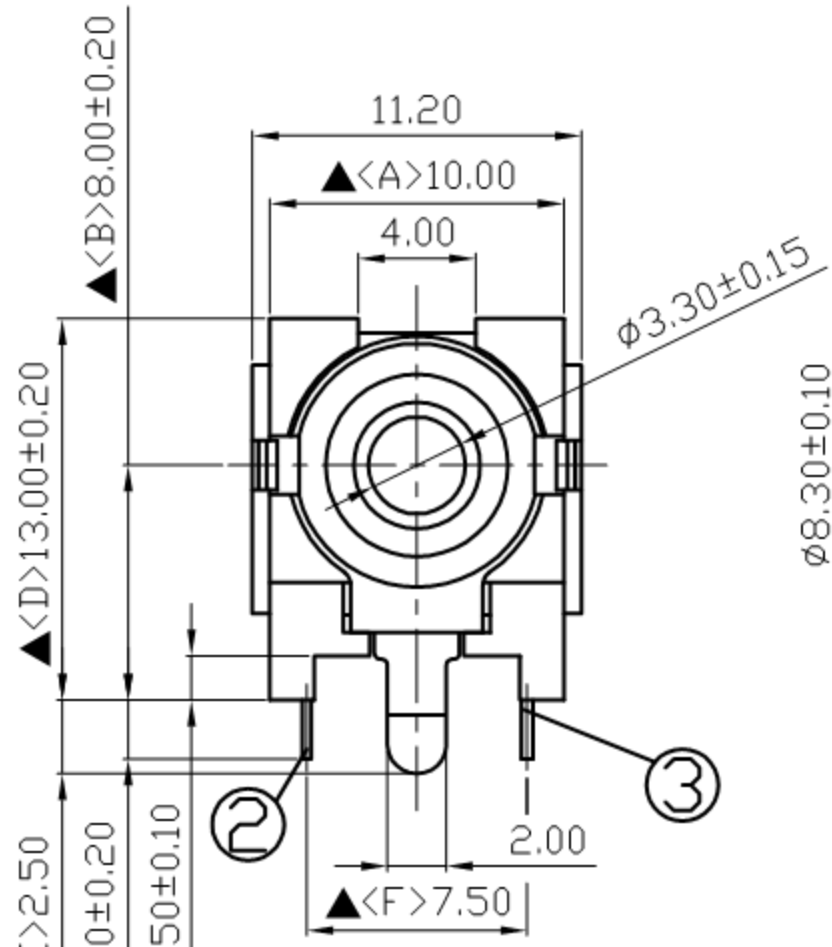
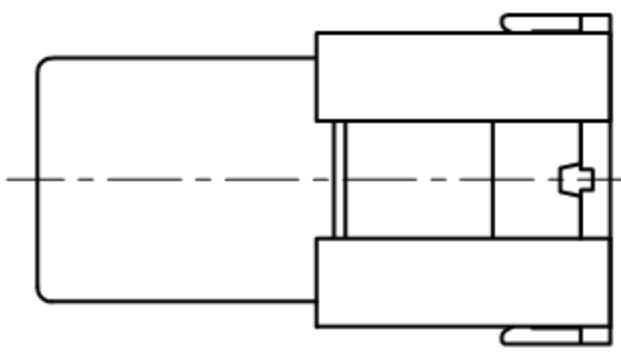

Pin Hole Layout
(Jack Bottom View)

5.	Cover	PBT	1	Black Color
4.	Housing	PBT	1	Black Color
3.	Spring Terminal	0.3T Phosphor Bronze	1	Silver Plated
2.	Break Terminal	0.3T Phosphor Bronze	1	Silver Plated
1.	Earth Terminal (Barrel)	0.4T Brass	1	Nickel Plated
NO.	Description	Material	Q'TY	Finish

RoHS
Compliant

For Reference
備供參考

SPECIFICATIONS:
 Contact Resistance : 30mΩ max
 Insulation Resistance : 100MΩ min. at DC 500V
 Dielectric Withstanding Voltage: AC 500V for one minute
 Remark: ▲: The Most Important Dimension

 广东科斯达电子科技有限公司
 GUANG DONG KE SI DA ELECTRONIC TECHNOLOGY CO., LTD.

DATE	DWN	CHKD	APVD	MANAGER
08.11.2006				

PART NAME :PIN JACK PART NUMBER:SCP625VNS10000CG VERSION:3.0

TOLERANCE :±0.3mm UNLESS OTHERWISE SPECIFIED UNIT:mm  SCALE:1/1