

SCHEMATIC	
MODEL NO	V

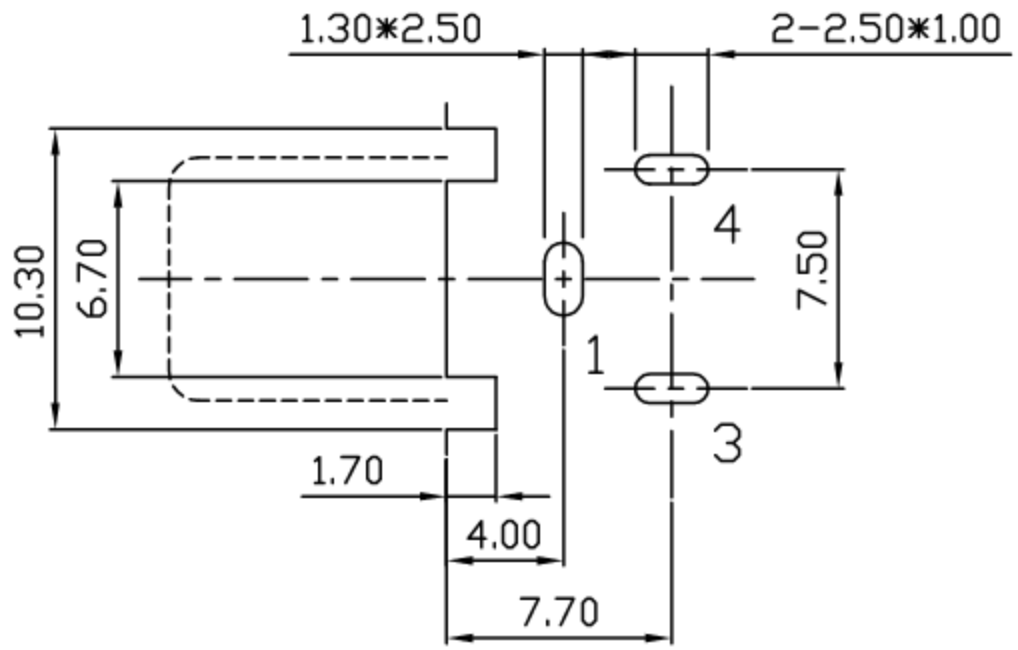
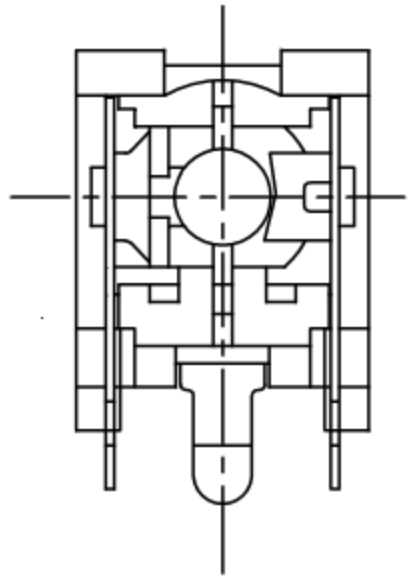
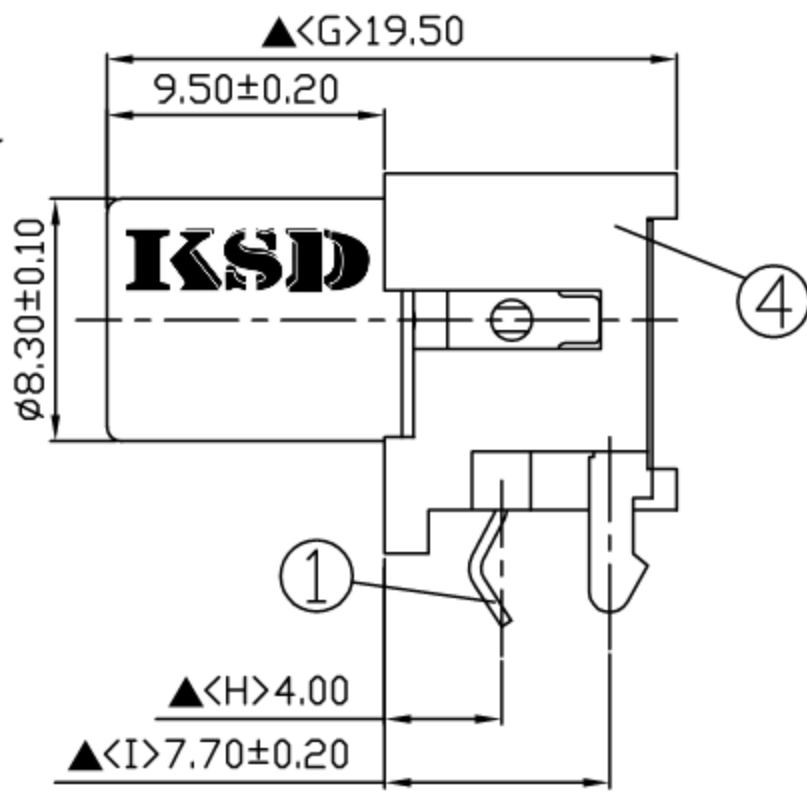
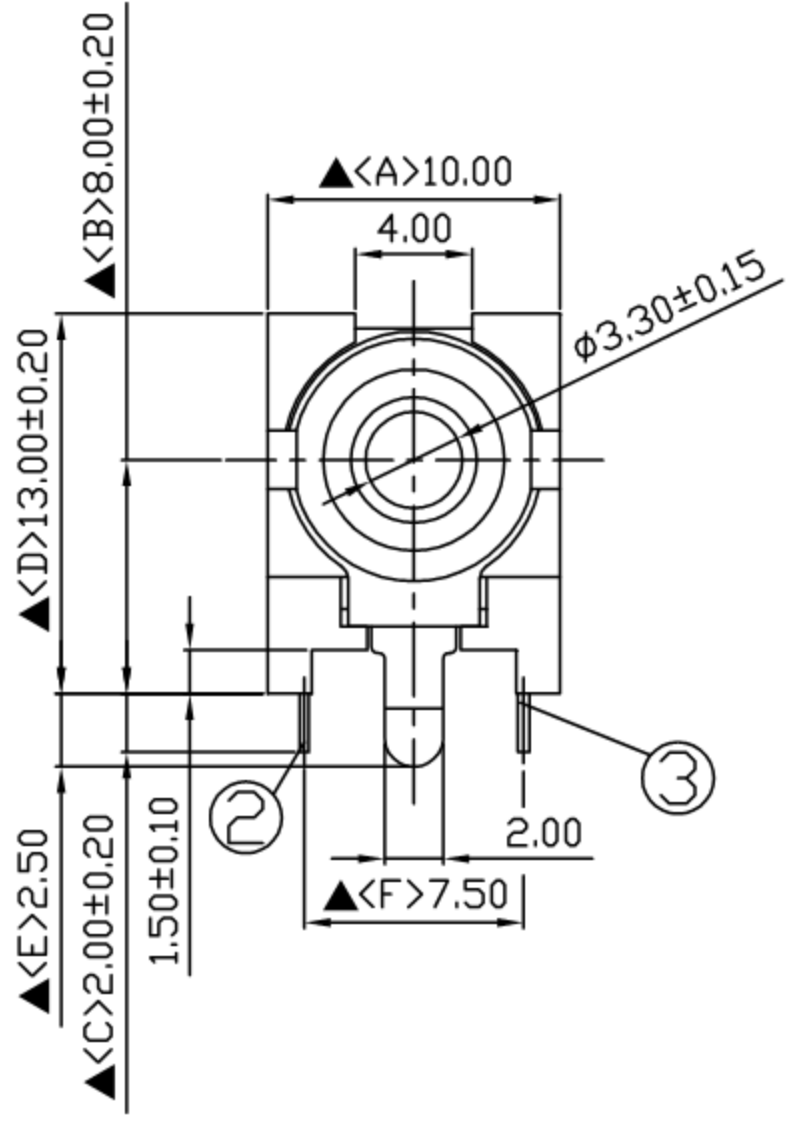
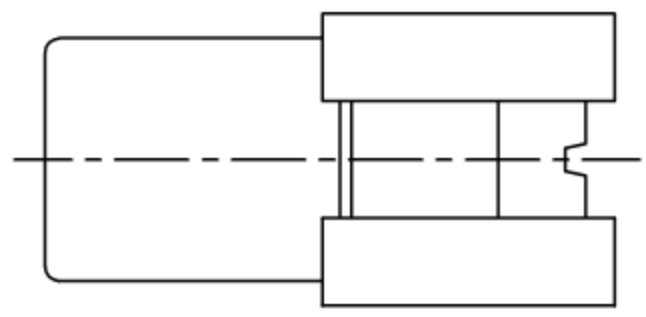

Pin Hole Layout
(Jack Bottom View)

4.	Housing	PBT	1	Black Color
3.	Spring Terminal	0.3T Phosphor Bronze	1	Silver Plated
2.	Break Terminal	0.3T Phosphor Bronze	1	Silver Plated
1.	Earth Terminal (Barrel)	0.4T Brass	1	Nickel Plated
NO.	Description	Material	Q'TY	Finish

RoHS
Compliant

For Reference
僅供參考

SPECIFICATIONS:
 Contact Resistance : 30mΩ max
 Insulation Resistance : 100MΩ min. at DC 500V
 Dielectric Withstand Voltage : AC 500V for one minute
 Remark: ▲ : The Most Important Dimension

广东科斯达电子科技有限公司 GUANG DONG KE SI DA ELECTRONIC TECHNOLOGY CO., LTD.	DATE	DWN	CHKD	APVD	MANAGER
	12.10.2005				
PART NAME :PIN JACK		PART NUMBER:SCP625VNS100000G			VERSION:3.0
TOLERANCE :±0.3mm UNLESS OTHERWISE SPECIFIED				UNIT:mm	SCALE:1/1