

螺母配件

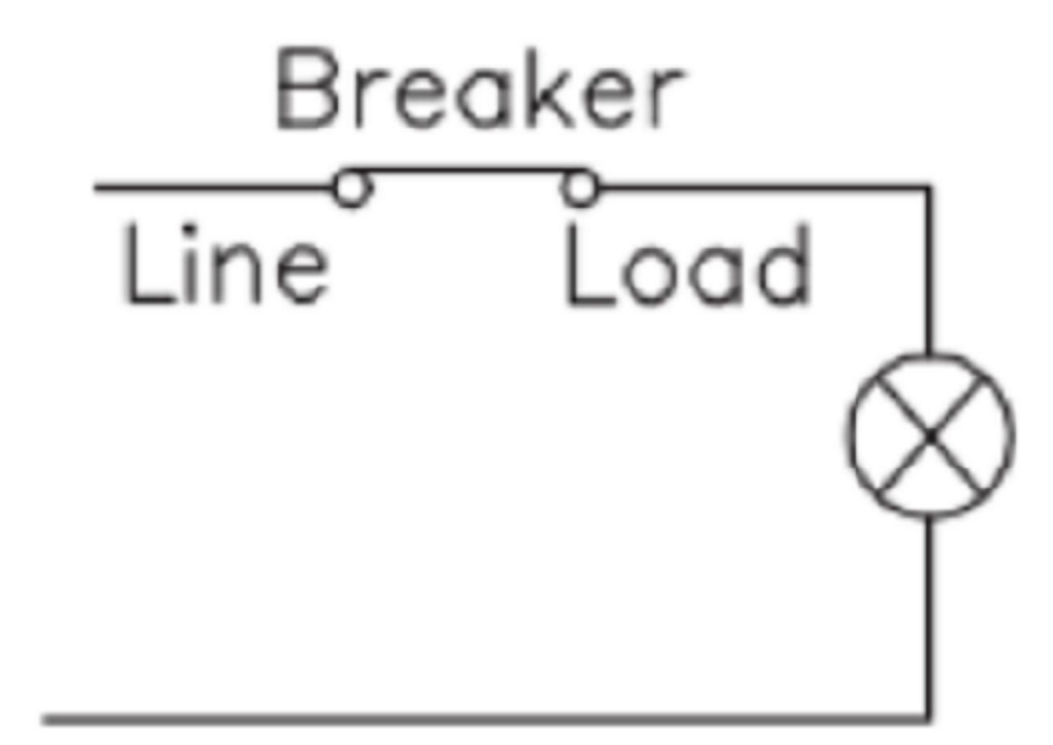

Circuit of Breaker

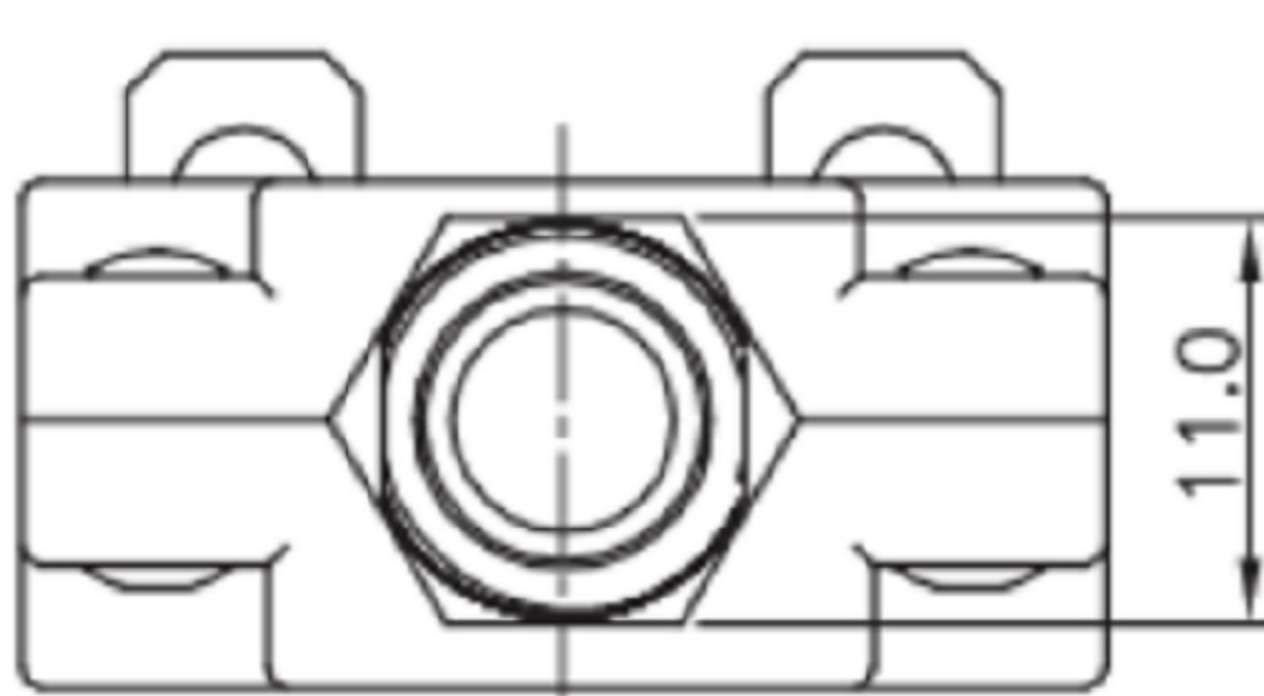
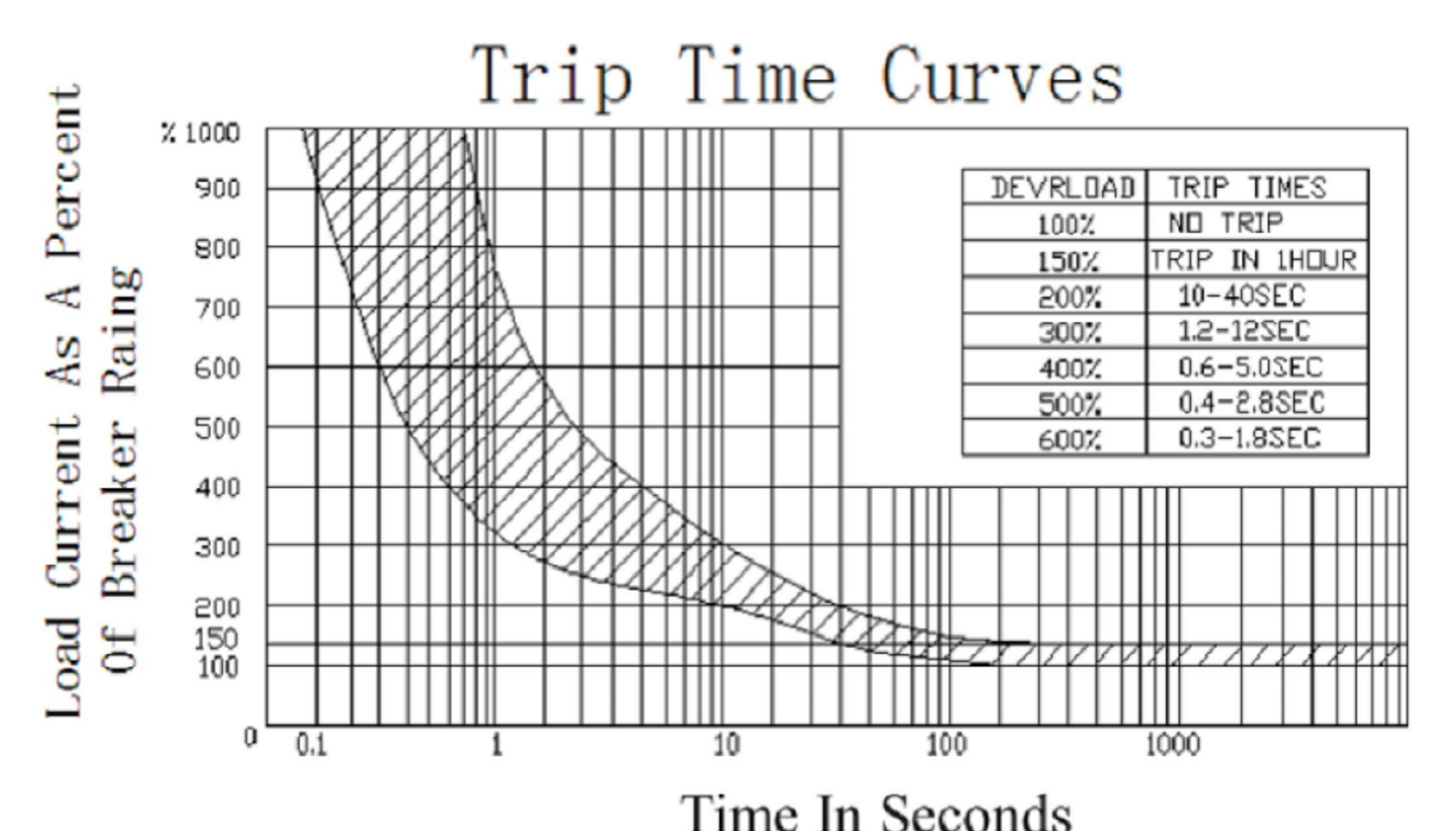
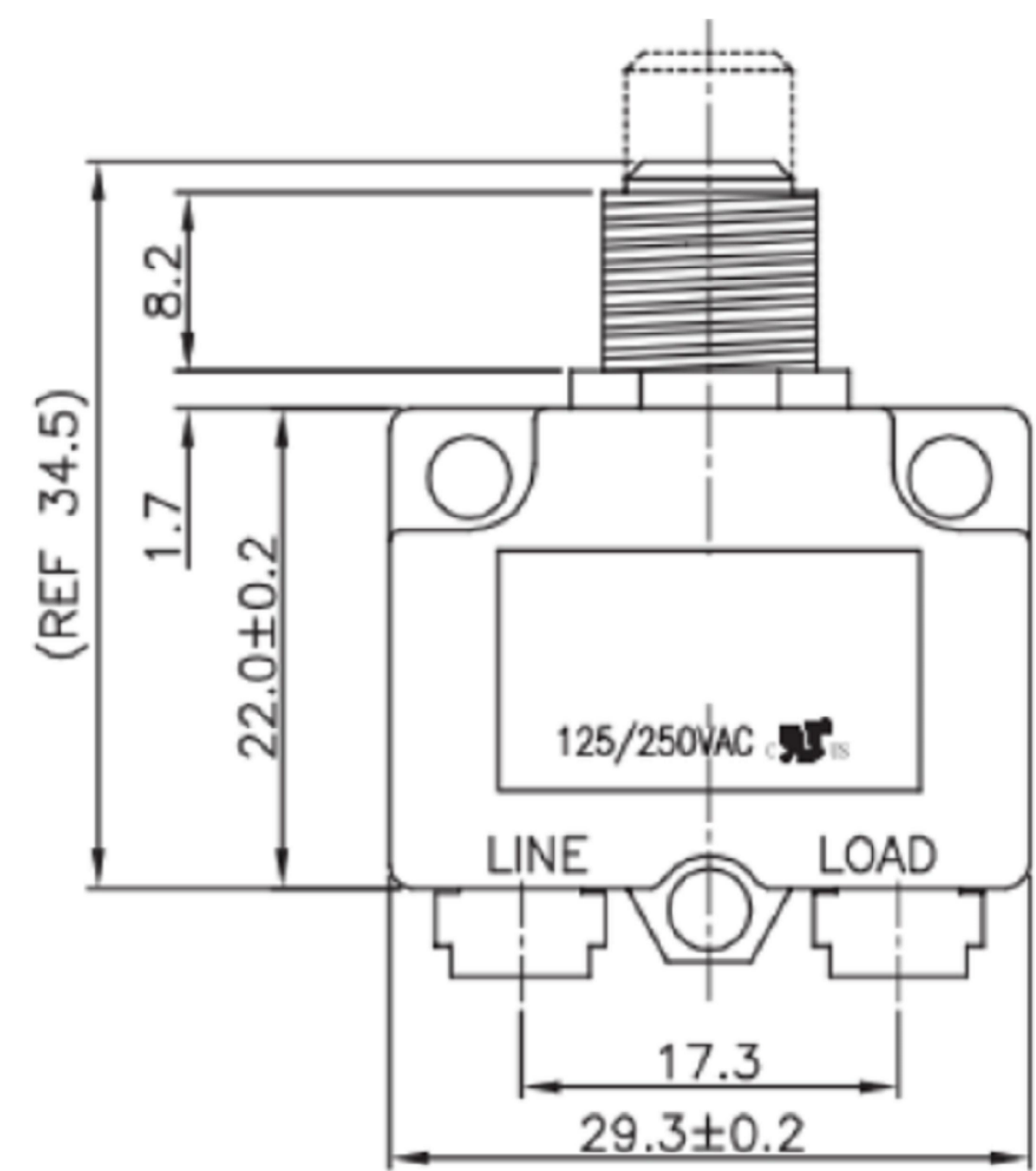

Percent of Rated Current Trip Curves Are Specified of 25

Model Number	Current Rating	Overload Percentage	Trip Time(in seconds) VS Amperes at+25
RTB series	3~20A	100%	NO. Trip
		150%	Trip in 1 hours
		200%	10~40
		300%	1.2~12
		400%	0.6~5.0
		500%	0.4~2.8
		600%	0.3~1.8

SPECIFICATION 规格:

1. Rating:3A-20A
2. Certifications:UL,CUL
3. Resetable overload capacity:10 times rated current
4. Reset Time:1 minute min.
5. Dielectric Strength:1500VAC ohms 0.5mA 1 minutes
6. Insulation Resistance:100M ohms
7. Voltage Drop:Less than 0.25V Temperature Rise atTerminal Block
8. Less than 117 o F (65°C) at 100% of rated current
- 9.Applied continuously at 70° F (25°C)

广东科斯达电子科技有限公司  
GUANG DONG KE SI DA ELECTRONIC TECHNOLOGY CO., LTD.

TOLERANCE UNLESS OTHERWISE STATED:  
 Up to 5 ±0.2  
 Above 5 ~ 15 ±0.3  
 Above 15 ~ 30 ±0.4  
 Above 30 ~ 50 ±0.5  
 Angle ±0.3°

3RD. ANGEL'S

UNITS MM

DRAWN BY:	DATE	MAT'L	TITLE	SWITCH
Ming Ming Zou	07/10/13			
CHECKED BY:	DATE	FINISH	MODLE	SWITCH
Ning Ning Su	07/10/13			
APPROVED BY:	DATE	SCALE	DWG NO.	KSD-RTB-20B1BNKNFA-BF
Jia Xiang	07/10/13	2:1		
SHEET NO.	1 of 1	PART NO.		

1	更新開關位置	Jack	071013
ITEM NO.	DESCRIPTION	DRAWN	DATE