

NOTES:

1.MATERIAL:

MOLDING: LCP UL94 V-0
 CONTACT: COPPER ALLOY.
 GOLD PLATED Min ON CONTACT AREA, 100u"
 Min TIN (LEAD FREE) ON SOLDER AREA,
 SHELL: SUS304-H, T=0.30±0.03mm
 50u" NICKEL PLATING OVER ALL.

2.MECHANICAL:

INSERTION: 5~20N.
 EXTRACTION: 8~20N AFTER TEST.
 DURABILITY: 10000 CYCLES

3.ELECTRICAL:

CURRENT: 3A FOR VBUS;
 1.25A FOR GND PIN.
 0.25A FOR OTHER.
 VOLTAGE: 20 V MAX
 WITHSTANDING VOLTAGE: 100V AC R.M.S.
 CONTACT RESISTANCE: 40mΩ MAX.
 INSULATION RESISTANCE: 100MΩ MIN.

4.ENVIRONMENTAL

TEMPERATURE RANGE -25°C ~ +85°C

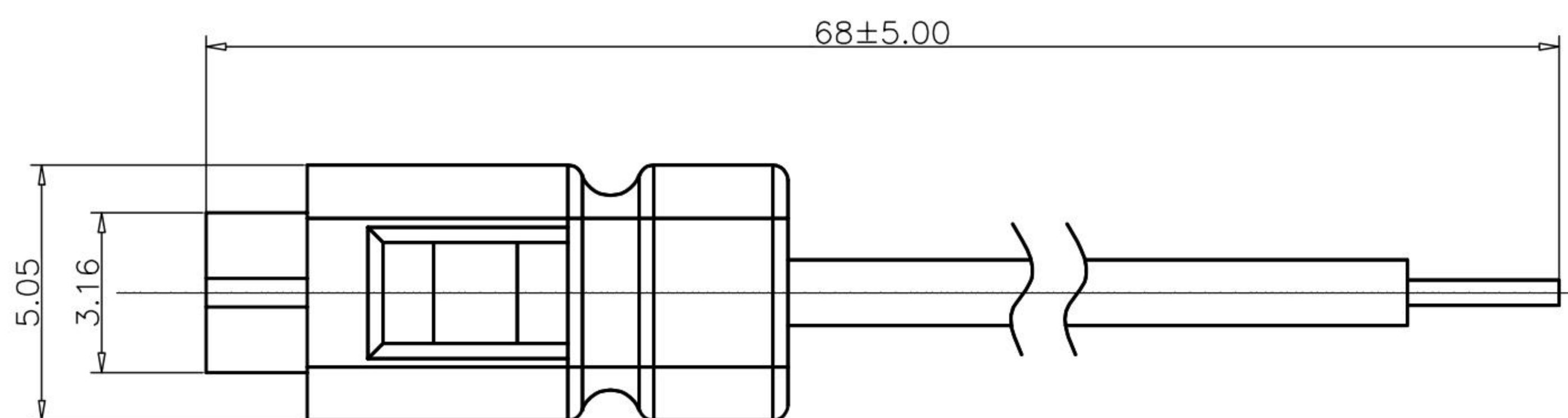

4	更新pcb layout尺寸	Jack	083019
3	新增pcb layout尺寸	Jack	082919
2	更新料號	Jack	061219
1	更新圖面樣式及尺寸	Jack	091818
ITEM NO.	DESCRIPTION	DRAWN	DATE

广东科斯达电子科技有限公司
 GUANG DONG KE SI DA ELECTRONIC TECHNOLOGY CO., LTD.

TOLERANCE UNLESS OTHERWISE STATED:
 Up to 5 ±0.2
 Above 5 ~ 15 ±0.3
 Above 15 ~ 30 ±0.4
 Above 30 ~ 50 ±0.5
 Angle ±0.3°

3RD. ANGEL'S

UNITS MM

DRAWN BY:	DATE	MAT'L	TITLE	CONNECTOR
Ming Ming Zou	11/19/14			
CHECKED BY:	DATE	FINISH	MODLE	USB C TYPE
Ning Ning Su	11/19/14			
APPROVED BY:	DATE	SCALE	DWG NO.	SIZE
Jia Xiang	11/19/14	1:1		A4
		SHEET NO.	PART NO.	VER
		1 of 1		R4