

Rating: 3~20A 125/250VAC
UL CUL: E321127

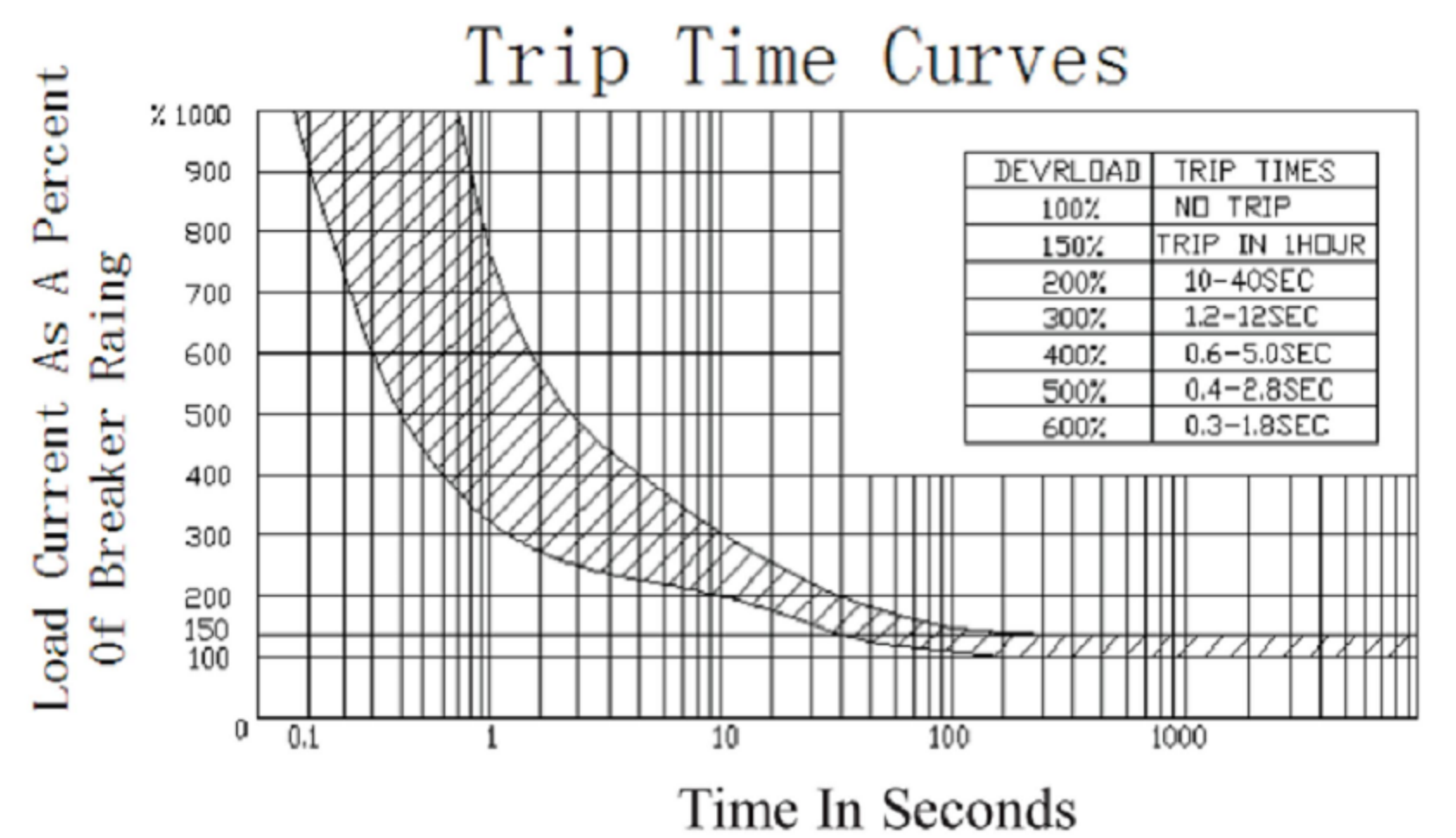

Percent of Rated Current Trip Curves Are Specified of 25

Model Number	Current Rating	Overload Percentage	Trip Time(in seconds) VS Amperes at+25
RTB series	3~20A	100%	NO. Trip
		150%	Trip in 1 hours
		200%	10~40
		300%	1.2~12
		400%	0.6~5.0
		500%	0.4~2.8
		600%	0.3~1.8

RTB- **B4BNBNFA
安培數(03~20)

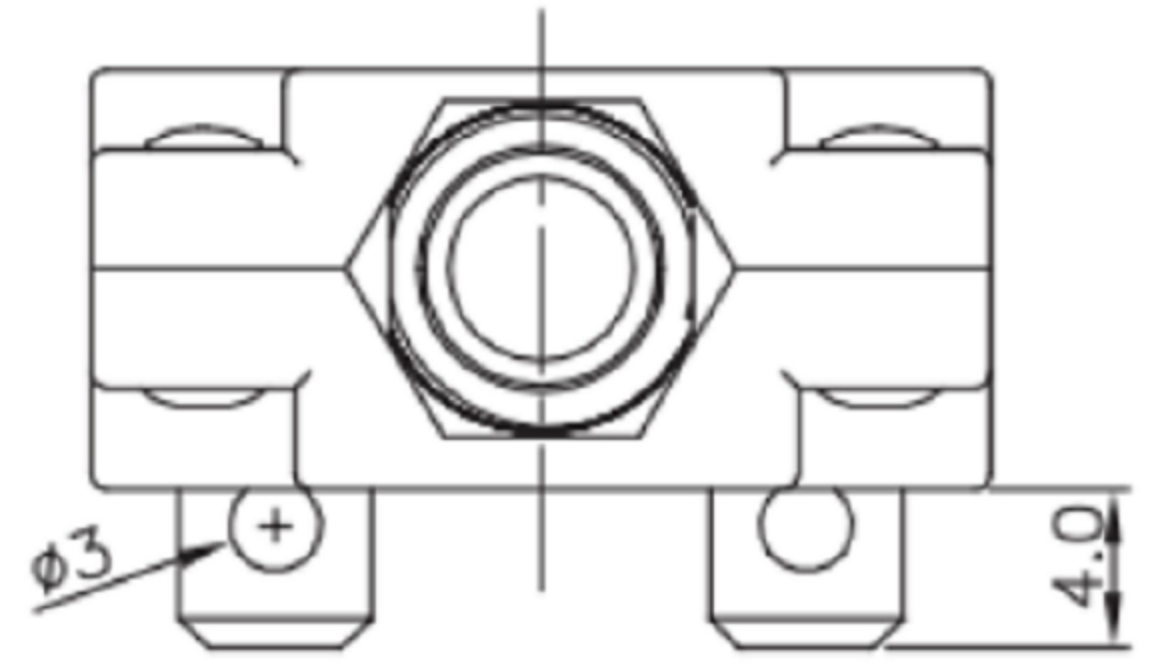
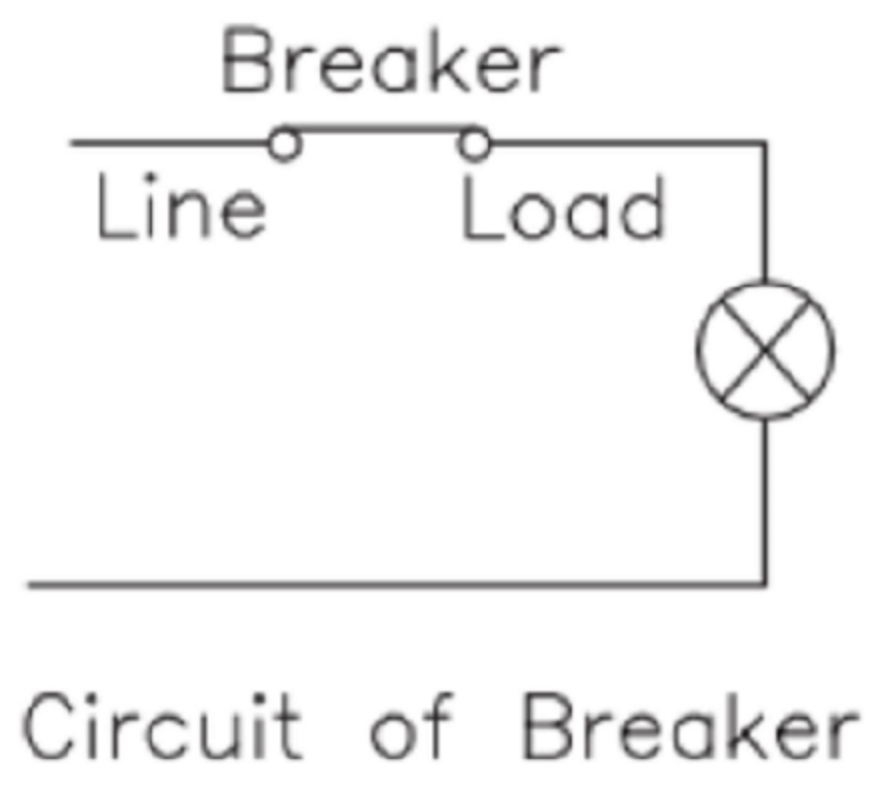

SPECIFICATION 規格:

1. Rating: 3A-20A
2. Certifications: UL, CUL
3. Resettable overload capacity: 10 times rated current
4. Reset Time: 1 minute min.
5. Dielectric Strength: 1500VAC ohms 0.5mA 1 minutes
6. Insulation Resistance: 100M ohms
7. Voltage Drop: Less than 0.25V Temperature Rise at Terminal Block
8. Less than 117 o F (65°C) at 100% of rated current
9. Applied continuously at 70° F (25°C)

广东科斯达电子科技有限公司
GUANG DONG KE SI DA ELECTRONIC TECHNOLOGY CO., LTD.

TOLERANCE UNLESS OTHERWISE STATED:
Up to 5 ±0.2
Above 5 ~ 15 ±0.3
Above 15 ~ 30 ±0.4
Above 30 ~ 50 ±0.5
Angle ±0.3°

3RD. ANGEL'S

UNITS MM

DRAWN BY: Ming Ming Zou 07/10/13
CHECKED BY: Ning Ning Su 07/10/13
APPROVED BY: Jia Xiang 07/10/13

MAT'L	TITLE SWITCH
FINISH	MODLE SWITCH
SCALE 2:1	DWG NO.
SHEET NO. 1 of 1	PART NO.

1	更新開關位置	Jack	071013
ITEM NO.	DESCRIPTION	DRAWN	DATE

SIZE A4
VER R1