

REV.	ECO NO.	DATE	SIGN	DESCRIPTION
A		2009.07.01		NEW DRAWING

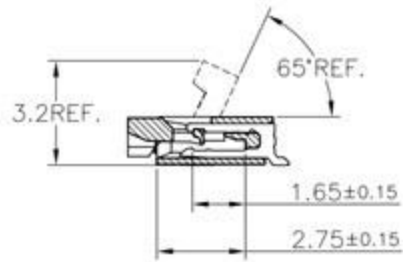

SECTION A-A

- NOTES:
- MATERIAL:
HOUSING: HIGHT-TEMP PLASTIC,UL 94-V0,COLOR:NATURE;
COVER: HIGHT-TEMP PLASTIC,UL 94-V0,COLOR:BLACK;
CONTACT: COPPER ALLOY;
LEG: COPPER ALLOY;
 - PLATING:
CONTACT: GOLD OR TIN PLATED ON NICKEL OVERALL.
LEG: TIN PLATED ON NICKEL OVERALL.
 - RATING:
CURRENT RATING: 0.5A AC/DC
VOLTAGE RATING: 25V AC/DC
TEMPERATURE RANGE: -25°C~+85°C;
 - PART NO:

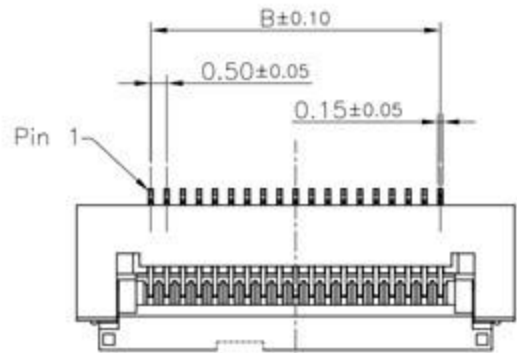
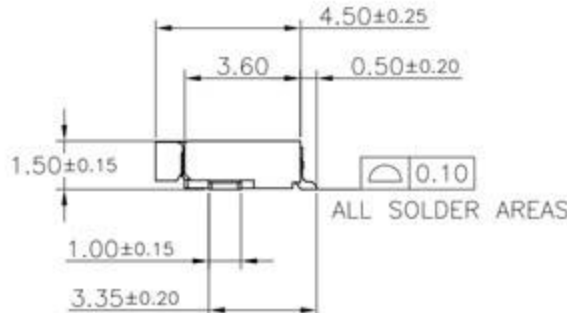
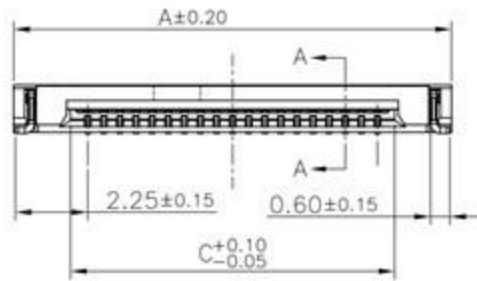

ALL SOLDER AREAS

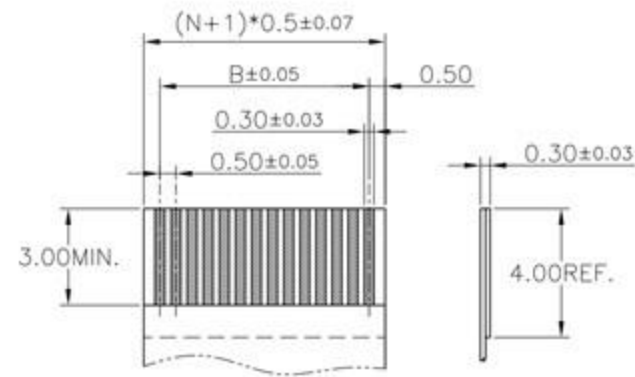

APPLICABLE FFC
TOLERANCE:±0.05

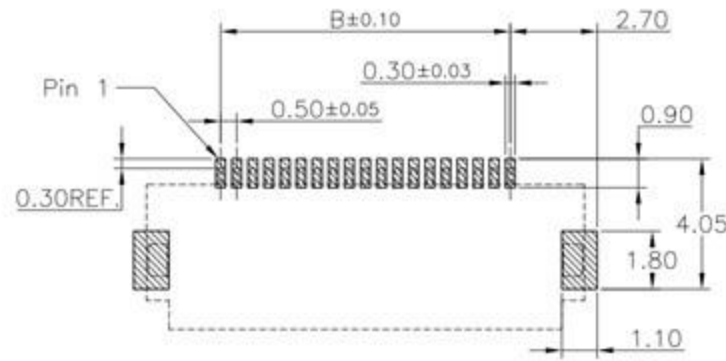

RECOMMEND PCB LAYOUT
TOLERANCE:±0.05

PIN NO.	DIM. A	DIM. B	DIM. C
14	11.10	6.50	7.57
15	11.60	7.00	8.07
16	12.10	7.50	8.57
17	12.60	8.00	9.07
18	13.10	8.50	9.57
19	13.60	9.00	10.07
20	14.10	9.50	10.57
21	14.60	10.00	11.07
22	15.10	10.50	11.57
23	15.60	11.00	12.07
24	16.10	11.50	12.57
25	16.60	12.00	13.07

TOLERANCE UNLESS SPECIFIED		DATE 2009.07.01	DAR. BY	MATERIAL ---
LINEAR	ANGLE	SCALE 1/1	CHK. BY	FINISH ---
.X ±0.25	X° ±2°	UNIT mm	APP. BY	PART NO. ---
.XX ±0.15	.X° ±2°			
.XXX ±0.10	.XX° ±---			

廣東科斯達電子科技有限公司



TITLE: FPC 0.5Pitch 1.5H掀蓋式 connector
DWG NO. REV. A