

序号	品名	材质
①	0.5拉拔胶芯 (H1.2)	LCP UL94V-0 本色
②	0.5拉拔下接端子 (H1.2)	磷青铜/表面镀锡 镀金
③	0.5拉拔后盖 (H1.2)	LCP UL94V-0 黑色
④	0.5拉拔焊片 (H1.2)	磷青铜/表面镀锡

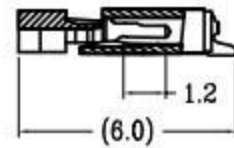

SECTION A-A

CKT	DIM A	DIM B	DIM C	CKT	DIM A	DIM B	DIM C
4	1.50	2.56	7.96	33	16.00	17.06	22.46
5	2.00	3.06	8.46	34	16.50	17.56	22.96
6	2.50	3.56	8.96	35	17.00	18.06	23.46
7	3.00	4.06	9.46	36	17.50	18.56	23.96
8	3.50	4.56	9.96	37	18.00	19.06	24.46
9	4.00	5.06	10.46	38	18.50	19.56	24.96
10	4.50	5.56	10.96	39	19.00	20.06	25.46
11	5.00	6.06	11.46	40	19.50	20.56	25.96
12	5.50	6.56	11.96	41	20.00	21.06	26.46
13	6.00	7.06	12.46	42	20.50	21.56	26.96
14	6.50	7.56	12.96	43	21.00	22.06	27.46
15	7.00	8.06	13.46	44	21.50	22.56	27.96
16	7.50	8.56	13.96	45	22.00	23.06	28.46
17	8.00	9.06	14.46	46	22.50	23.56	28.96
18	8.50	9.56	14.96	47	23.00	24.06	29.46
19	9.00	10.06	15.46	48	23.50	24.56	29.96
20	9.50	10.56	15.96	49	24.00	25.06	30.46
21	10.00	11.06	16.46	50	24.50	25.56	30.96
22	10.50	11.56	16.96	51	25.00	26.06	31.46
23	11.00	12.06	17.46	52	25.50	26.56	31.96
24	11.50	12.56	17.96	53	26.00	27.06	32.46
25	12.00	13.06	18.46	54	26.50	27.56	32.96
26	12.50	13.56	18.96	55	27.00	28.06	33.46
27	13.00	14.06	19.46	56	27.50	28.56	33.96
28	13.50	14.56	19.96	57	28.00	29.06	34.46
29	14.00	15.06	20.46	58	28.50	29.56	34.96
30	14.50	15.56	20.96	59	29.00	30.06	35.46
31	15.00	16.06	21.46	60	29.50	30.56	35.96
32	15.50	16.56	21.96				

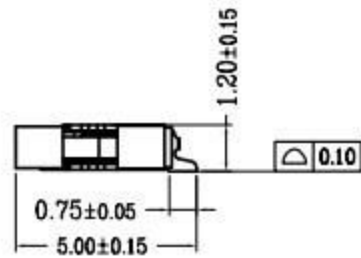
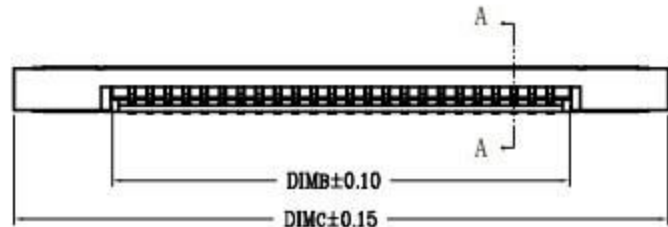
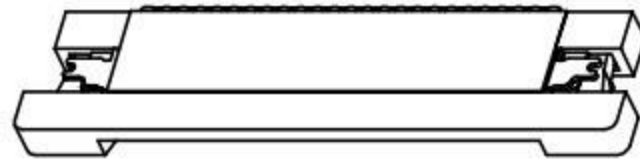
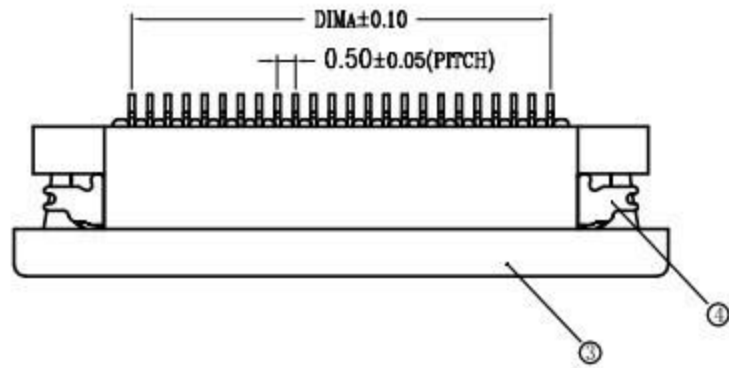
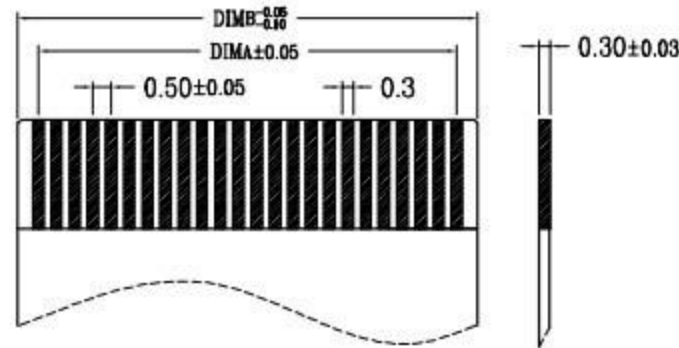
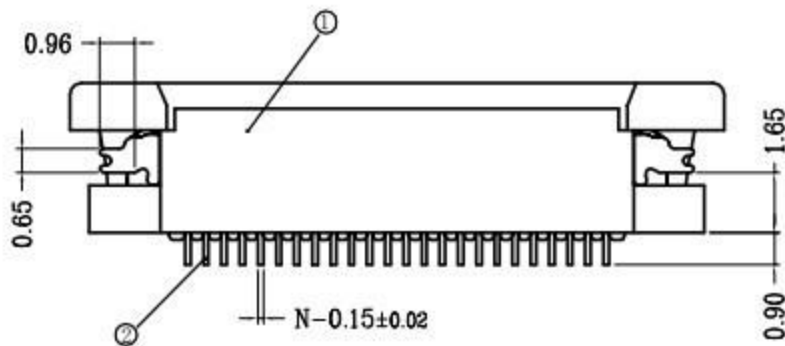

适用扁平线

1. MATERIAL
 HOUSING:LCP UL94V-0
 ACTUATOR:LCP UL94V-0
 CONTACTS:COPPER ALLOY
 PEG:COPPER ALLOY
 2. PLATING:
 CONTACTS:TIN OVER NICKEL
 PEG:TIN OVER NICKEL
 3. PART NO:
 OPERATING VOLTAGE:50V AC, DC
 CURRENT RATING:0.3A AC, DC
 OPERATING TEMPERATURE:-25C~+85C

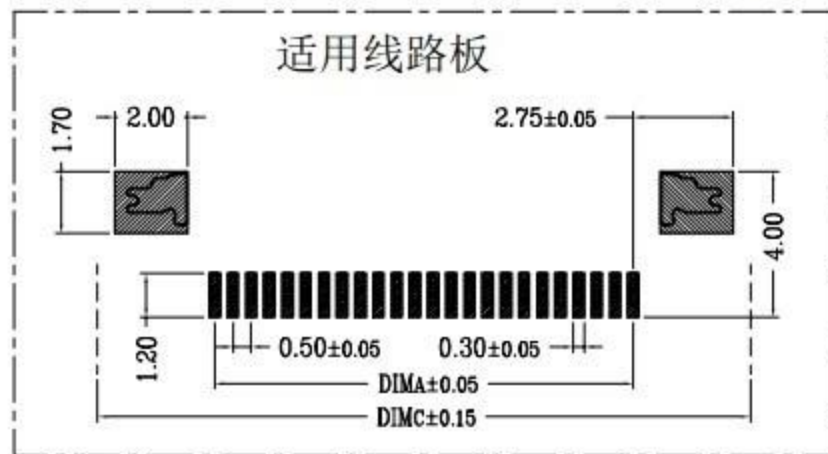

适用线路板

UNITS mm		廣東科斯達電子科技有限公司		
MAT'L				
PART NO.(INTENDED USE)		TITLE: 0.5 Pitch拉拔卧式下接(H=1.2)		
APPD:		DWG NO.:		
FINISH		CHKD:		
Q'TY PCS		DR: HU 2016.09.28		
X ± 0.3	X' ± 5'	SCALE	SHEET	REV.
.X ± 0.25	.X' ± 2'	1/1	1/1	A
.XX ± 0.20	.XX' ± 1'			
.XXX ± 0.10	.XXX' ± 0.5'			