

**Switch Specifications**

Circuit	:SPST
Current rating	:50mA
Voltage rating	:12VDC
Dielectric withstanding voltage	:250VAC for 1 minute
Contact resistance	:30mΩ Max. (Initial)
Insulation resistance	:100MΩ Min.
Operating force	:250±50gf
	:180±50gf
Total travel	:0.25mm±0.1mm
Operating life	:100,000 cycles Min
Solder specifications	:256° C for 5 seconds
Function	:Momentary
Operating temperature	:-20° C ~ +70° C
Welding method	:Manual Soldering (350° C±5° C, 3s±0.5s)
	:Reflow soldering

**P.C.B. LAYOUT**

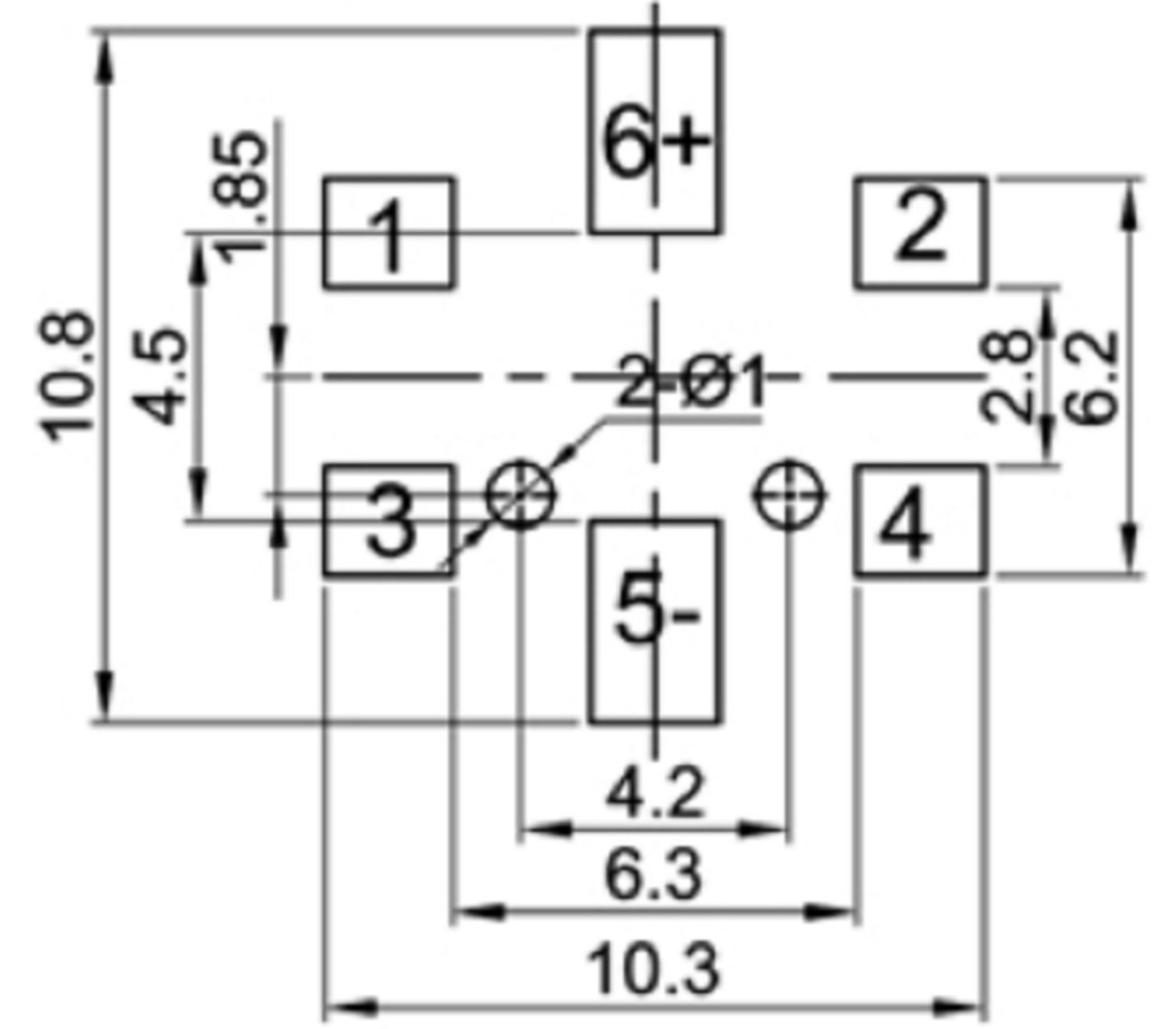

**CIRCUIT**

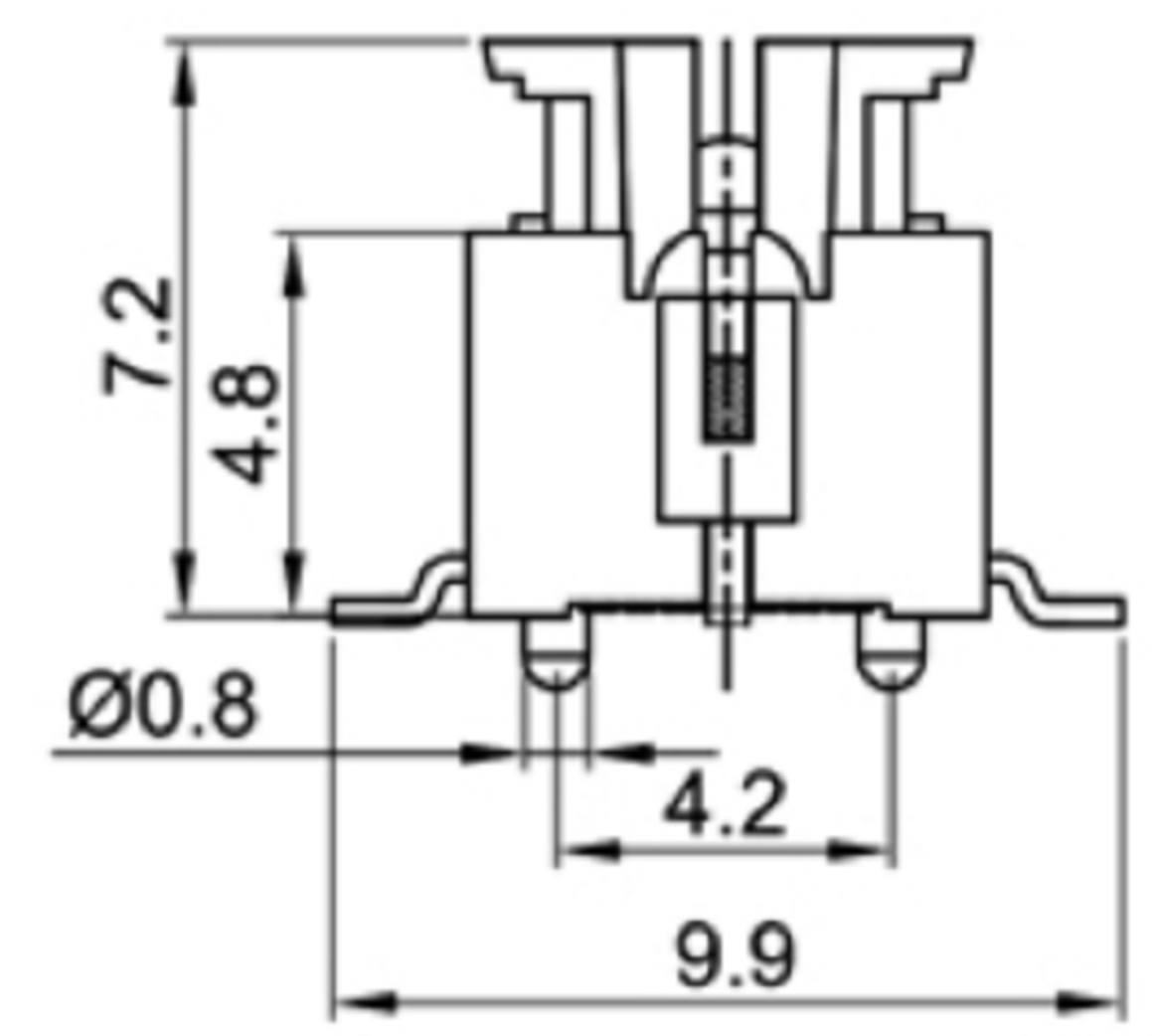
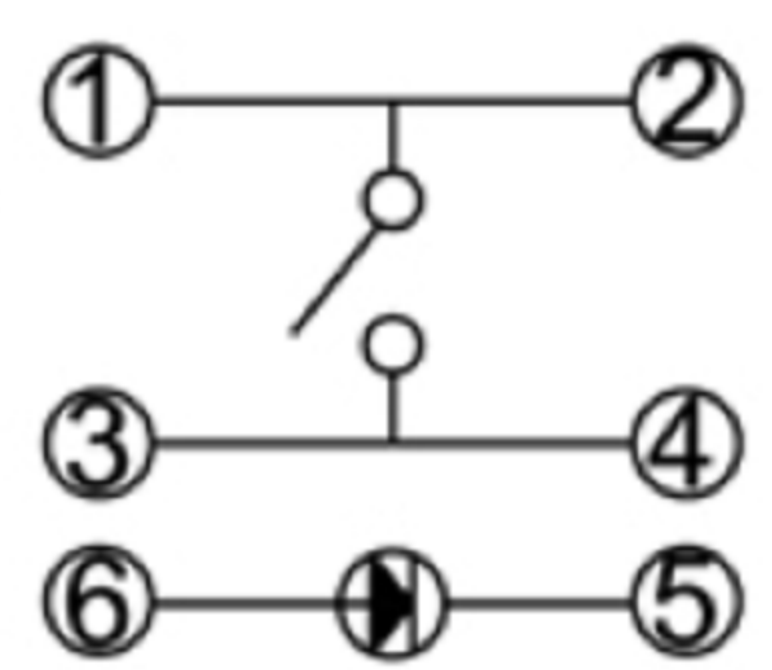

**LED Specifications**

W	白色	2.8	3.4	3.8	20	120
U	蓝色	2.8	3.2	3.4	20	120
G	黄绿色	1.8	2.2	2.4	20	120
Y	黄色	1.8	2.2	2.4	20	120
R	红色	1.8	2.2	2.4	20	120
灯发光颜色 X Emitted color X	最小	一般	最大	最大操作电流 (mA)	最大脉冲电流 (mA)	
	顺向电压(V)					

**MATERIAL:**

Base Frame: Nylon66, UL rated:94 V-2. ;  
 Actuator: Nylon66, UL rated:94 V-2. ;  
 Terminal: Brass, Silver or Tin plated .

NO.	DESCRIPTION	QTY	MATERIAL	PLATING
7	CAP	1	ABS / PC	Black
6	LED	1		
5	FIXITY	1	PA66	Black
4	CONTACT	1	PHOSPHOR BRONZE	Ag plated
3	TERMINAL	2	BRASS	Ag plated
2	CASE	1	PA66	Black
1	KNOB	1	PA66	Black/White

**广东科斯达电子科技有限公司**  
 GUANG DONG KE SI DA ELECTRONIC TECHNOLOGY CO., LTD.

TOLERANCE UNLESS OTHERWISE STATED:	Up to 5 ±0.2	Above 5 ~ 15 ±0.3	Above 15 ~ 30 ±0.4	Above 30 ~ 50 ±0.5	Angle ±0.3
	3RD. ANGEL'S		UNITS	MM	

DRAWN BY:	DATE	MAT'L	TITLE	SWITCH
Jack Lu	12/27/22			
CHECKED BY:	DATE	FINISH	MODLE	TACT SWITCH WITH LED
Jacky Chen	12/27/22			
APPROVED BY:	DATE	SCALE	DWG NO.	SIZE
Tony Kao	12/27/22	1 : 1		A4
		SHEET NO.	PART NO.	VER
		1 of 1		R

ITEM NO.	DESCRIPTION	DRAWN	DATE