

**P.C.B. LAYOUT**

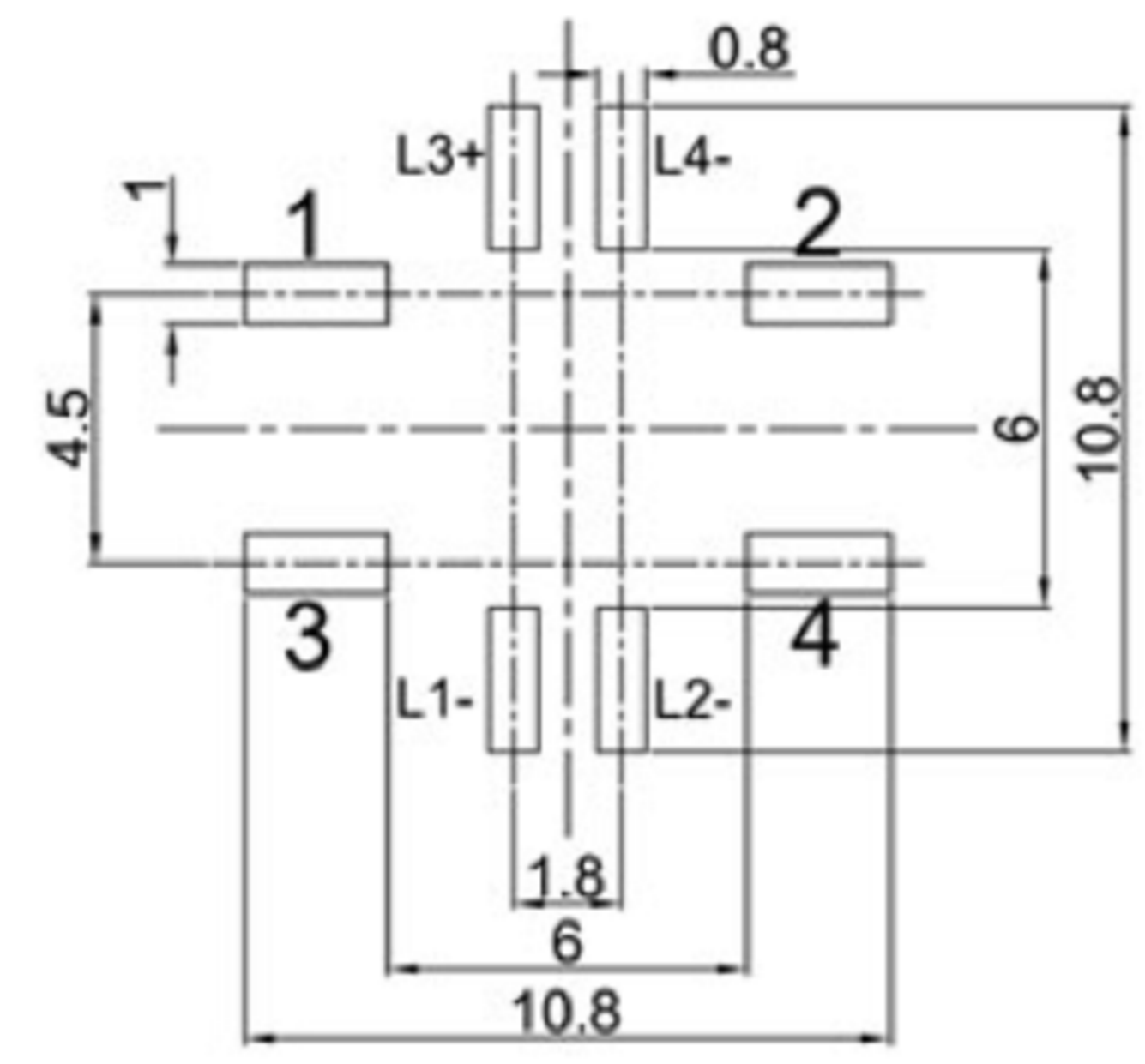

**Switch Specifications**

Circuit	:SPST
Current rating	:50mA
Voltage rating	:12VDC
Dielectric withstanding voltage	:250VAC for 1 minute
Contact resistance	:30mΩ Max. (Initial)
Insulation resistance	:100MΩ Min.
Operating force	:250±50gf
	:180±50gf
Total travel	:0.25mm±0.1mm
Operating life	:100,000 cycles Min
Solder specifications	:260° C for 5 seconds
Function	:Momentary
Operating temperature	:-20° C ~ +70° C
Welding method	:Manual Soldering (350° C±5° C,3s±0.5s)
	:Reflow soldering

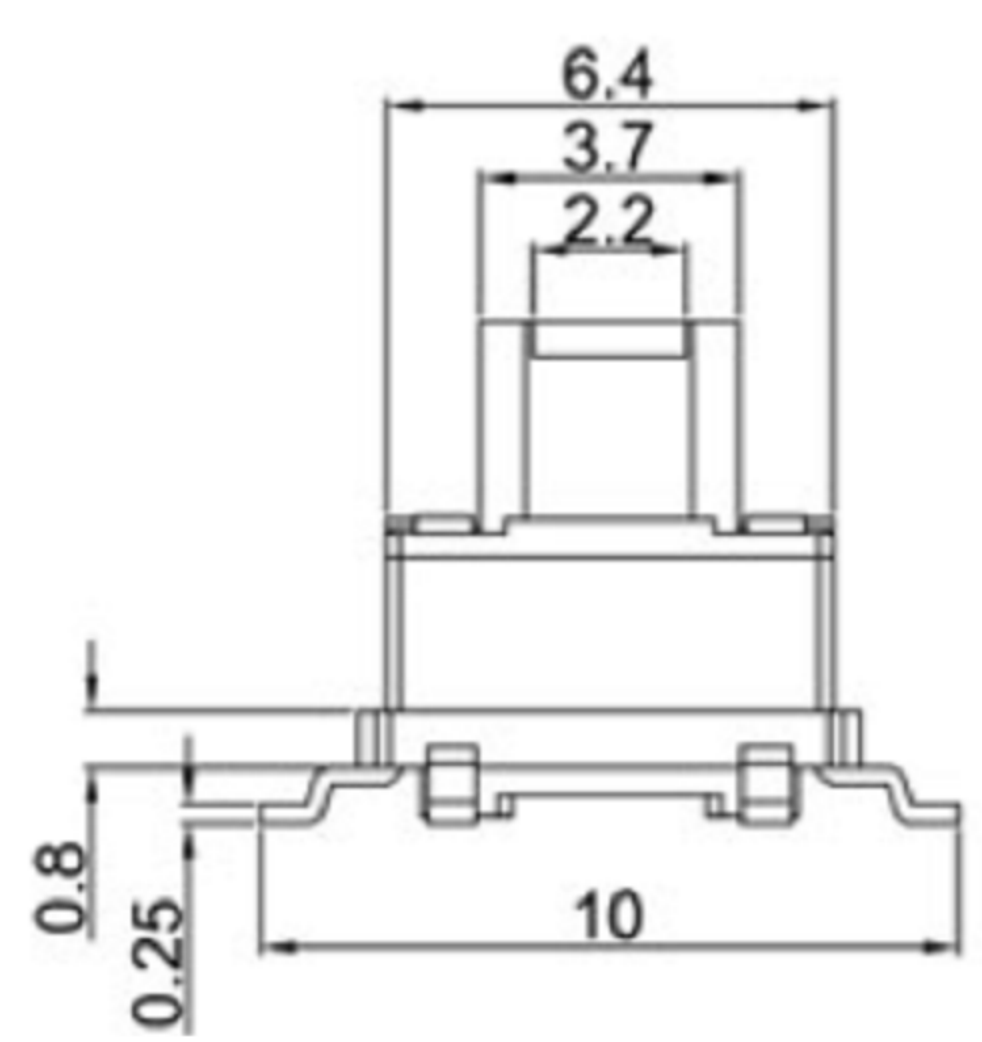
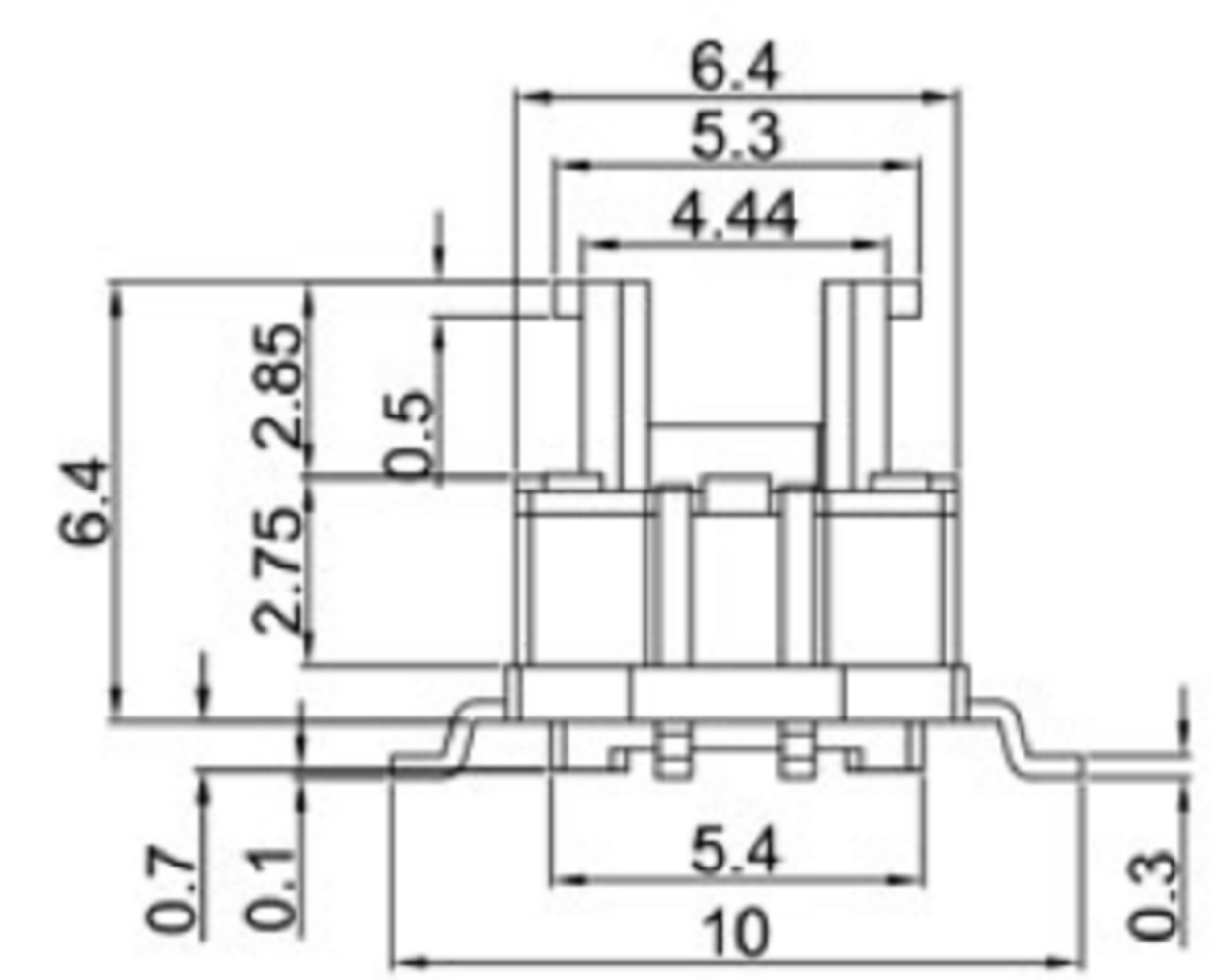

**CIRCUIT**

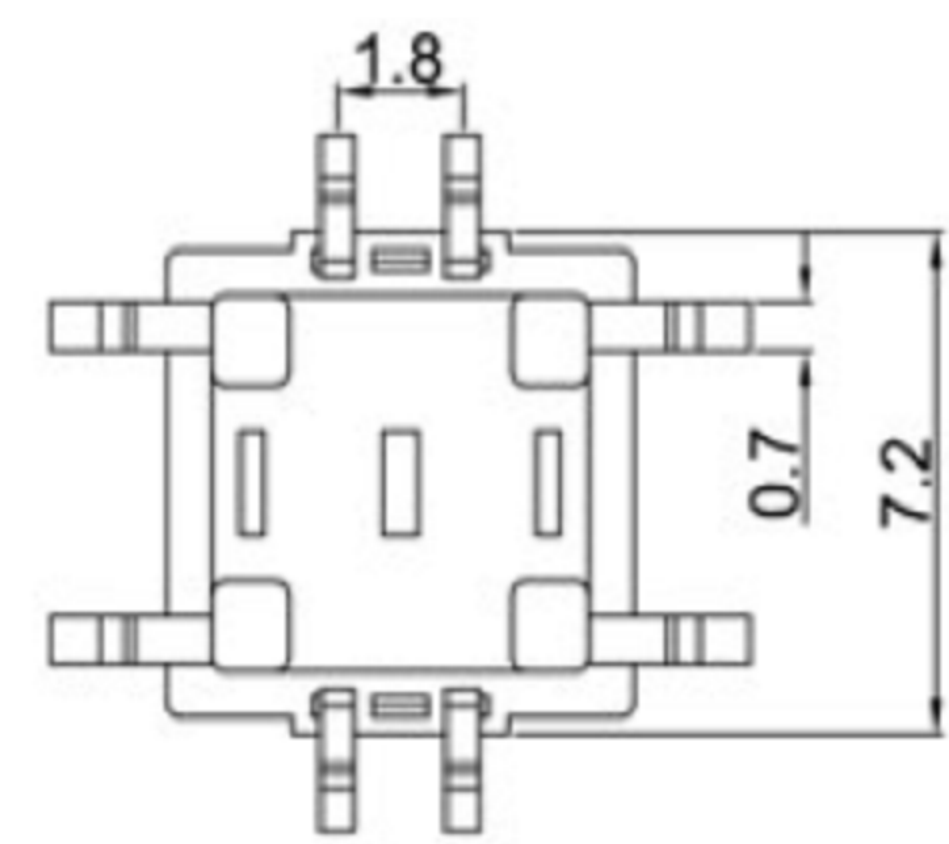
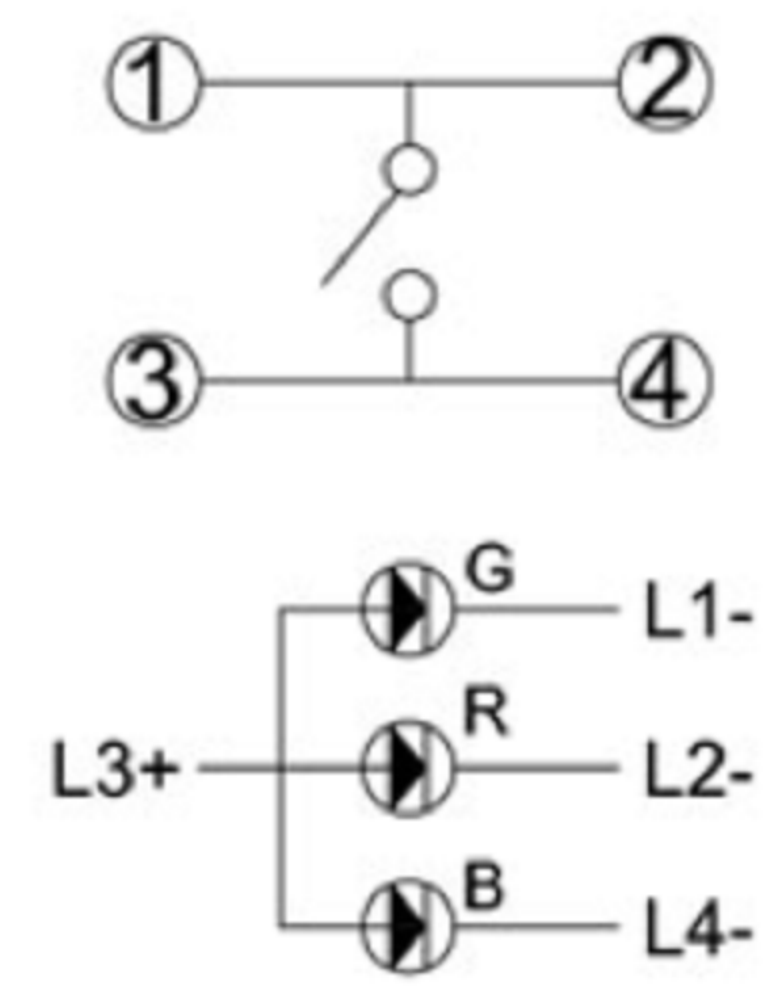

NO.	DESCRIPTION	QTY	MATERIAL	PLATING
7	CAP	1	ABS / PC	Black
6	LED	1		
5	FIXITY	1	PA66	Black
4	CONTACT	1	PHOSPHOR BRONZE	Ag plated
3	TERMINAL	2	BRASS	Ag plated
2	CASE	1	PA66	Black
1	KNOB	1	PA66	Black/White

**广东科斯达电子科技有限公司**  
**GUANG DONG KE SI DA ELECTRONIC TECHNOLOGY CO., LTD.**

TOLERANCE UNLESS OTHERWISE STATED:	Up to 5 ±0.2	Above 5 ~ 15 ±0.3	Above 15 ~ 30 ±0.4	Above 30 ~ 50 ±0.5	Angle ±0.3	3RD. ANGEL'S	UNITS	MM
------------------------------------	--------------	-------------------	--------------------	--------------------	------------	--------------	-------	----

DRAWN BY:	DATE	MAT'L	TITLE	SWITCH
Jack Lu	12/27/22		MODLE	TACT SWITCH WITH LED
CHECKED BY:	DATE	FINISH	DWG NO.	SIZE
Jacky Chen	12/27/22			A4
APPROVED BY:	DATE	SCALE	PART NO.	VER
Tony Kao	12/27/22	1:1		R
		SHEET NO.	1 of 1	

ITEM NO.	DESCRIPTION	DRAWN	DATE