

装配步骤

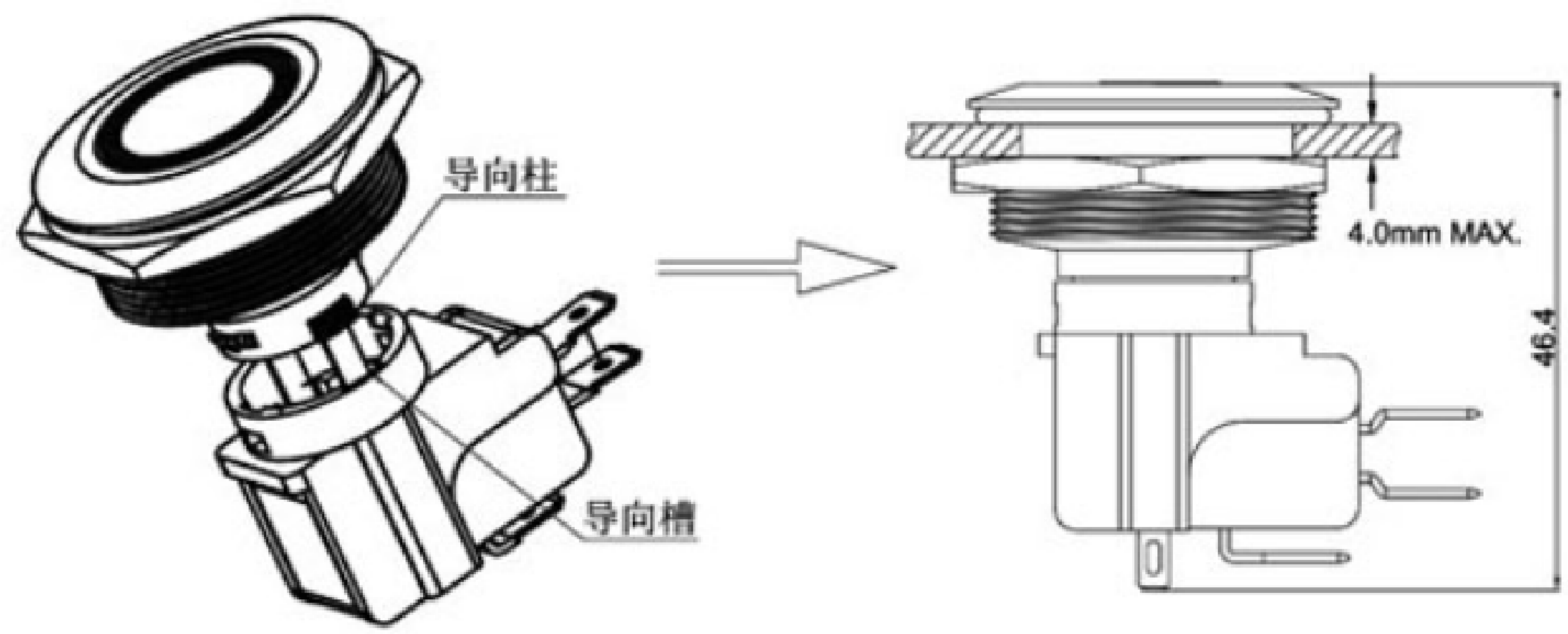

- 装配步骤:
1. 将固定部件装配到面板上，用螺母进行固定。
 2. 将功能部件导向柱与固定部件导向槽对应后进行装配。
 3. 装配后产品总高度如图所示。

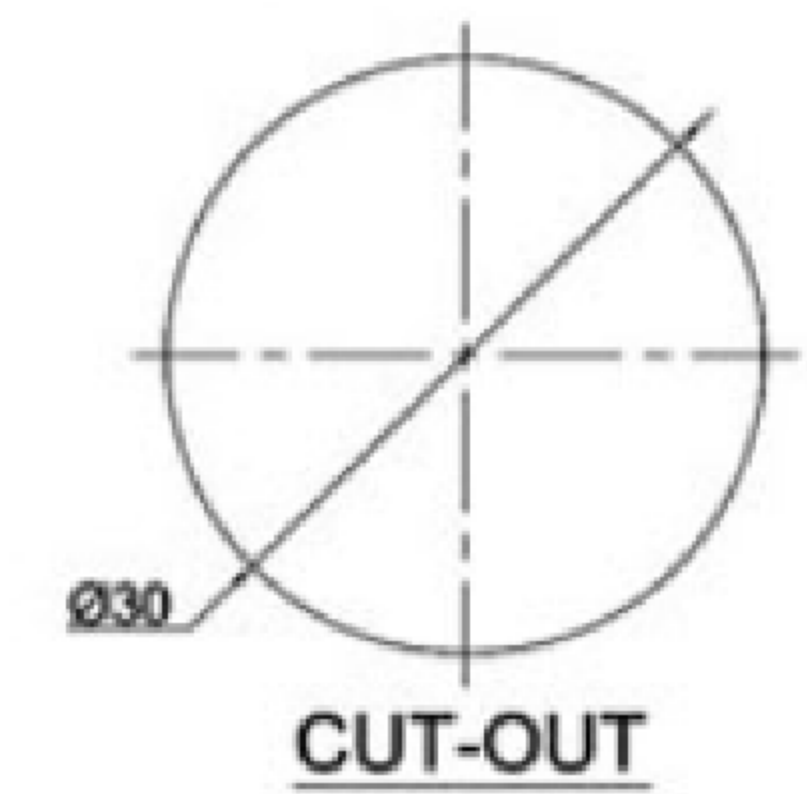
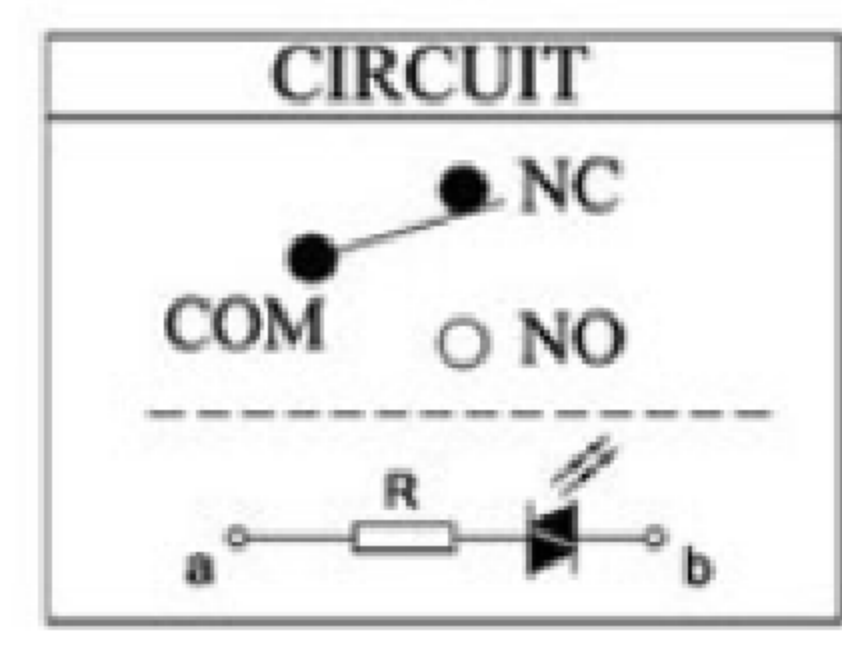

固定部件

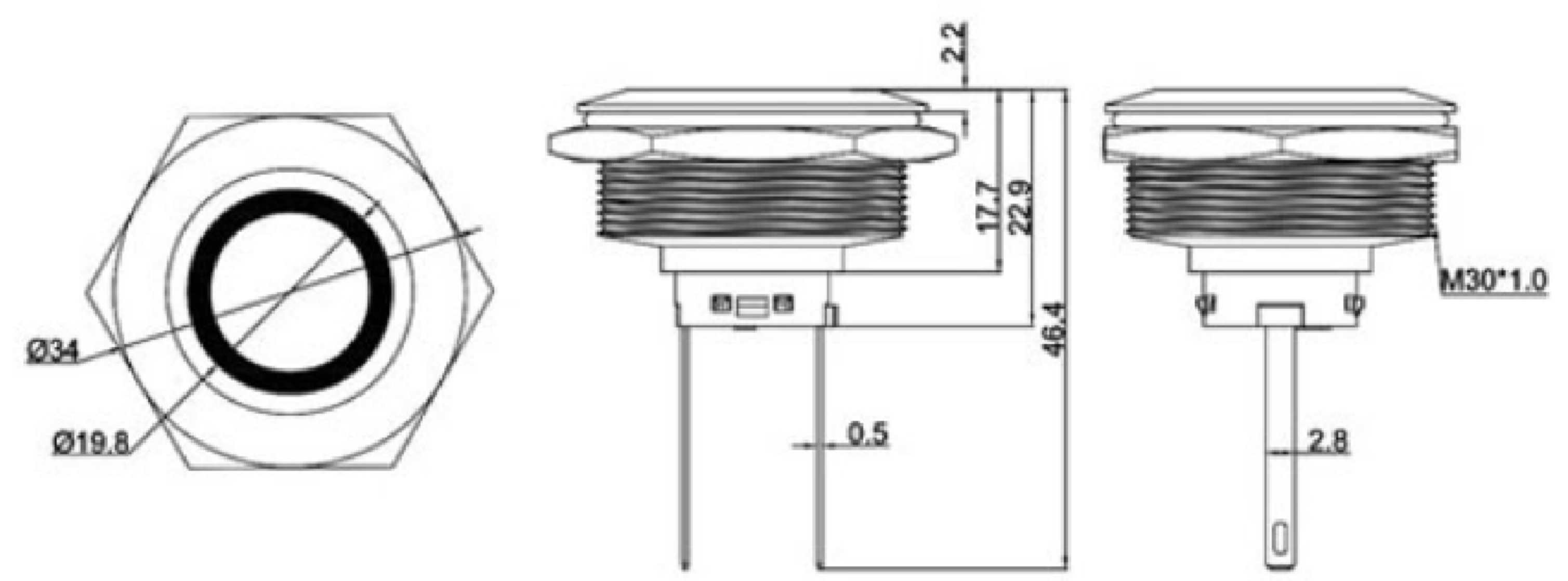

功能部件

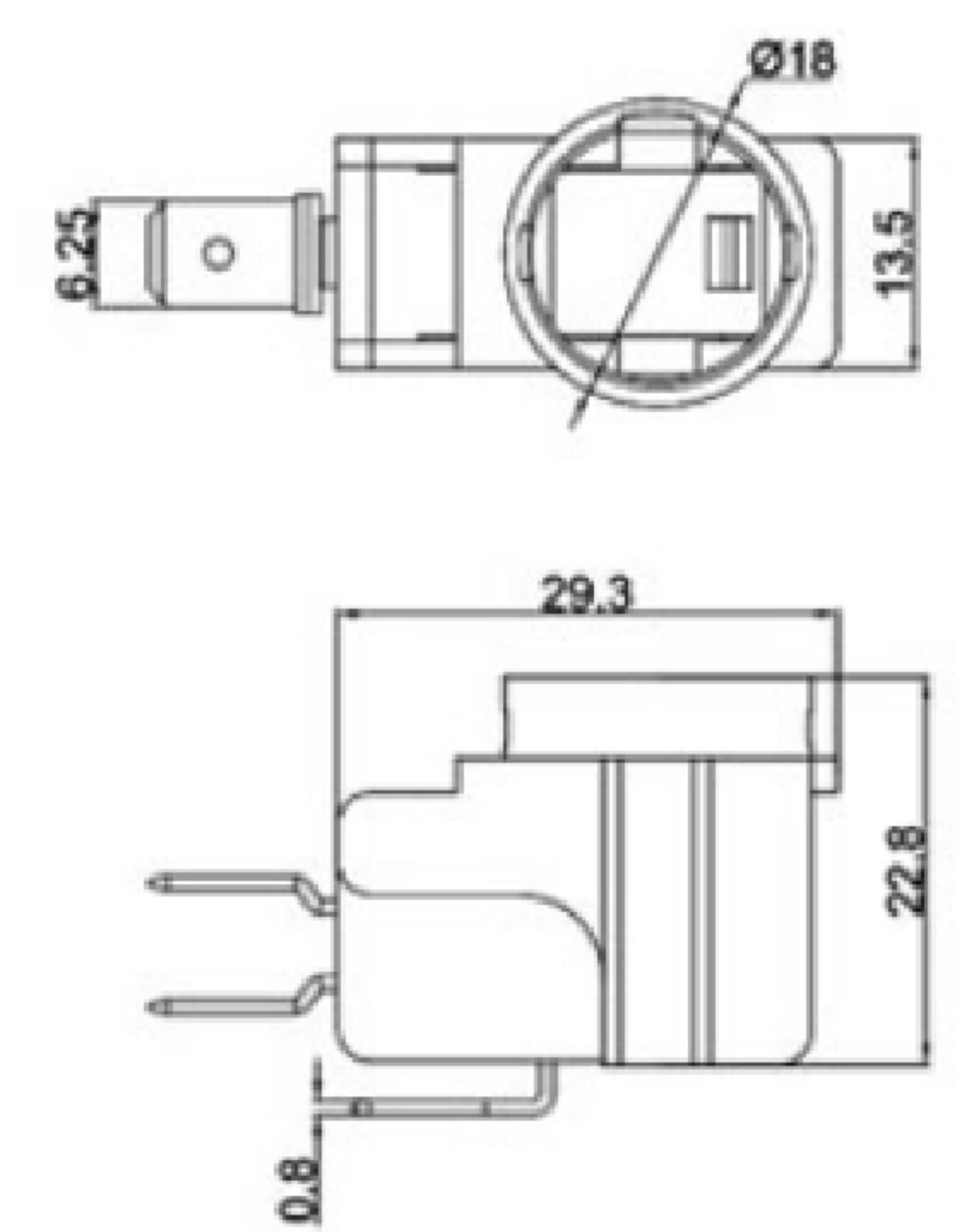

 **广东科斯达电子科技有限公司**
GUANG DONG KE SI DA ELECTRONIC TECHNOLOGY CO., LTD.

TOLERANCE UNLESS OTHERWISE STATED: Up to 5 ±0.2, Above 5 ~ 15 ±0.3, Above 15 ~ 30 ±0.4, Above 30 ~ 50 ±0.5, Angle ±0.3

3RD. ANGEL'S

UNITS MM

DRAWN BY:	DATE	MAT'L	TITLE	SWITCH
Jack Lu	12/27/22		MODLE	TACT SWITCH WITH LED
CHECKED BY:	DATE	FINISH	DWG NO.	SIZE
Jacky Chen	12/27/22			A4
APPROVED BY:	DATE	SCALE	PART NO.	VER
Tony Kao	12/27/22	1:1		R
SHEET NO.	1 of 1			

ITEM NO.	DESCRIPTION	DRAWN	DATE