

装配步骤

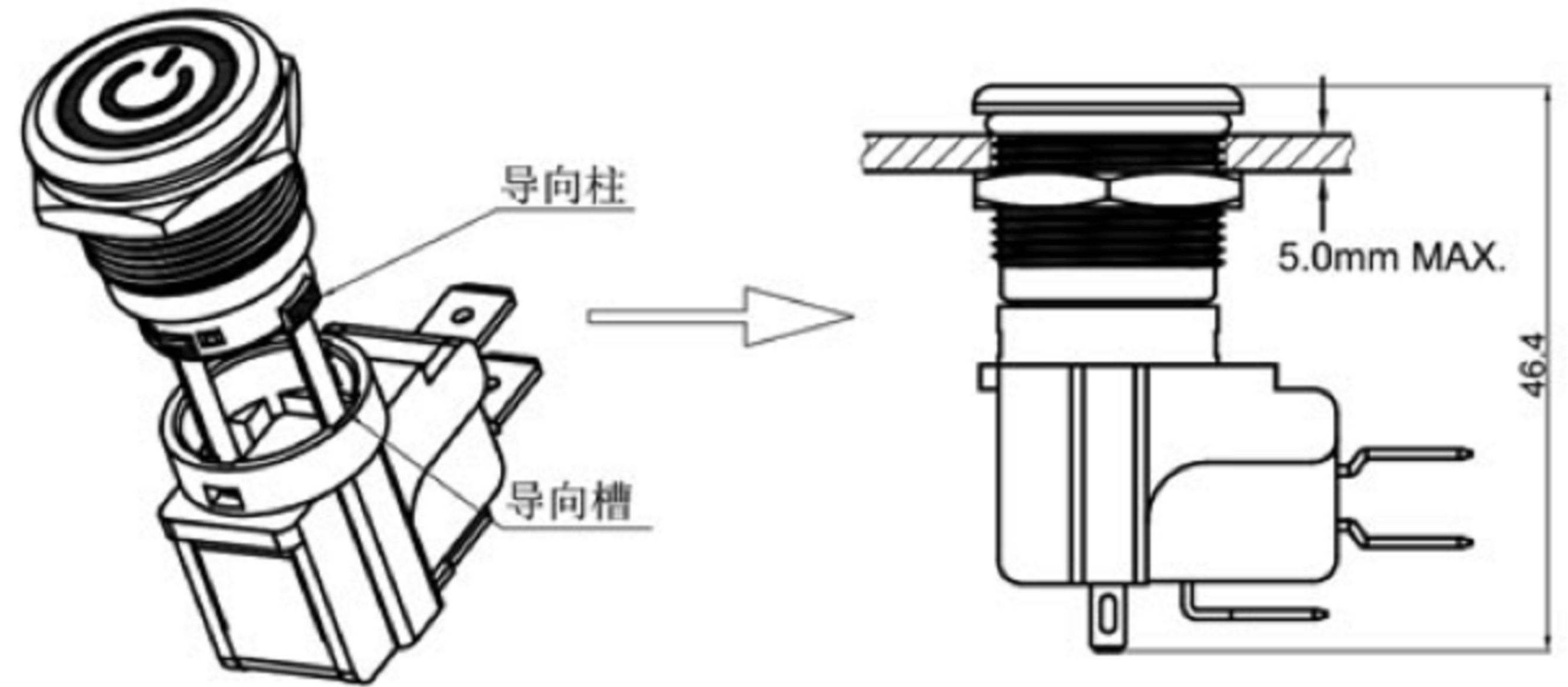

装配步骤:

1. 将固定部件装配到面板上，用螺母进行固定。
2. 将功能部件导向柱与固定部件导向槽对应后进行装配。
3. 装配后产品总高度如图所示。

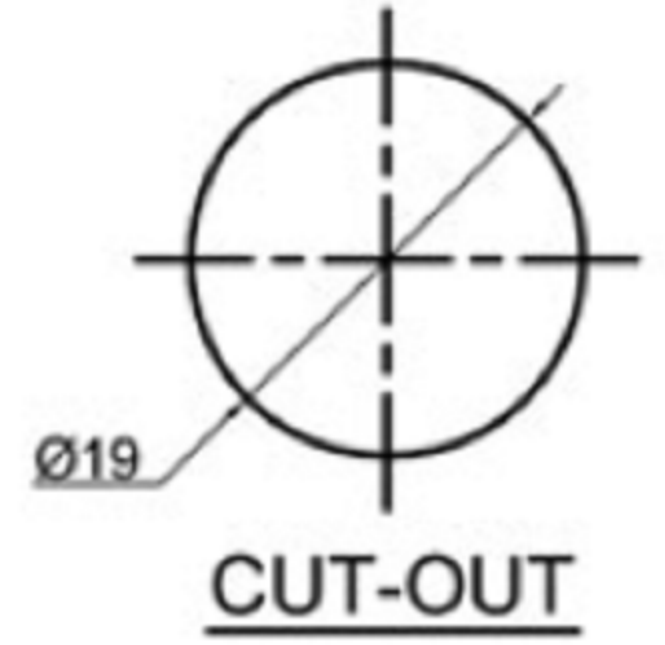
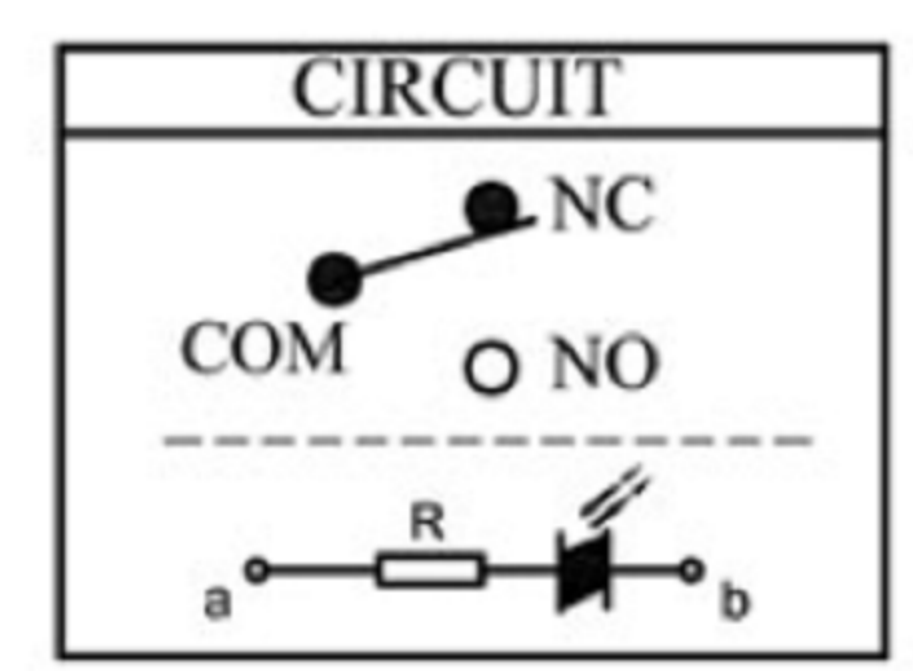

固定部件

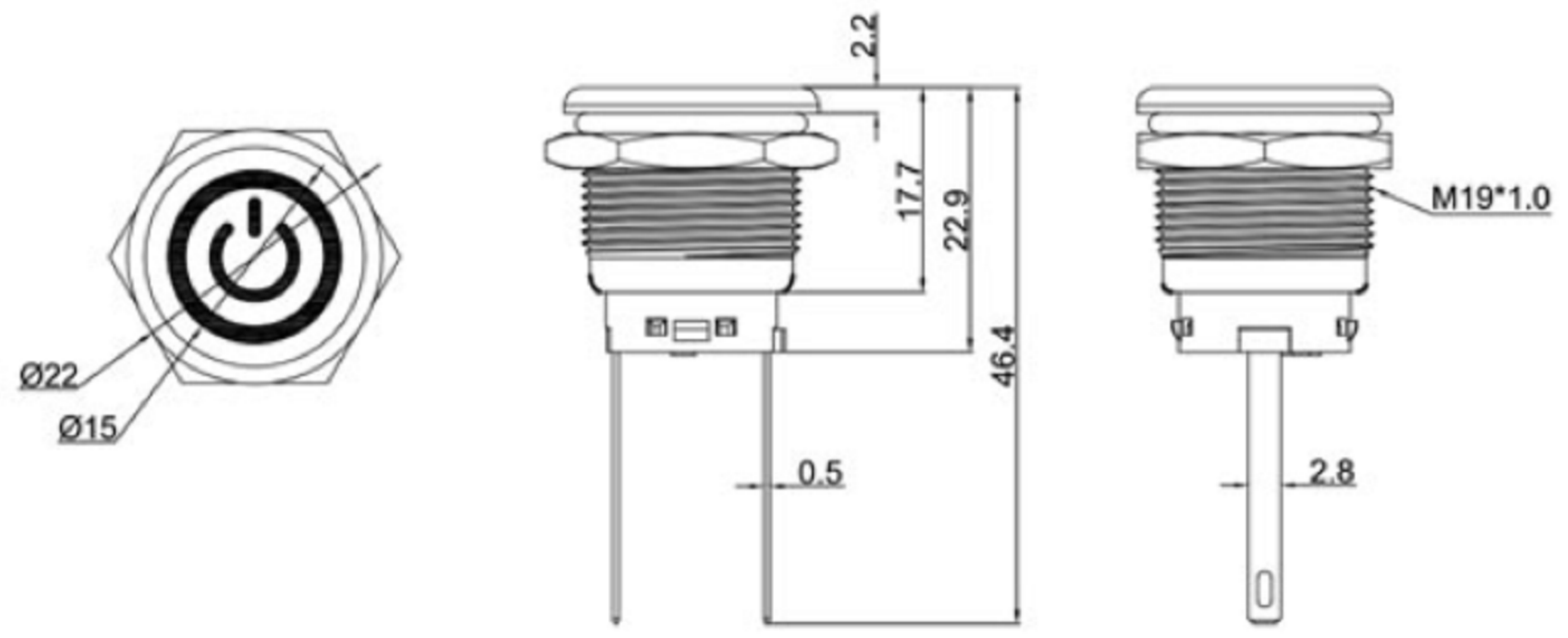

功能部件

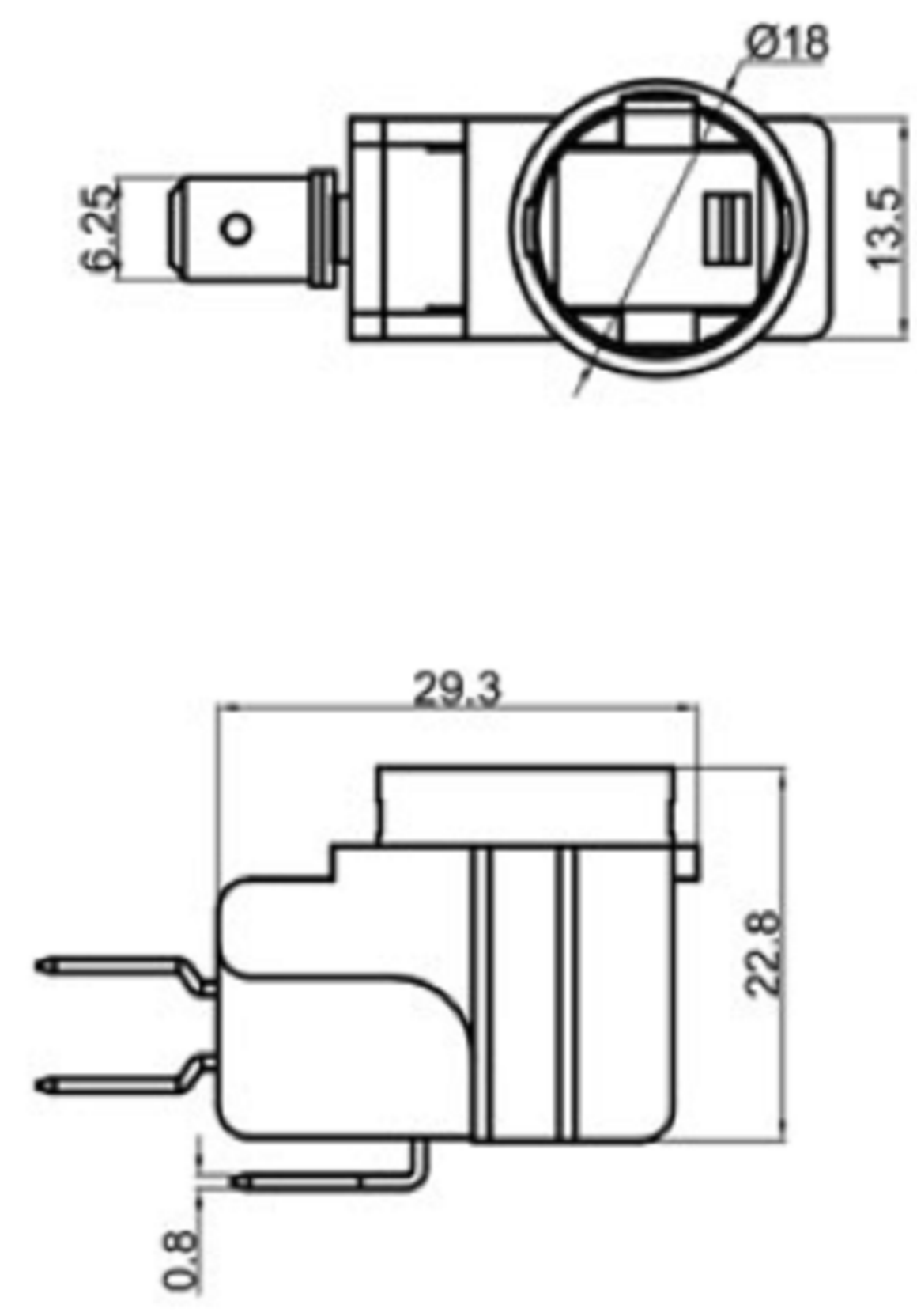

 **广东科斯达电子科技有限公司**
GUANG DONG KE SI DA ELECTRONIC TECHNOLOGY CO., LTD.

TOLERANCE UNLESS OTHERWISE STATED: Up to 5 ±0.2, Above 5 ~ 15 ±0.3, Above 15 ~ 30 ±0.4, Above 30 ~ 50 ±0.5, Angle ±0.3°
 3RD. ANGEL'S UNITS MM

DRAWN BY:	DATE	MAT'L	TITLE	SWITCH
Jack Lu	12/27/22		MODLE	TACT SWITCH WITH LED
CHECKED BY:	DATE	FINISH	DWG NO.	SIZE
Jacky Chen	12/27/22		PART NO.	A4
APPROVED BY:	DATE	SCALE	1 : 1	VER
Tony Kao	12/27/22	SHEET NO.	1 of 1	R