

Switch Specifications

| | |
|---------------------------------|---|
| Circuit | :SPST |
| Current rating | :50mA |
| Voltage rating | :12VDC |
| Dielectric withstanding voltage | :250VAC for 1 minute |
| Contact resistance | :30mΩ Max. (Initial) |
| Insulation resistance | :100MΩ Min. |
| Operating force | :250±50gf |
| | :180±50gf |
| Total travel | :0.25mm±0.1mm |
| Operating life | :100,000 cycles Min |
| Solder specifications | :260° C for 5 seconds |
| Function | :Momentary |
| Operating temperature | :-20° C ~ +70° C |
| Welding method | :Manual Soldering (350° C±5° C, 3s±0.5s) |
| | :Reflow soldering |

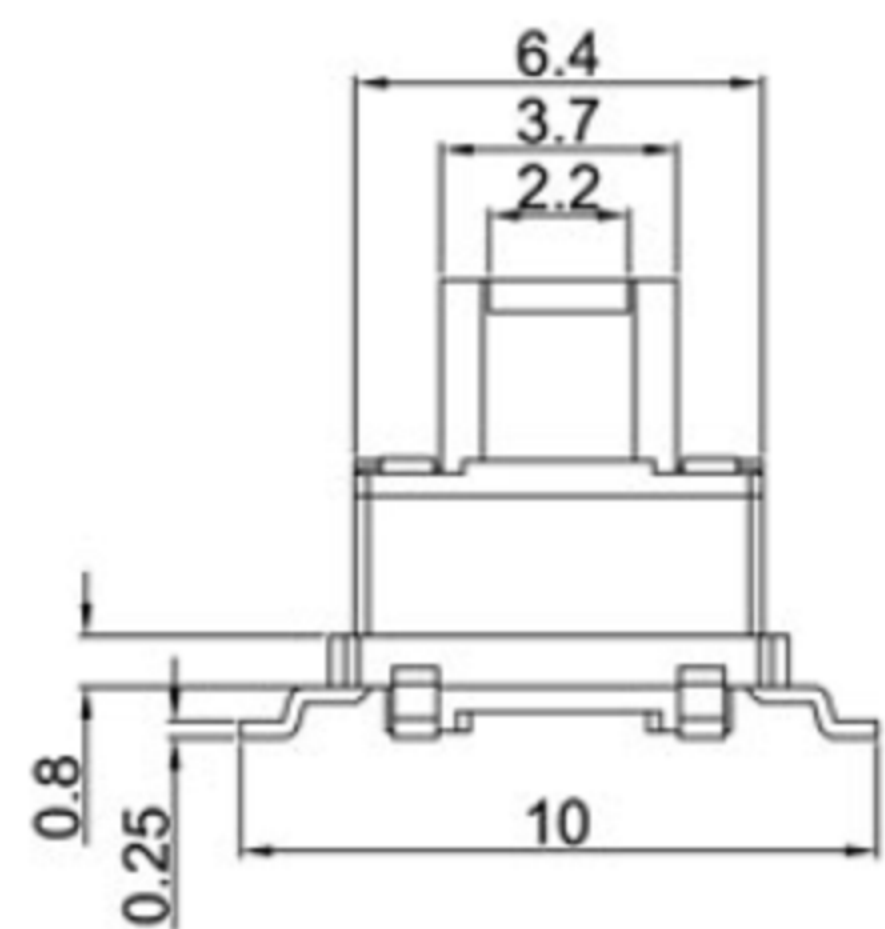

P.C.B. LAYOUT

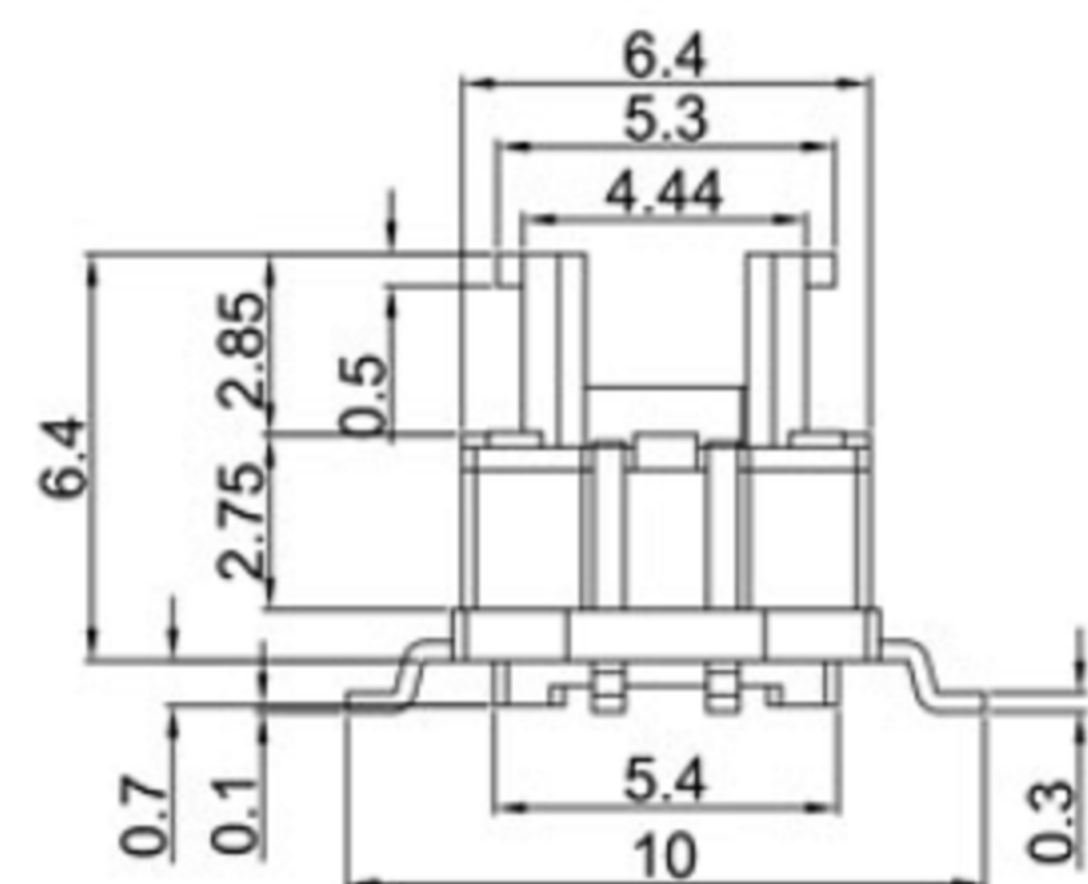
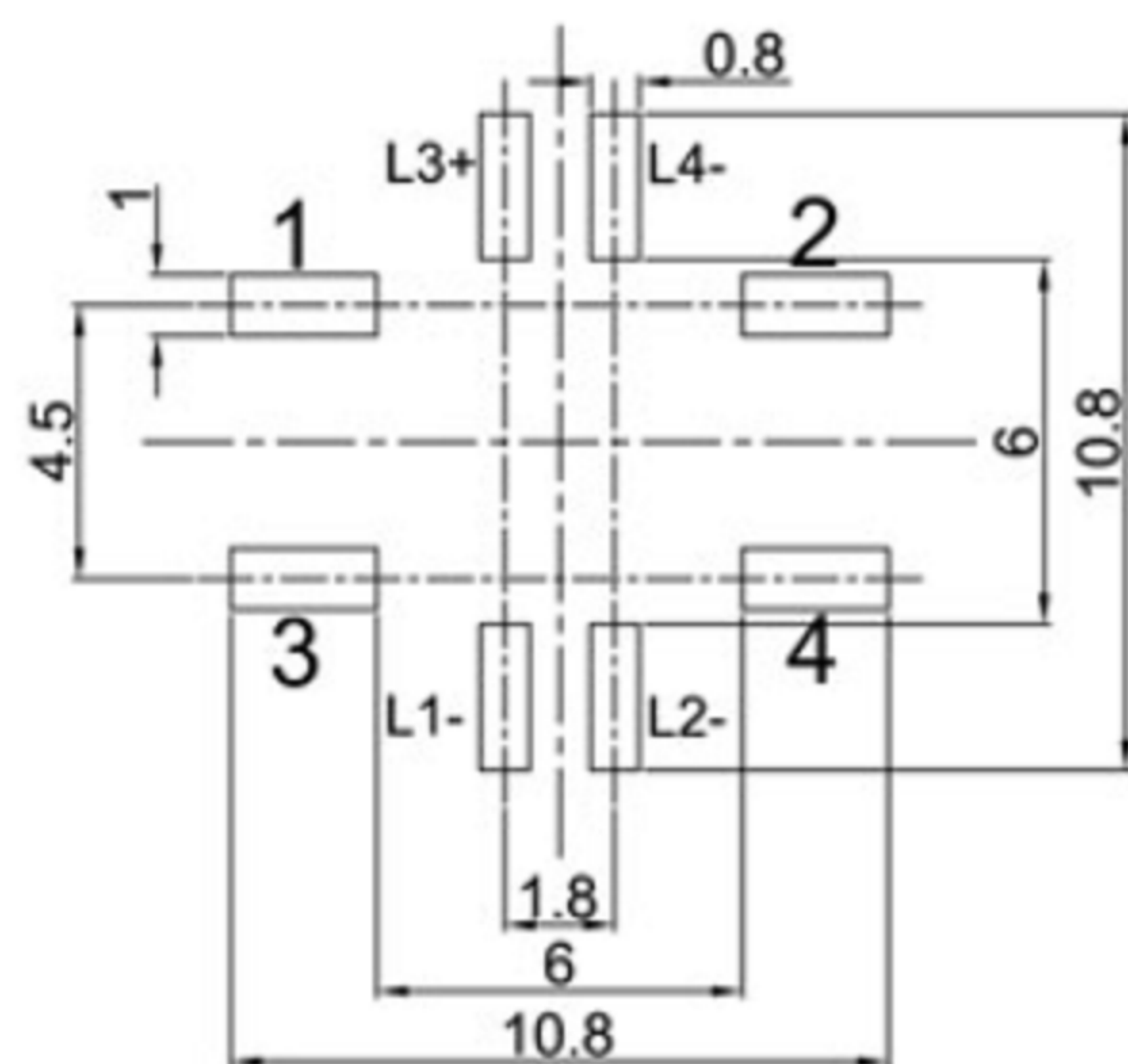

CIRCUIT

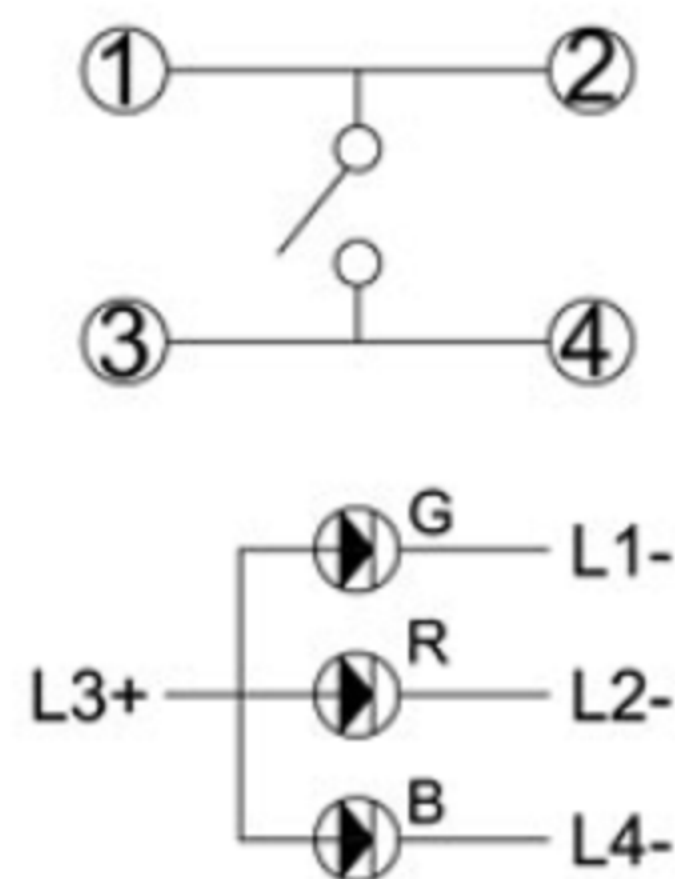

| NO. | DESCRIPTION | QTY | MATERIAL | PLATING |
|-----|-------------|-----|-----------------|-------------|
| 7 | CAP | 1 | ABS / PC | Black |
| 6 | LED | 1 | | |
| 5 | FIXITY | 1 | PA66 | Black |
| 4 | CONTACT | 1 | PHOSPHOR BRONZE | Ag plated |
| 3 | TERMINAL | 2 | BRASS | Ag plated |
| 2 | CASE | 1 | PA66 | Black |
| 1 | KNOB | 1 | PA66 | Black/White |

广东科斯达电子科技有限公司
GUANG DONG KE SI DA ELECTRONIC TECHNOLOGY CO., LTD.

TOLERANCE UNLESS OTHERWISE STATED:
 Up to 5 ±0.2
 Above 5 ~ 15 ±0.3
 Above 15 ~ 30 ±0.4
 Above 30 ~ 50 ±0.5
 Angle ±0.3

3RD. ANGEL'S

UNITS MM

| | | | | |
|--------------|----------|-----------|----------|----------------------|
| DRAWN BY: | DATE | MAT'L | TITLE | SWITCH |
| Jack Lu | 12/27/22 | | MODLE | TACT SWITCH WITH LED |
| CHECKED BY: | DATE | FINISH | DWG NO. | SIZE |
| Jacky Chen | 12/27/22 | | | A4 |
| APPROVED BY: | DATE | SCALE | PART NO. | VER |
| Tony Kao | 12/27/22 | 1:1 | | R |
| | | SHEET NO. | | |
| | | 1 of 1 | | |

| ITEM NO. | DESCRIPTION | DRAWN | DATE |
|----------|-------------|-------|------|
| | | | |