

P.C.B. LAYOUT

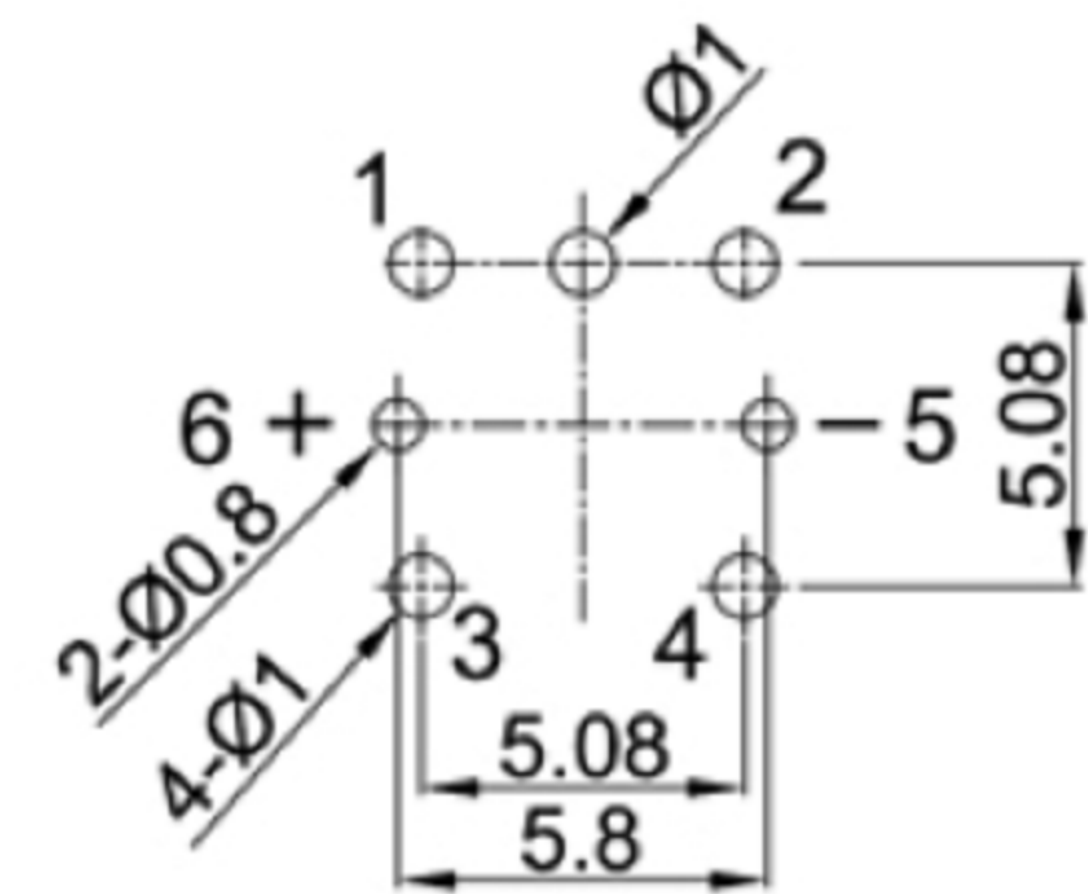

CIRCUIT

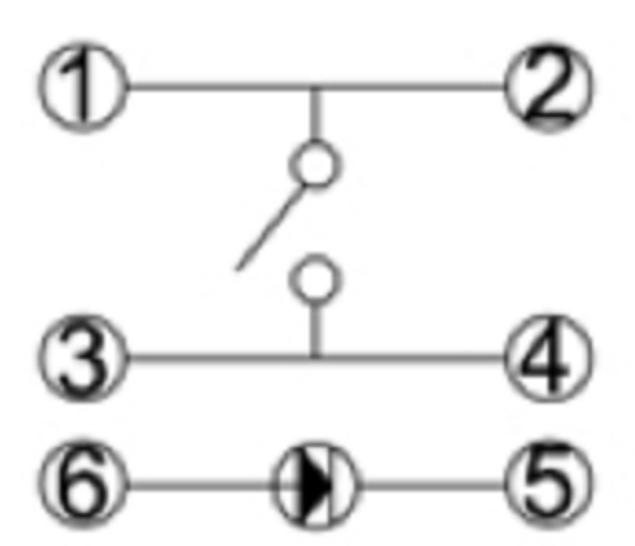

Switch Specifications

Circuit	:SPST
Current rating	:50mA
Voltage rating	:12VDC
Dielectric withstanding voltage	:250VAC for 1 minute
Contact resistance	:30mΩ Max. (Initial)
Insulation resistance	:100MΩ Min.
Operating force	:180±50gf
Total travel	:0.25mm±0.1mm
Operating life	:100,000 cycles Min
Solder specifications	:260° C for 5 seconds
Function	:Momentary
Operating temperature	:-20° C ~ +70° C
Welding method	:Manual Soldering 350° C±5° C, 3s±0.5s

W1	白色	2.8	3.3	3.8	25	100	XY	XY
U1	蓝色	2.8	3.2	3.8	25	100	460	463
G5	绿色	2.8	3.2	3.6	25	100	521	520
Y1	黄色	1.6	2.0	2.6	25	100	590	590
R5	红色	1.6	2.0	2.6	25	100	625	620
灯发光颜色 X Emitted color X		最小	一般	最大	最大操作电流 (mA)	最大脉冲电流 (mA)	主波长 (nm)	峰值波长 (nm)
		顺向电压(V)						

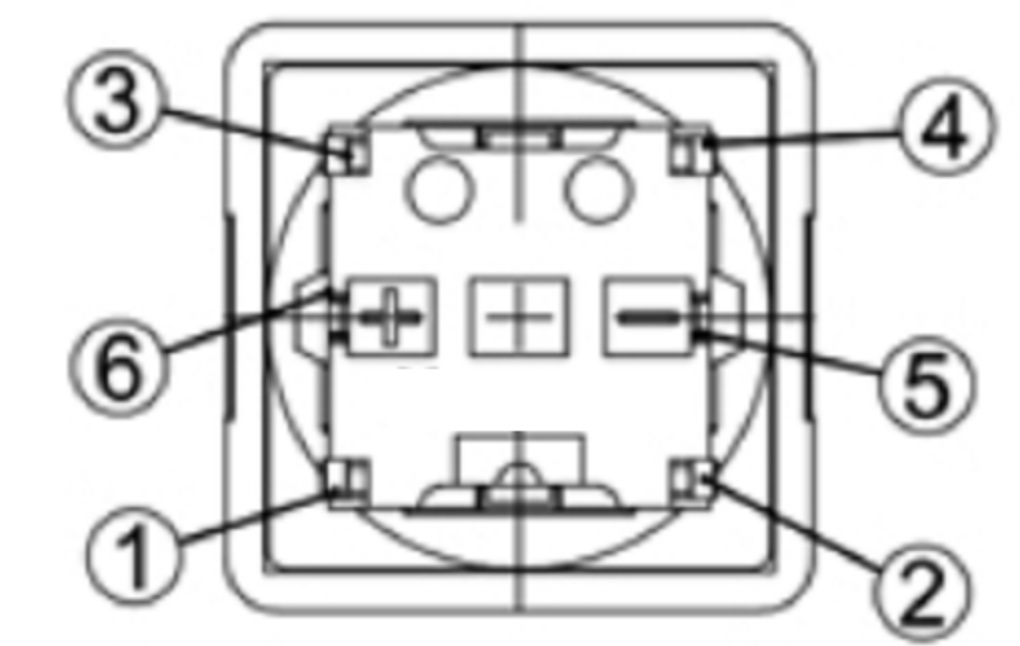
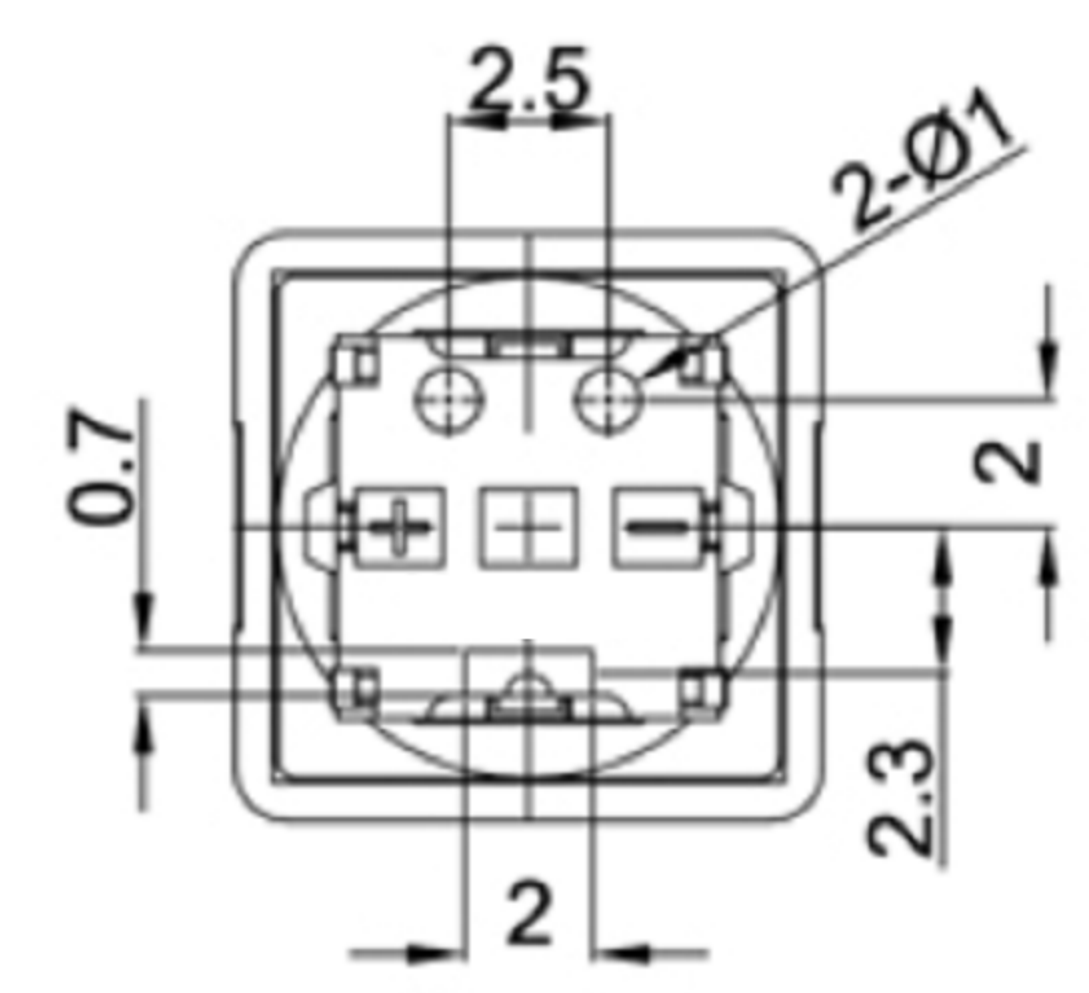
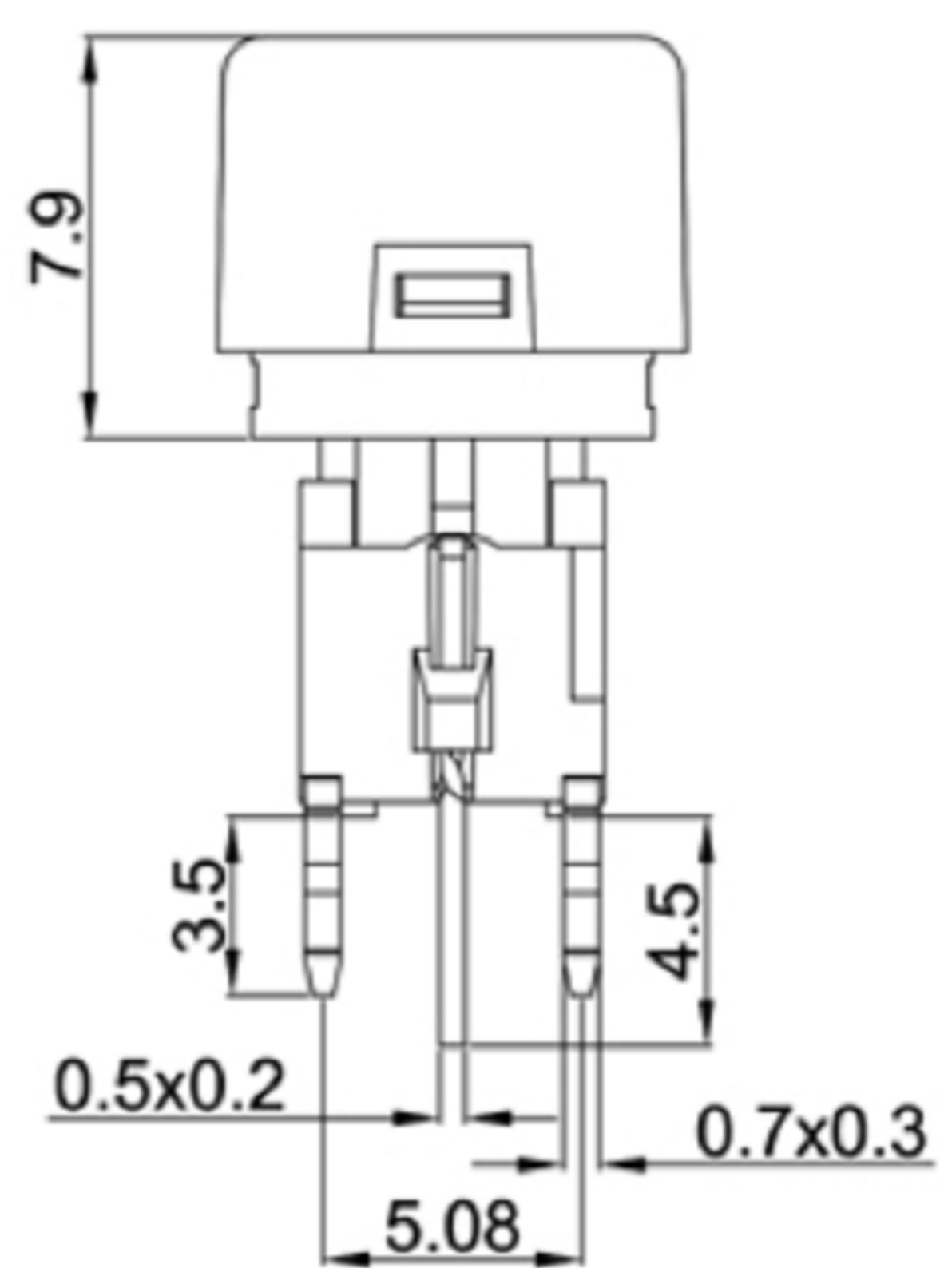
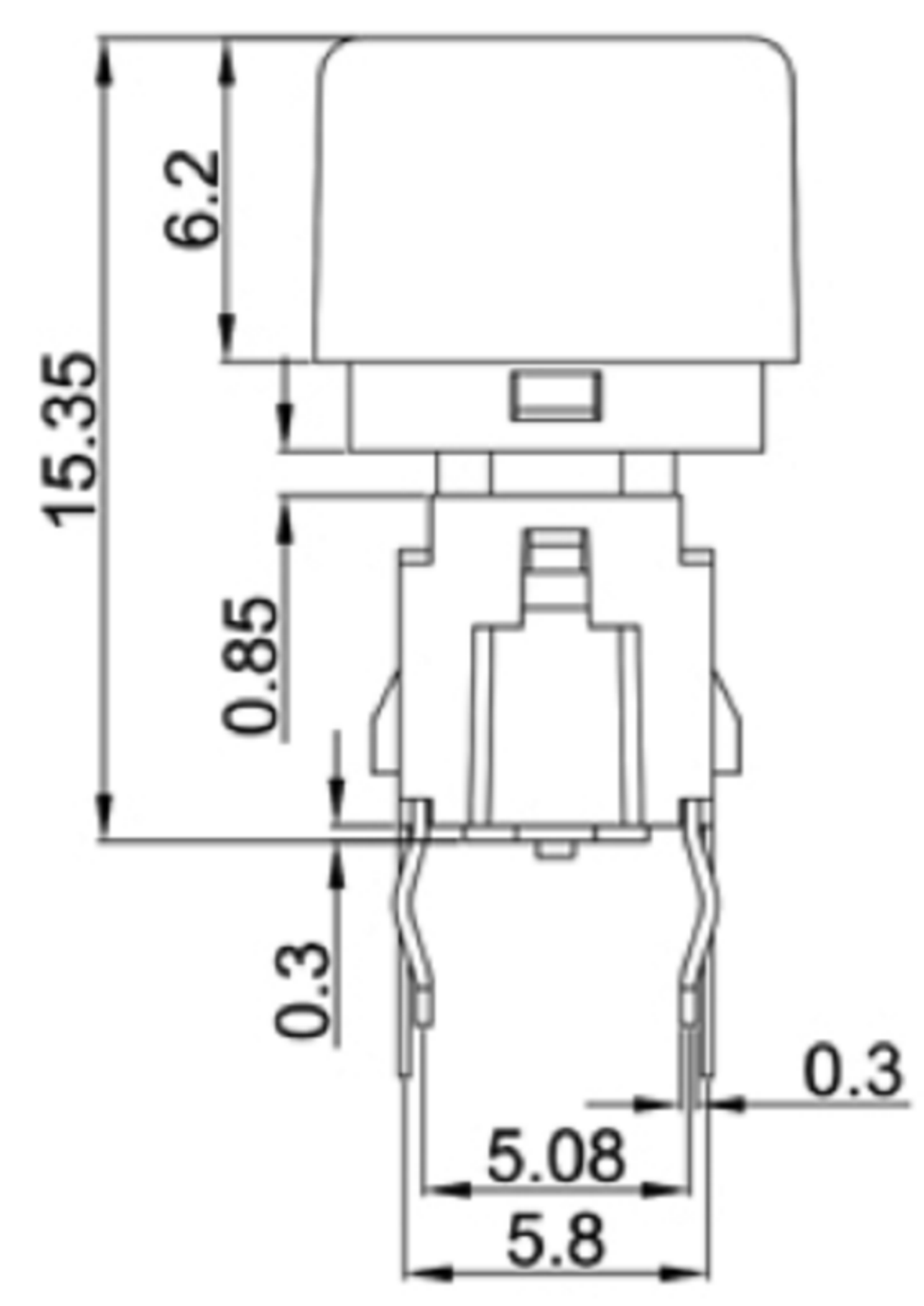

7	CAP	1	ABS / PC	Black
6	LED	1		
5	FIXITY	1	PA66	Black
4	CONTACT	1	PHOSPHOR BRONZE	Ag plated
3	TERMINAL	2	BRASS	Ag plated
2	CASE	1	PA66	Black
1	KNOB	1	PA66	Black/White
NO.	DESCRIPTION	QTY	MATERIAL	PLATING

广东科斯达电子科技有限公司
GUANG DONG KE SI DA ELECTRONIC TECHNOLOGY CO., LTD.

TOLERANCE UNLESS OTHERWISE STATED:
Up to 5 ±0.2
Above 5 ~ 15 ±0.3
Above 15 ~ 30 ±0.4
Above 30 ~ 50 ±0.5
Angle ±0.3

3RD. ANGEL'S

UNITS MM

DRAWN BY:	DATE	MAT'L	TITLE	SWITCH
Jack Lu	12/27/22		MODLE	TACT SWITCH WITH LED
CHECKED BY:	DATE	FINISH	SCALE	1:1
Jacky Chen	12/27/22		DWG NO.	
APPROVED BY:	DATE	SHEET NO.	PART NO.	
Tony Kao	12/27/22	1 of 1		

ITEM NO.	DESCRIPTION	DRAWN	DATE