

**SPECIFICATIONS**

Circuit	:SPDT/DPDT
Current rating	:0.2A/1A/3A
Voltage rating	:250VAC
Dielectric withstanding voltage	:1000VAC for 1 minute
Contact resistance	:50mΩ Max.
Insulation resistance	:100MΩ Min.
Travel	:2.8mm±0.5mm
Operating Force	:700±200gf
Mechanical life	:250,000 cycles Min
Electric life	:50,000 cycles Min
Solder specifications	:260°C for 5 seconds
Function	:OFF-ON
Operating temperature	:-30°C ~ +70°C

Internal O-Ring to be coated with Low Temp Synthetize Grease.  
Sealing: Back-IP65.

**MATERIAL:**

- Base: SUS;
- Button: Al alloy ;
- Terminal: Brass, Golden plated ;
- Nut: Brass, Without Surface Plated .

**Panel Mounting**

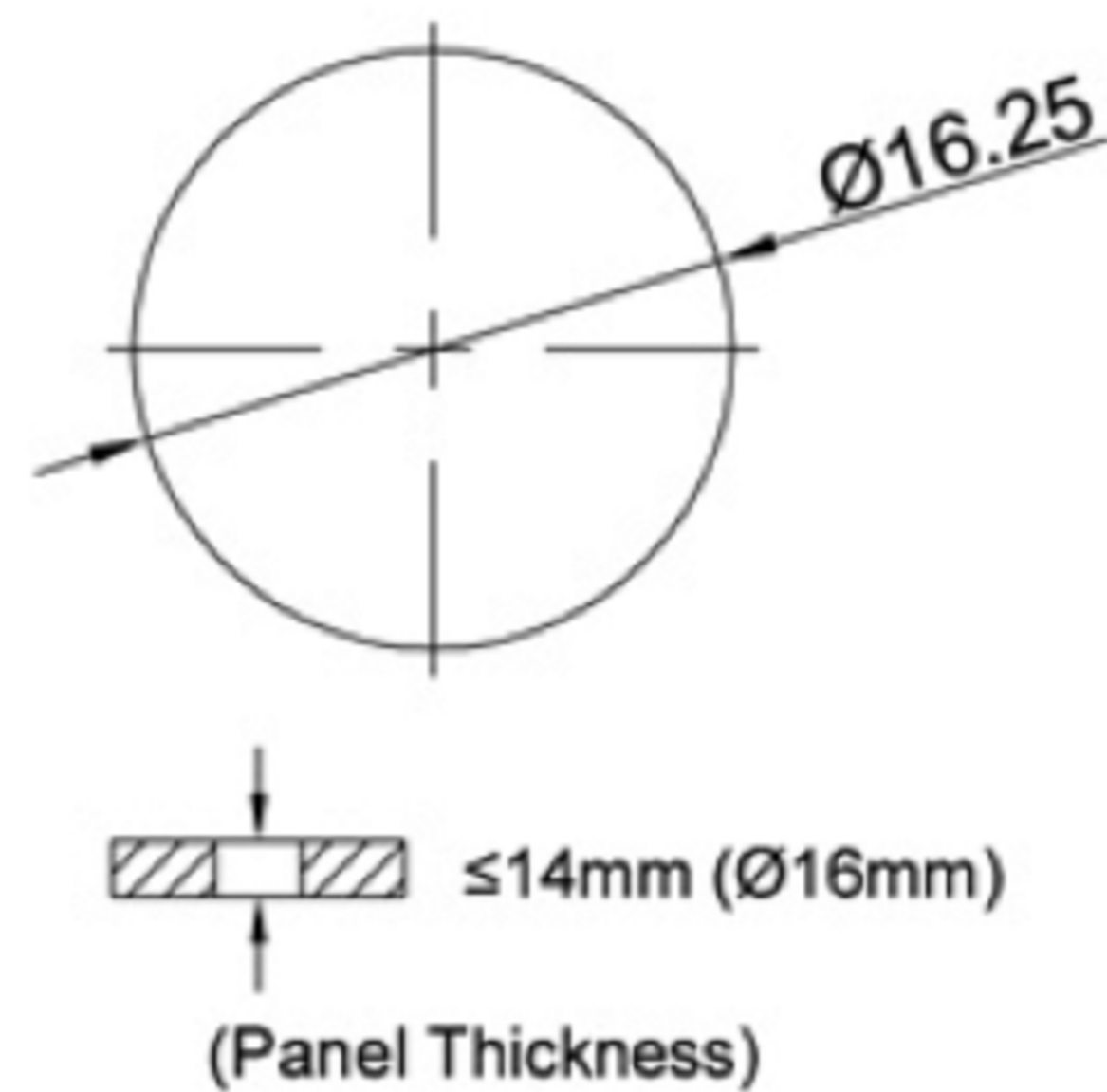

**Circuit Diagram**

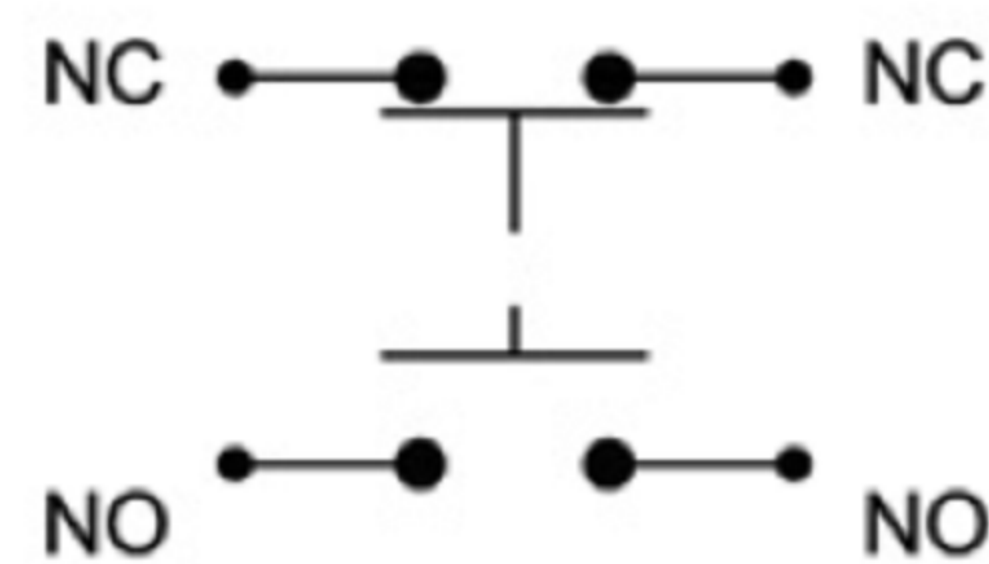

 **广东科斯达电子科技有限公司**  
GUANG DONG KE SI DA ELECTRONIC TECHNOLOGY CO., LTD.

TOLERANCE UNLESS OTHERWISE STATED :  
Up to 5 ±0.2  
Above 5 ~ 15 ±0.3  
Above 15 ~ 30 ±0.4  
Above 30 ~ 50 ±0.5  
Angle ±0.3

3RD. ANGEL'S

UNITS MM

DRAWN BY:	DATE	MAT'L	TITLE	SWITCH
Jack Lu	12/27/22			
CHECKED BY:	DATE	FINISH	MODLE	TACT SWITCH WITH LED
Jacky Chen	12/27/22			
APPROVED BY:	DATE	SCALE	DWG NO.	
Tony Kao	12/27/22	1 : 1		
		SHEET NO.	PART NO.	
		1 of 1		

ITEM NO.	DESCRIPTION	DRAWN	DATE