

Switch Specifications

Circuit	:SPST
Current rating	:50mA
Voltage rating	:12VDC
Dielectric withstanding voltage	:250VAC for 1 minute
Contact resistance	:30mΩ Max. (Initial)
Insulation resistance	:100MΩ Min.
Operating force	:180±50gf
Total travel	:0.25mm±0.1mm
Operating life	:100,000 cycles Min
Solder specifications	:256°C for 5 seconds
Function	:Momentary
Operating temperature	:-20°C ~ +70°C
Welding method	:Manual Soldering (350°C±5°C, 3s±0.5s)

P.C.B. LAYOUT

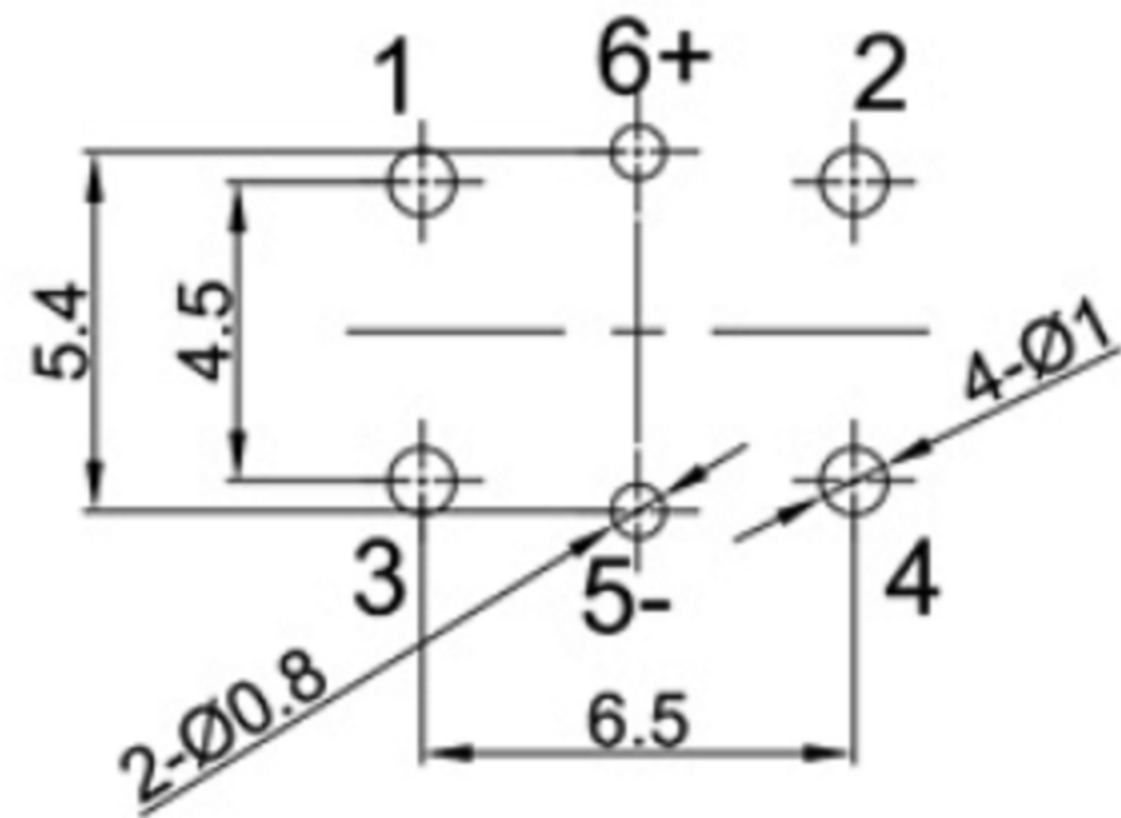

CIRCUIT

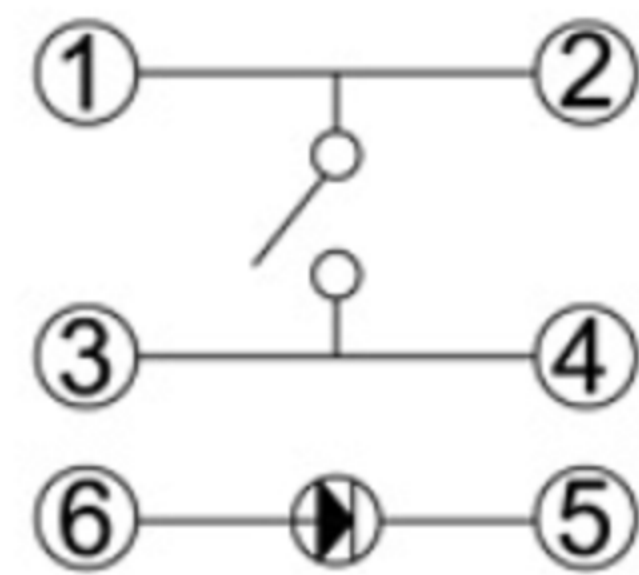

LED Specifications

W	白色	2.8	3.4	3.8	20
O	橙色	1.8	2.2	2.4	20
RU	蓝色	2.8	3.2	3.4	20
	红色	1.8	2.2	2.4	20
U	蓝色	2.8	3.2	3.4	20
G	黄绿色	1.8	2.2	2.4	20
Y	黄色	1.8	2.2	2.4	20
R	红色	1.8	2.2	2.4	20
灯发光颜色 X Emitted color X		最小	一般	最大	最大操作电流 (mA)
		顺向电压(V)			

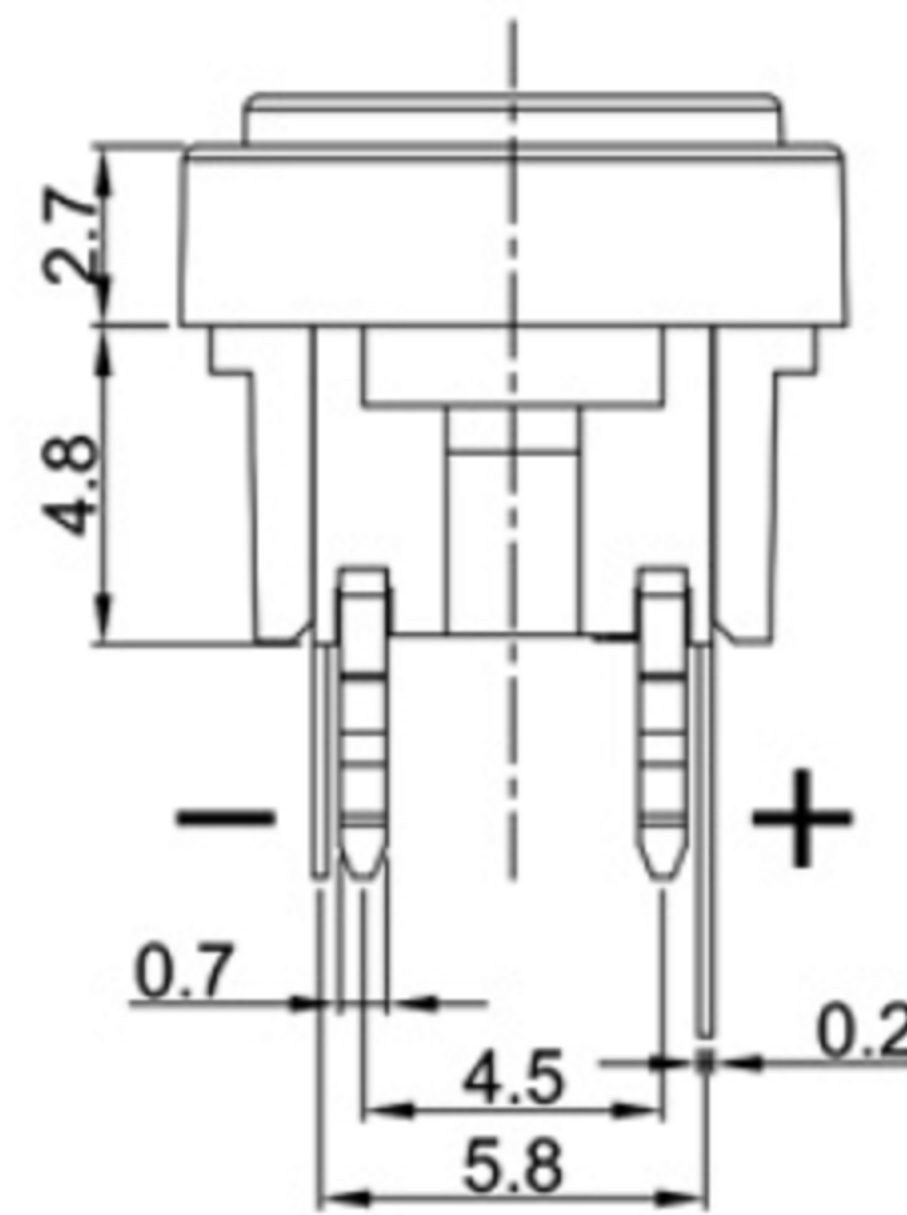
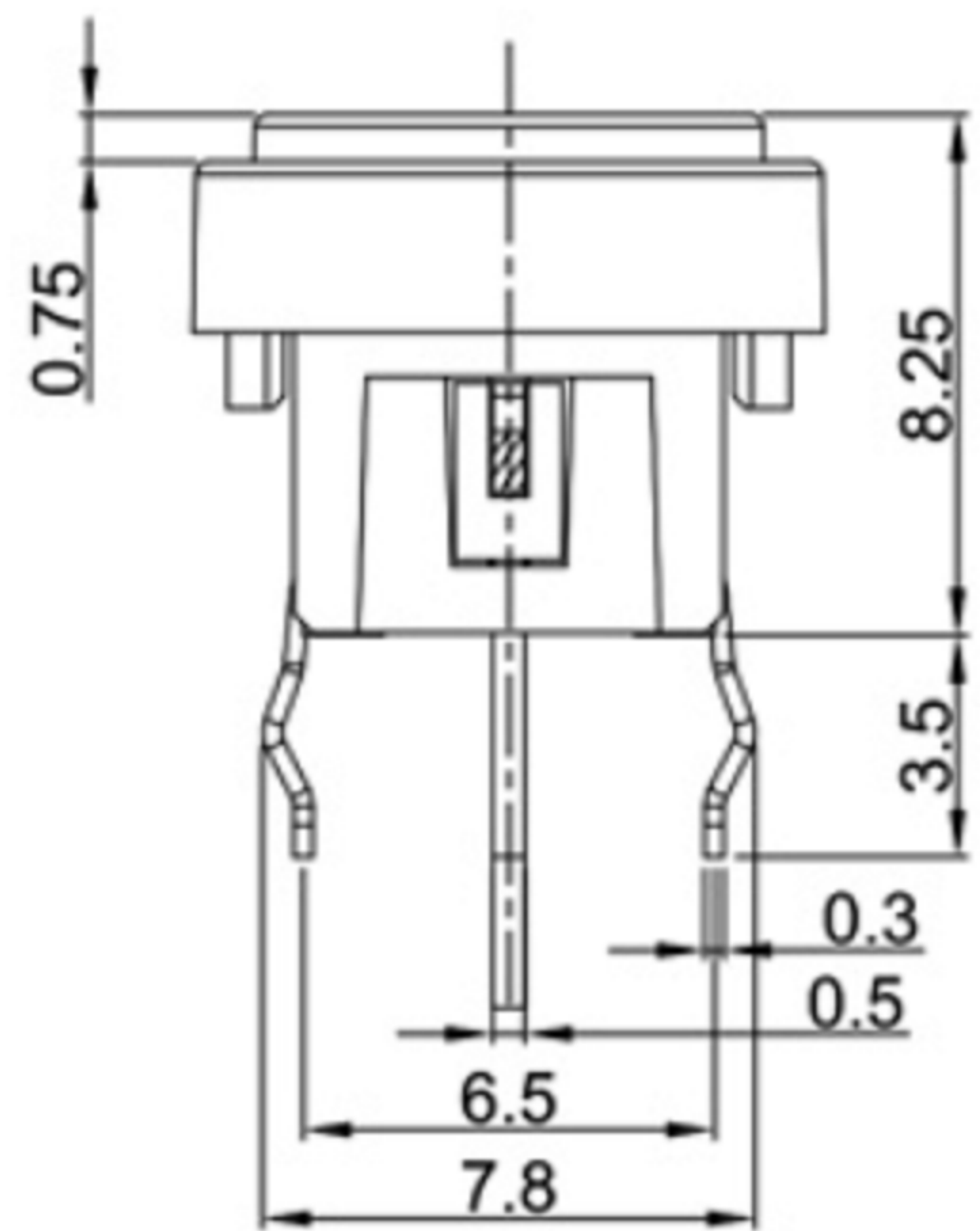

NO.	DESCRIPTION	QTY	MATERIAL	PLATING
7	CAP	1	ABS / PC	Black
6	LED	1		
5	FIXITY	1	PA66	Black
4	CONTACT	1	PHOSPHOR BRONZE	Ag plated
3	TERMINAL	2	BRASS	Ag plated
2	CASE	1	PA66	Black
1	KNOB	1	PA66	Black/White

广东科斯达电子科技有限公司
GUANG DONG KE SI DA ELECTRONIC TECHNOLOGY CO., LTD.

TOLERANCE UNLESS OTHERWISE STATED:
Up to 5 ±0.2
Above 5 ~ 15 ±0.3
Above 15 ~ 30 ±0.4
Above 30 ~ 50 ±0.5
Angle ±0.3

3RD. ANGEL'S

UNITS MM

DRAWN BY:	DATE	MAT'L	TITLE	SWITCH
Jack Lu	12/27/22		MODLE	TACT SWITCH WITH LED
CHECKED BY:	DATE	FINISH	DWG NO.	SIZE
Jacky Chen	12/27/22			A4
APPROVED BY:	DATE	SCALE	PART NO.	VER
Tony Kao	12/27/22	1:1		R
		SHEET NO.		
		1 of 1		