

Switch Specifications

Rating: 5A 250VAC ;
2A 36VDC ;

Degree of protection: IP67 ;
Contact Resistance: 50mΩ Max. ;
Dielectric Strength: 1000VAC For 1 minute ;
Total Travel: 2.8±0.5mm ;
Operating Force: 600±200gf ;
Mechanical Life: 200,000 cycles ;
Load Life: 50,000 cycles ;
Operating Temperature: -20° C ~ 85° C ;
Function: OFF-(ON)

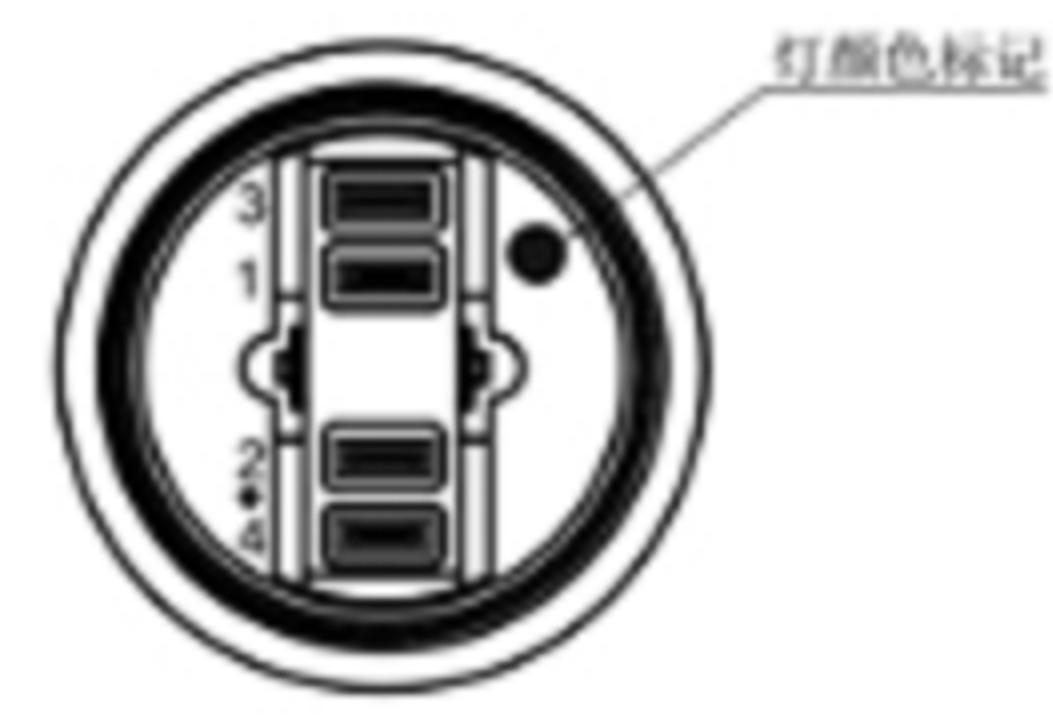
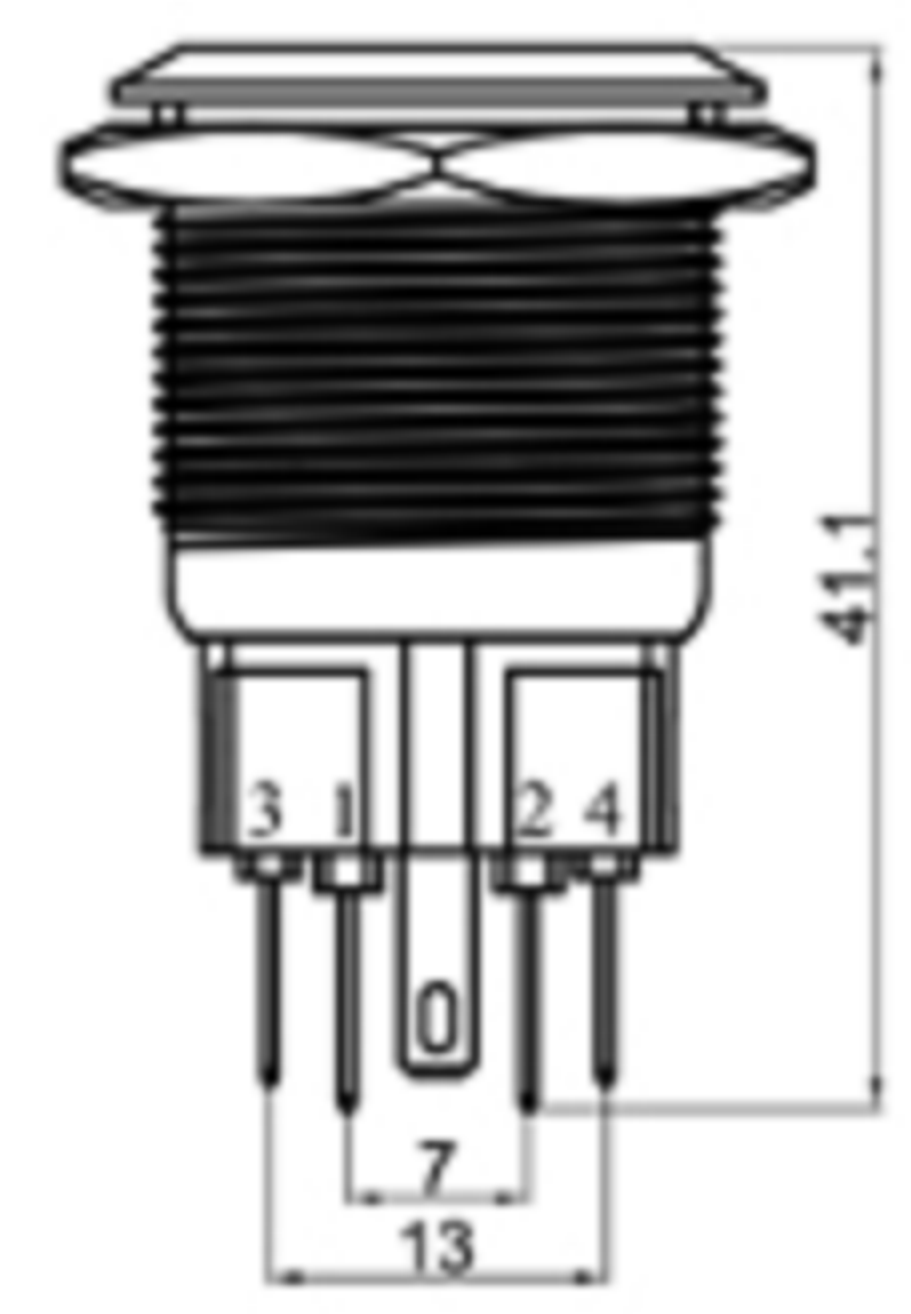
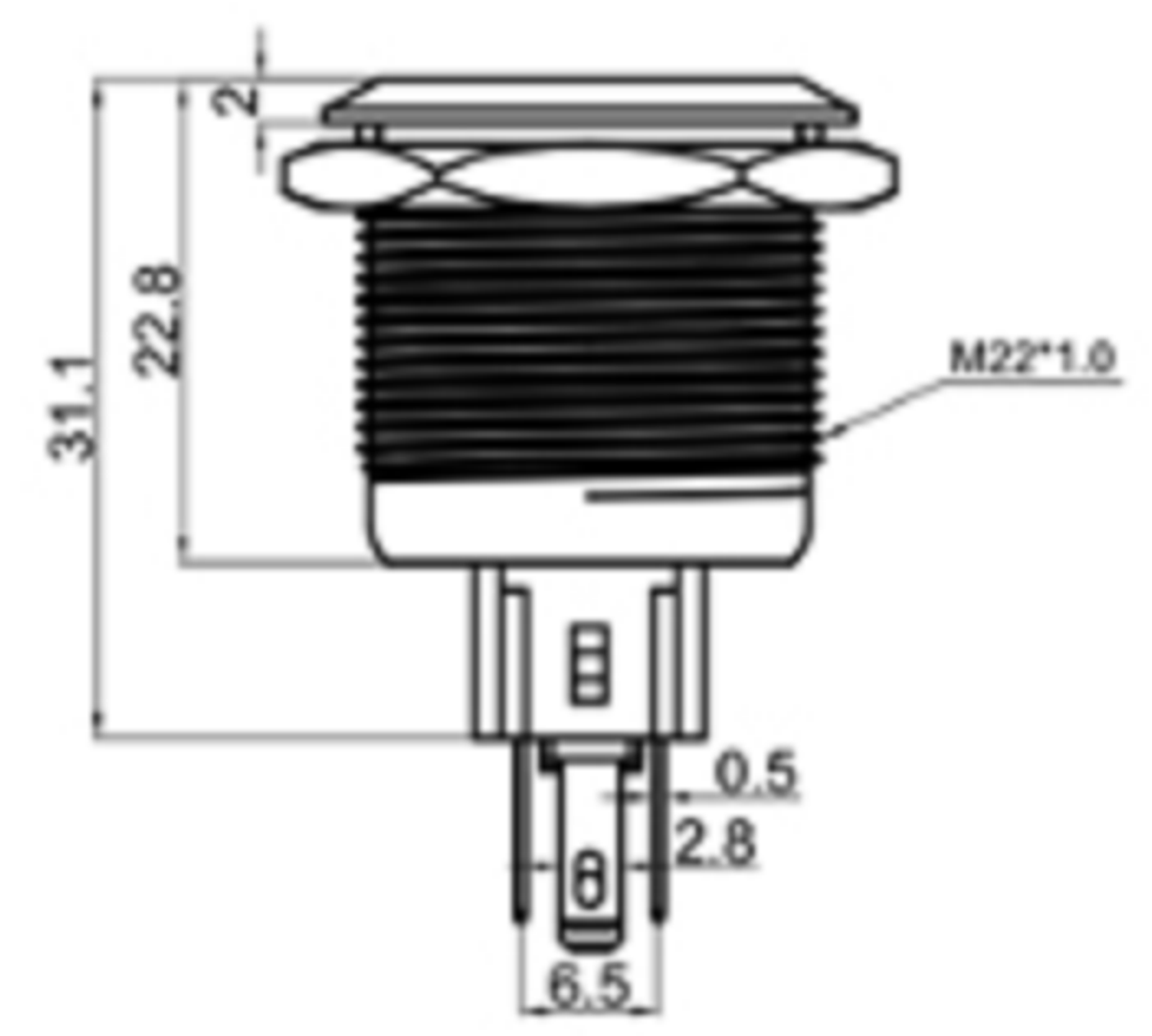

Panel Thickness: 10mm MAX.

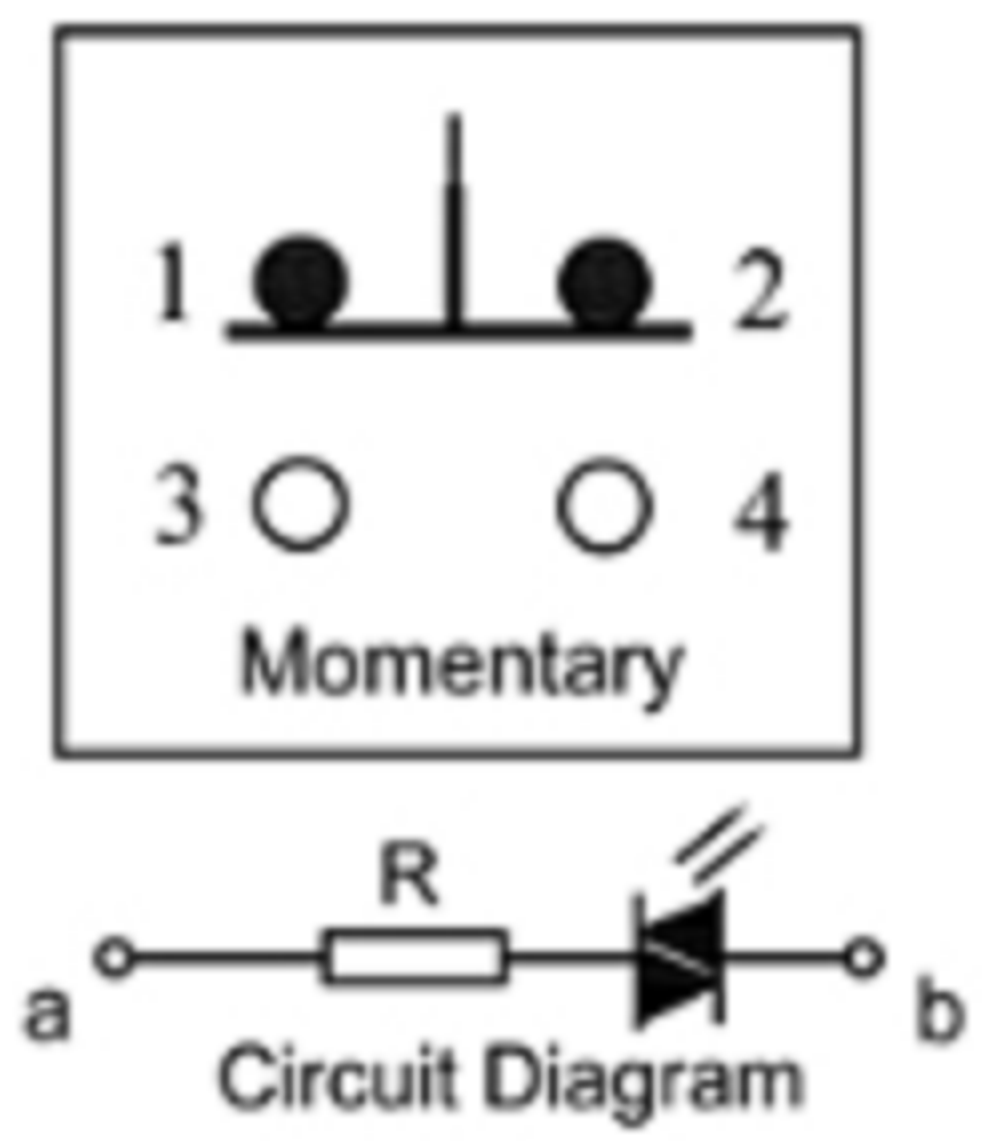

广东科斯达电子科技有限公司
GUANG DONG KE SI DA ELECTRONIC TECHNOLOGY CO., LTD.

TOLERANCE UNLESS OTHERWISE STATED:
Up to 5 ±0.2
Above 5 ~ 15 ±0.3
Above 15 ~ 30 ±0.4
Above 30 ~ 50 ±0.5
Angle ±0.3

3RD. ANGEL'S

UNITS MM

| | | | | |
|--------------|----------|-----------|----------|----------------------|
| DRAWN BY: | DATE | MAT'L | TITLE | SWITCH |
| Jack Lu | 12/27/22 | | MODLE | TACT SWITCH WITH LED |
| CHECKED BY: | DATE | FINISH | SCALE | 1 : 1 |
| Jacky Chen | 12/27/22 | | DWG NO. | |
| APPROVED BY: | DATE | SHEET NO. | PART NO. | |
| Tony Kao | 12/27/22 | 1 of 1 | | |

| | | | |
|----------|-------------|-------|------|
| ITEM NO. | DESCRIPTION | DRAWN | DATE |
| | | | |

SIZE
A4
VER
R