

Rating: 12A 125VAC
 10A 250VAC(CQC / ENEC/CB)
 Contact Resistance: 50mΩ max
 Insulation Resistance: DC 500V 100MΩ min.
 Dielectric Strength: AC 1500V 1 minute
 Operating Force: 300±100gf
 Mechanical Life: Over 30,000 cycles
 Electrical Life: Over 10,000 cycles
 Operating Temperature: 0°C ~ 85°C
 Safety Approval:

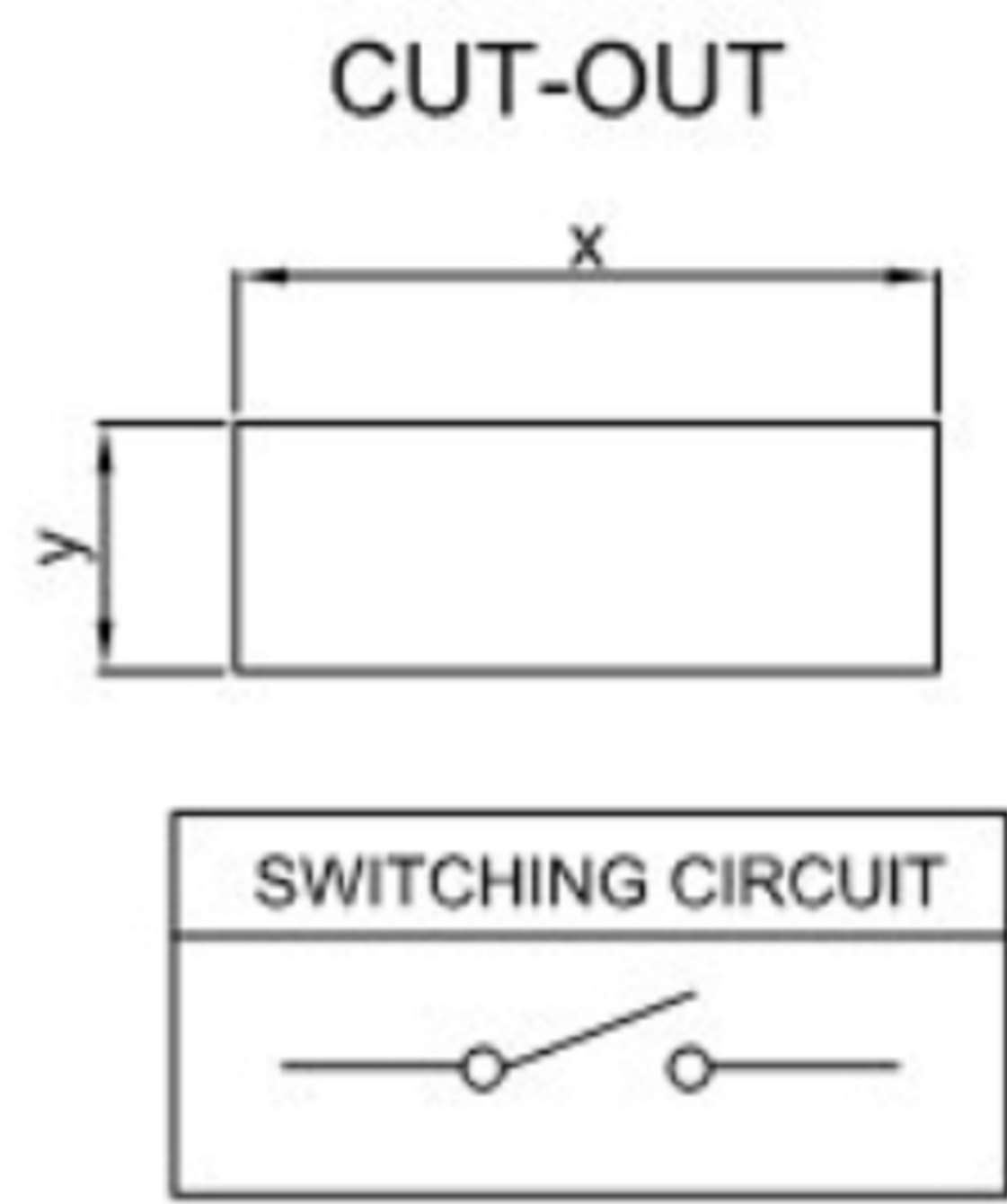
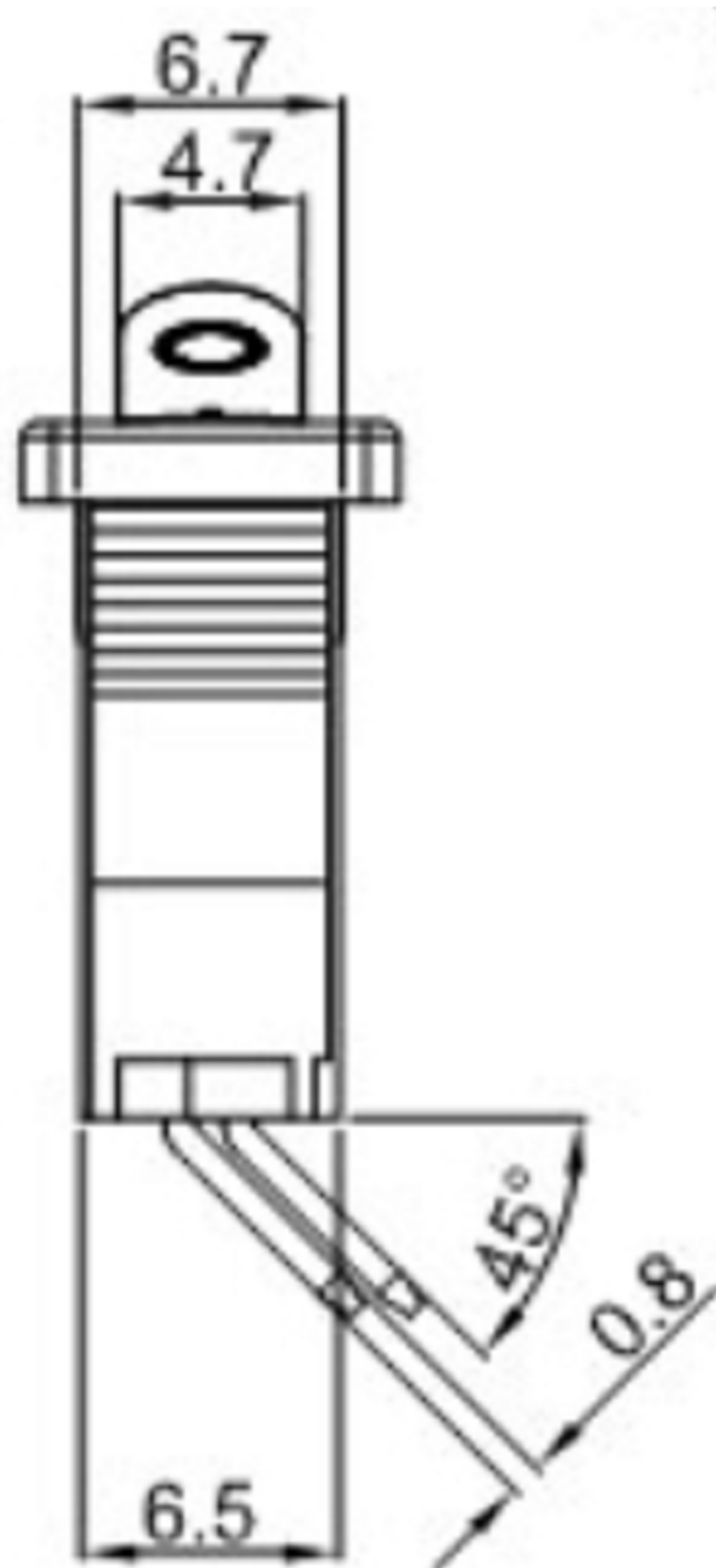
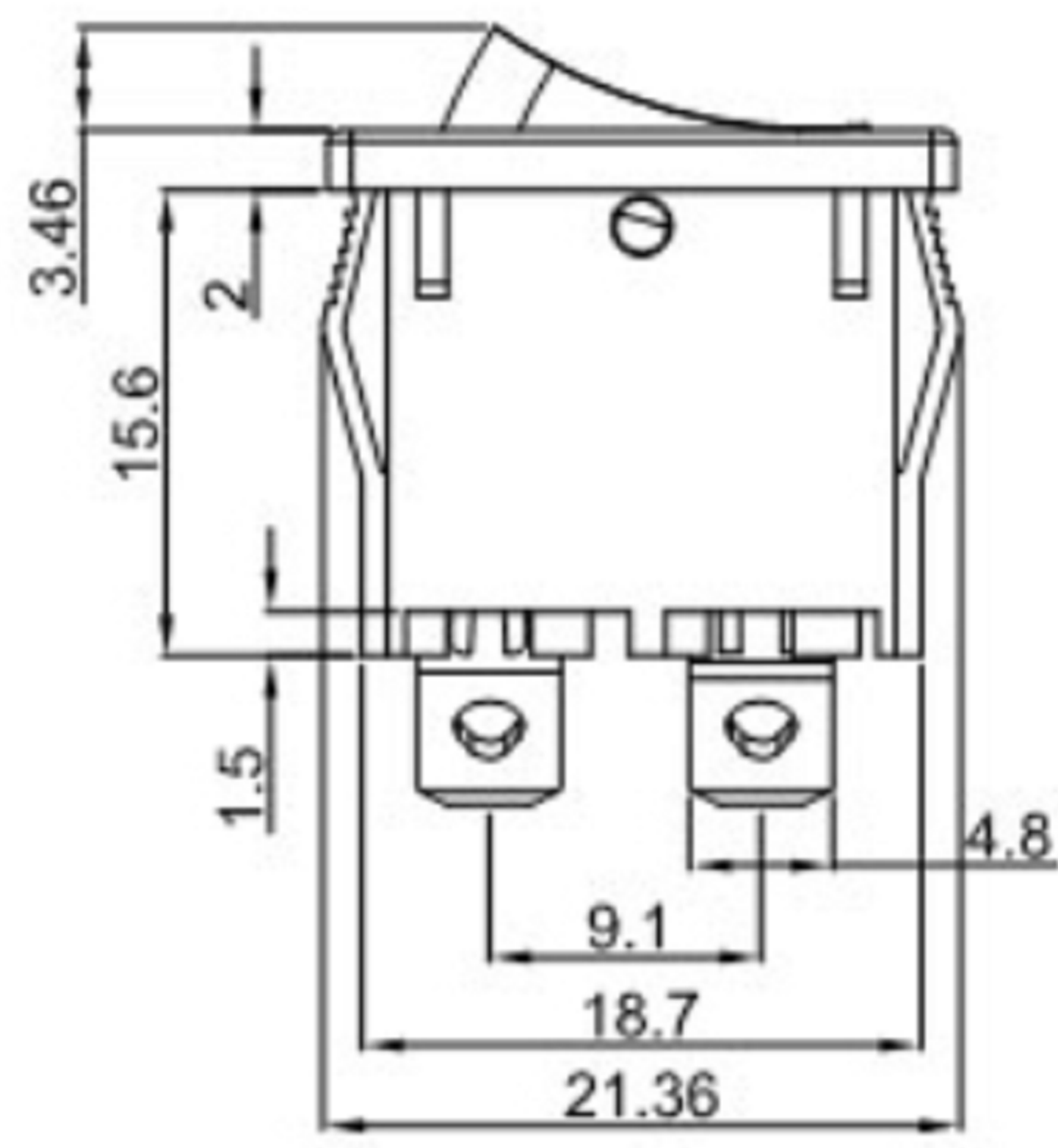

	X	Y
0.75~1.25	19.2±0.1	6.8-0.1
1.25~2.00	19.4±0.1	6.8-0.1
2.00~3.00	19.8±0.1	6.8-0.1

广东科斯达电子科技有限公司
 GUANG DONG KE SI DA ELECTRONIC TECHNOLOGY CO., LTD.

TOLERANCE UNLESS OTHERWISE STATED: Up to 5 ±0.2, Above 5 ~ 15 ±0.3, Above 15 ~ 30 ±0.4, Above 30 ~ 50 ±0.5, Angle ±0.3
 3RD. ANGEL'S UNITS MM

DRAWN BY:	DATE	MAT'L	TITLE	SWITCH
Jack Lu	12/27/22			
CHECKED BY:	DATE	FINISH	MODLE	TACT SWITCH WITH LED
Jacky Chen	12/27/22			
APPROVED BY:	DATE	SCALE	DWG NO.	SIZE
Tony Kao	12/27/22	1:1		A4
		SHEET NO.	PART NO.	VER
		1 of 1		R