



Unit: mm

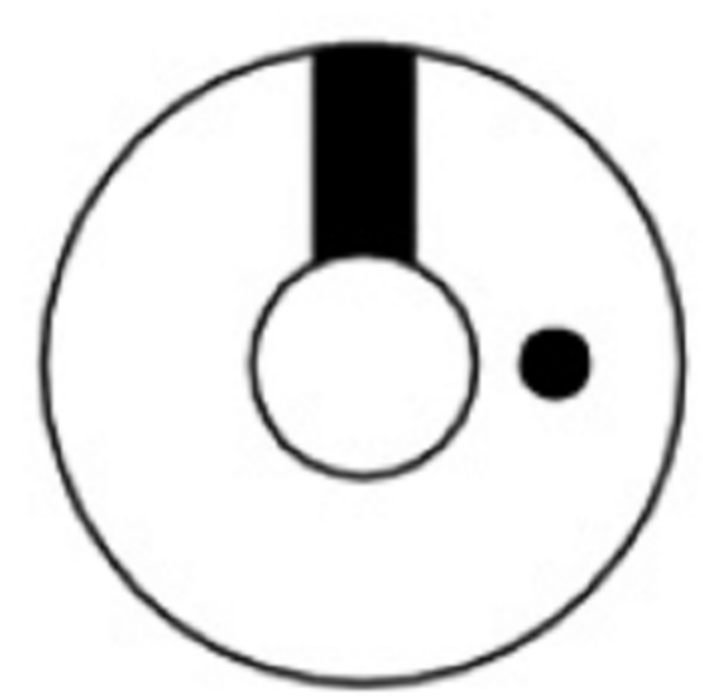
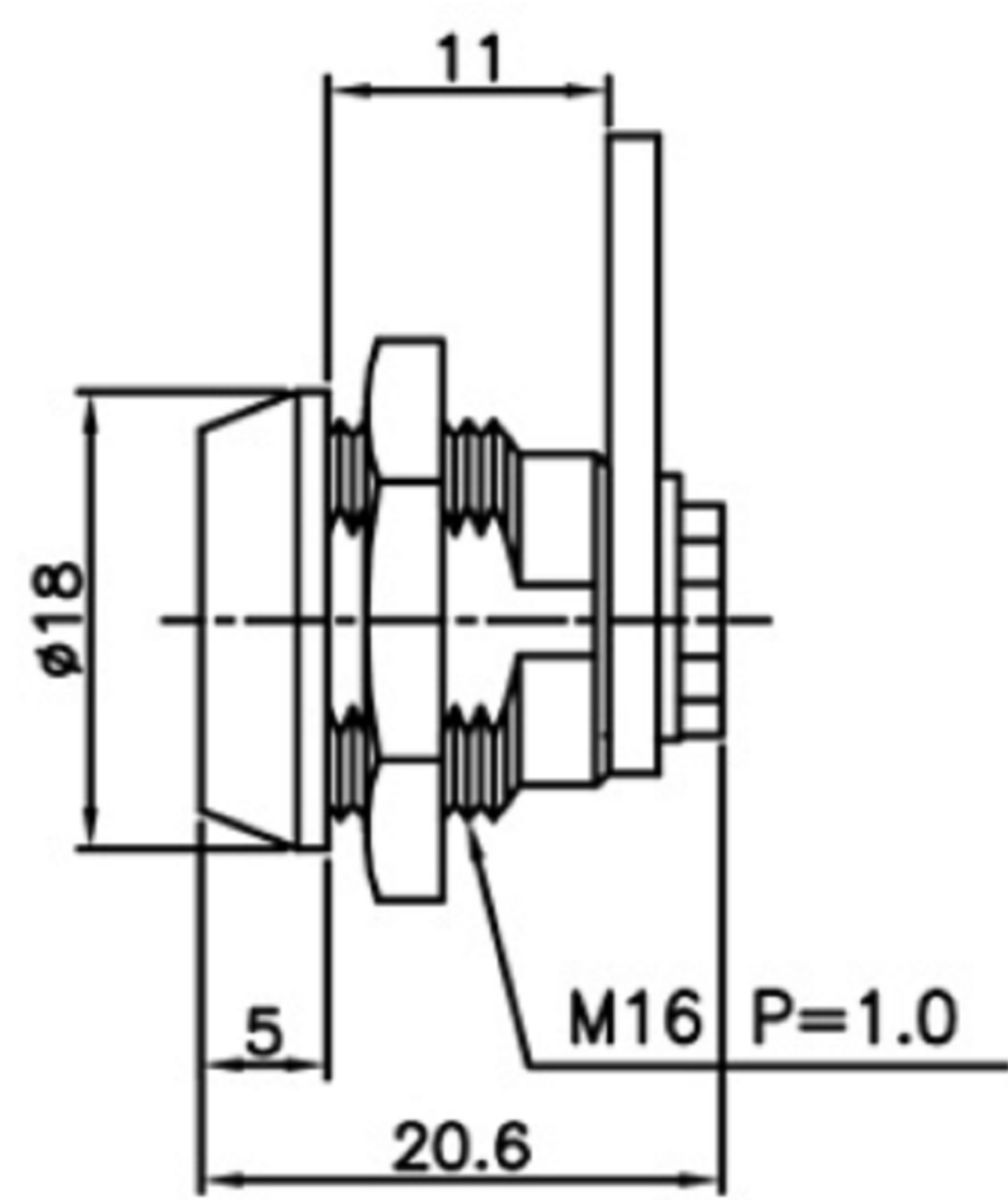
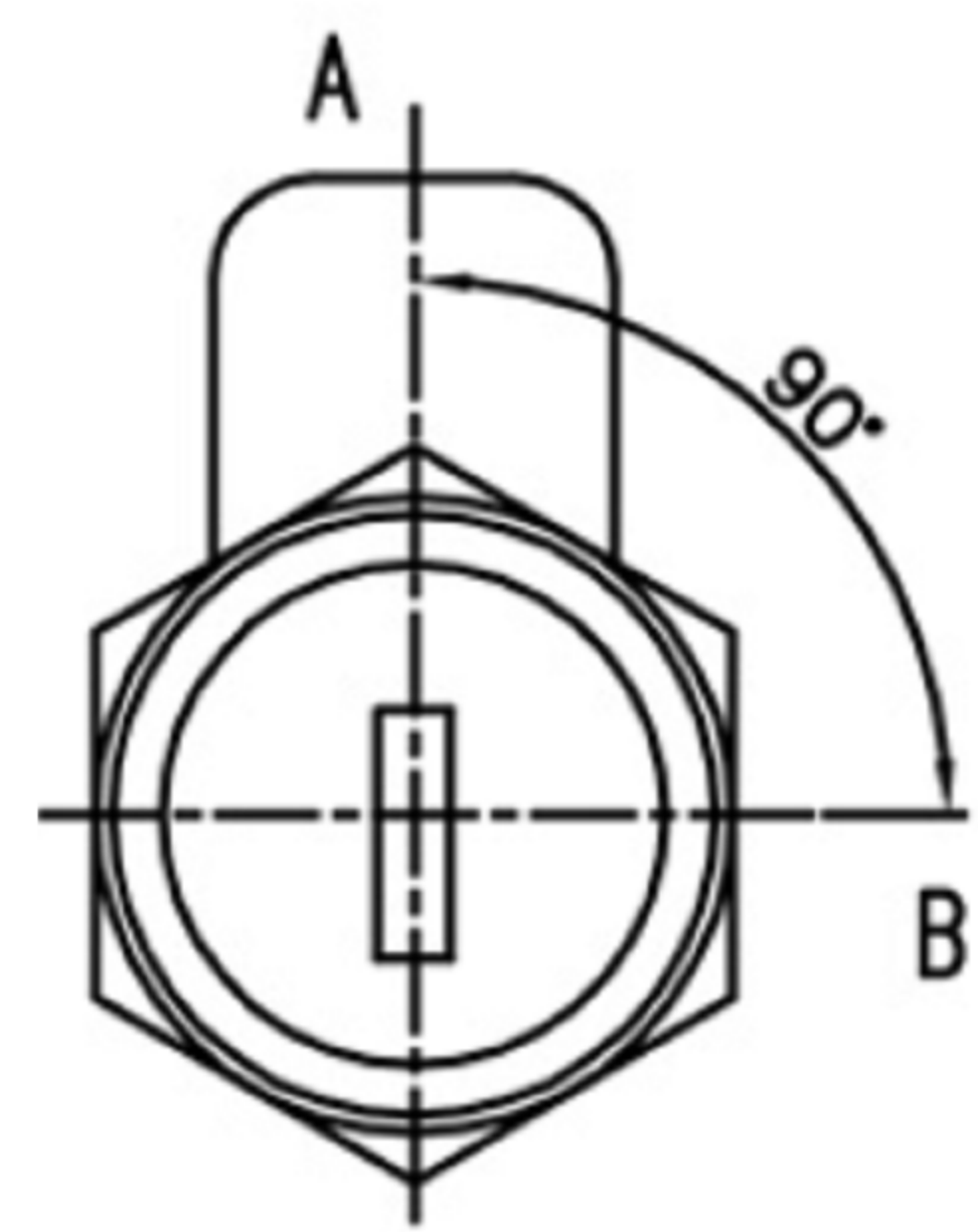

Fig.1

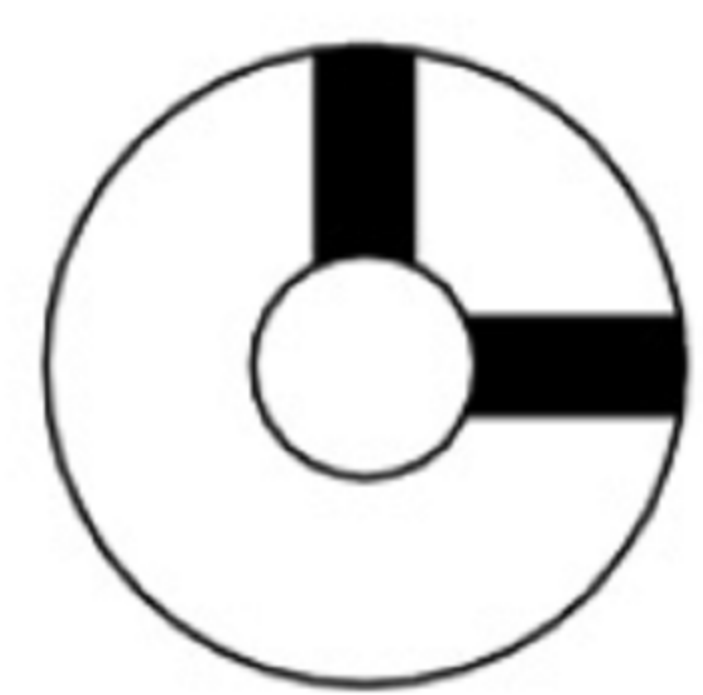
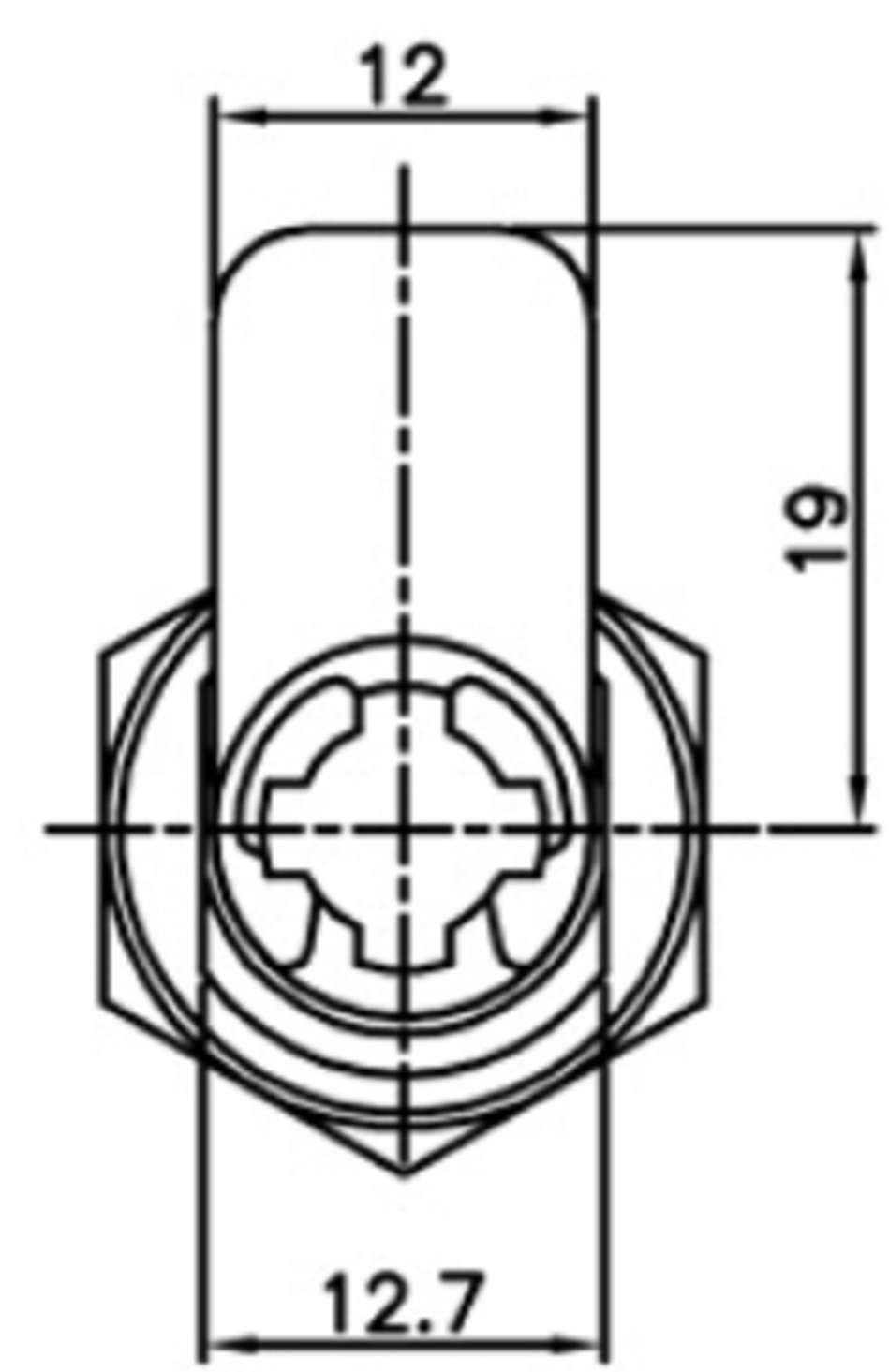

Fig.2



Recommended hole size



Fig No	Lock Number	Positions	Key Pulls	Turn
1	C327-1	2	1	90°
2	C327-2	2	2	90°

广东科斯达电子科技有限公司
GUANG DONG KE SI DA ELECTRONIC TECHNOLOGY CO., LTD.

TOLERANCE UNLESS OTHERWISE STATED:
 Up to 5 ±0.2
 Above 5 ~ 15 ±0.3
 Above 15 ~ 30 ±0.4
 Above 30 ~ 50 ±0.5
 Angle ±0.3

3RD. ANGEL'S

UNITS MM

DRAWN BY:	DATE	MAT'L	TITLE	SWITCH
Jack Lu	12/27/22		MODLE	TACT SWITCH WITH LED
CHECKED BY:	DATE	FINISH	DWG NO.	
Jacky Chen	12/27/22		PART NO.	
APPROVED BY:	DATE	SCALE	SHEET NO.	
Tony Kao	12/27/22	1 : 1	1 of 1	

ITEM NO.	DESCRIPTION	DRAWN	DATE

SIZE
A4
VER
R