

Rating: 10A 125V AC  
6A 250V AC (CQC ENEC CB)

Contact Resistance: 50mΩ Max  
Insulation Resistance: DC 500V 100MΩ Min.  
Dielectric Strength: AC1500V 1 minute  
Operating Force: 550±150gf  
Mechanical Life: Over 30,000 cycles  
Electrical life: Over 10,000 cycles  
Operating Temperature: -20°C~+85°C  
Safety Approval: CQC EN EC 05 KEMA KEUR

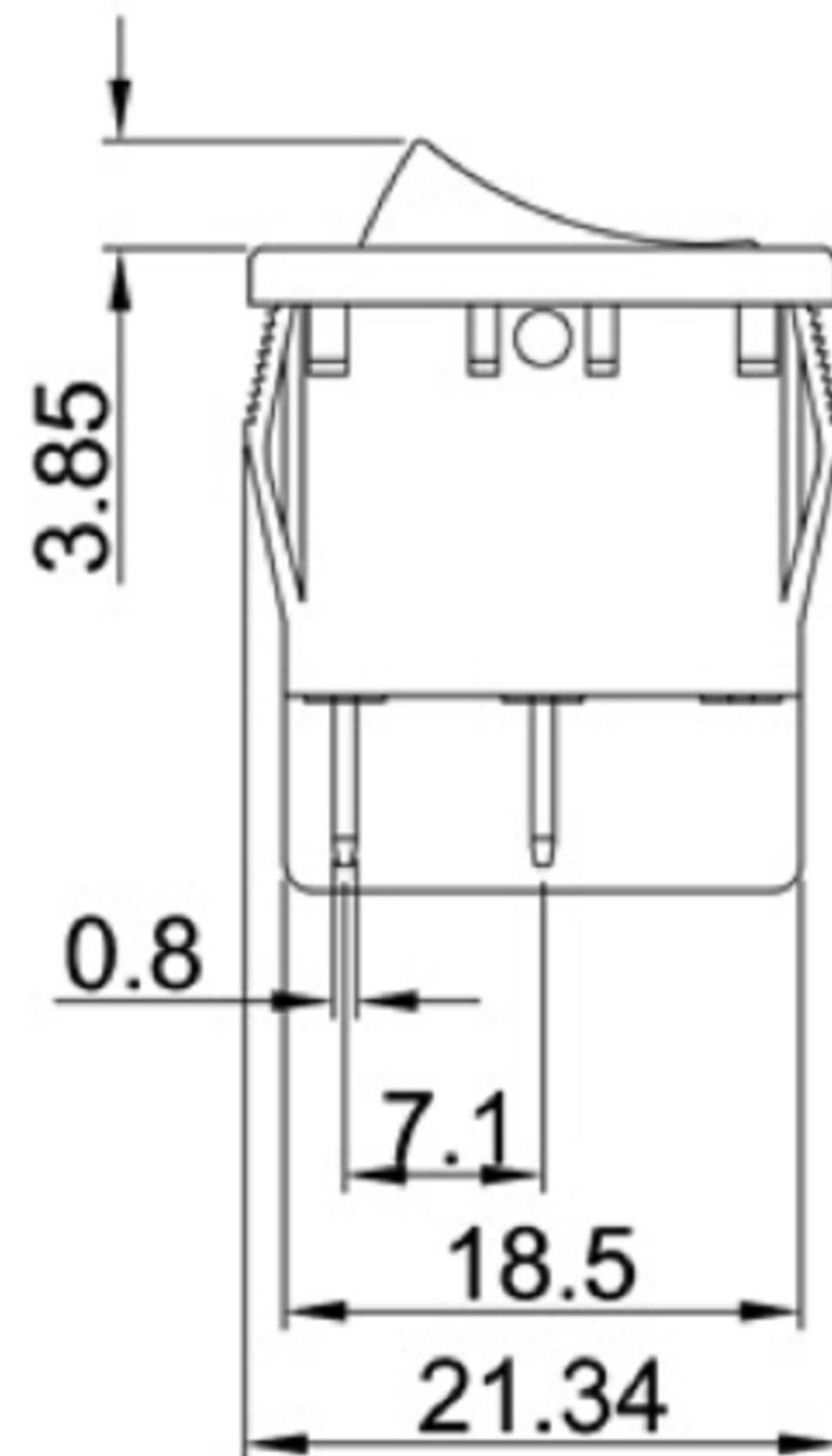

**SWITCHING CIRCUIT**

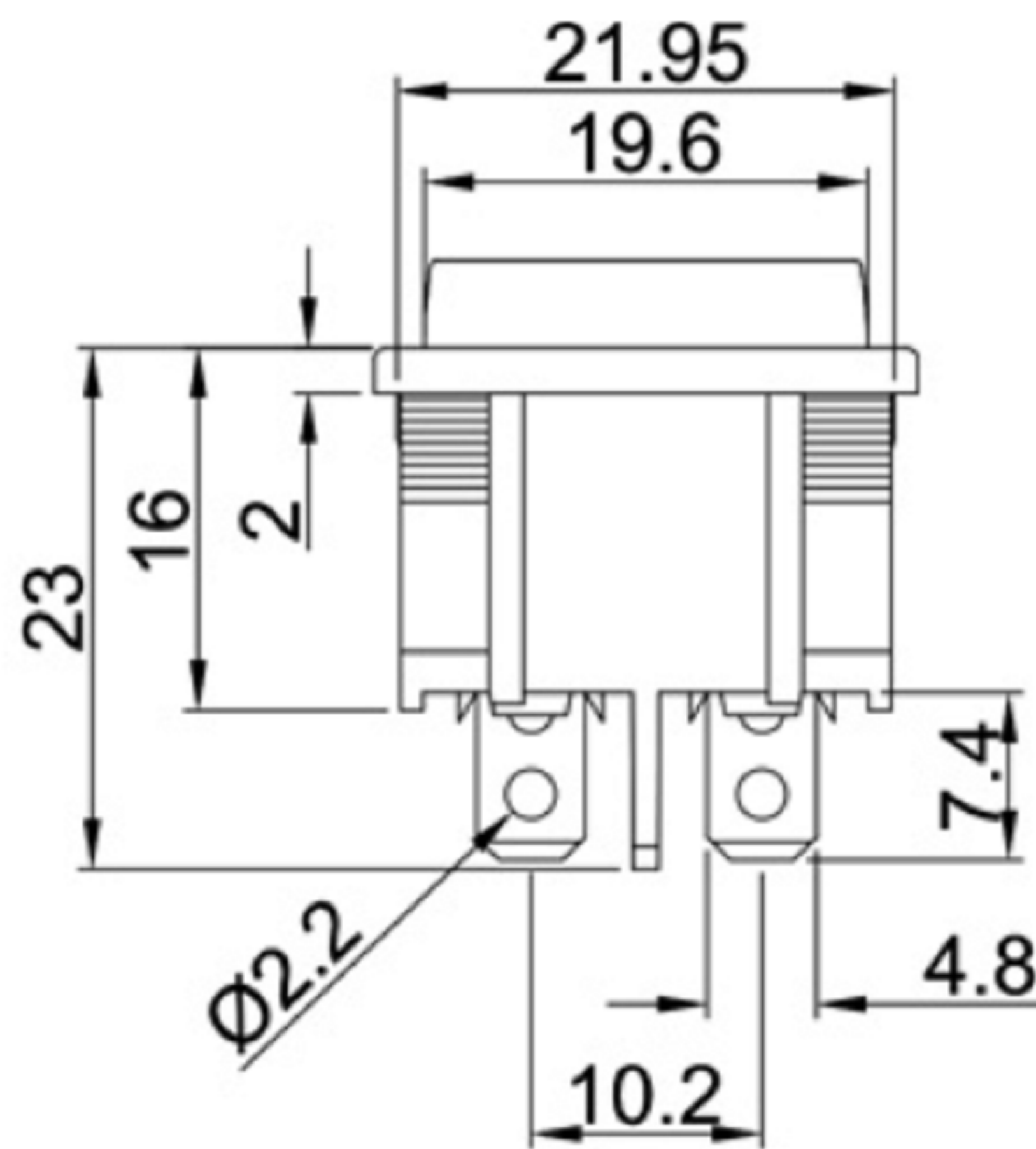
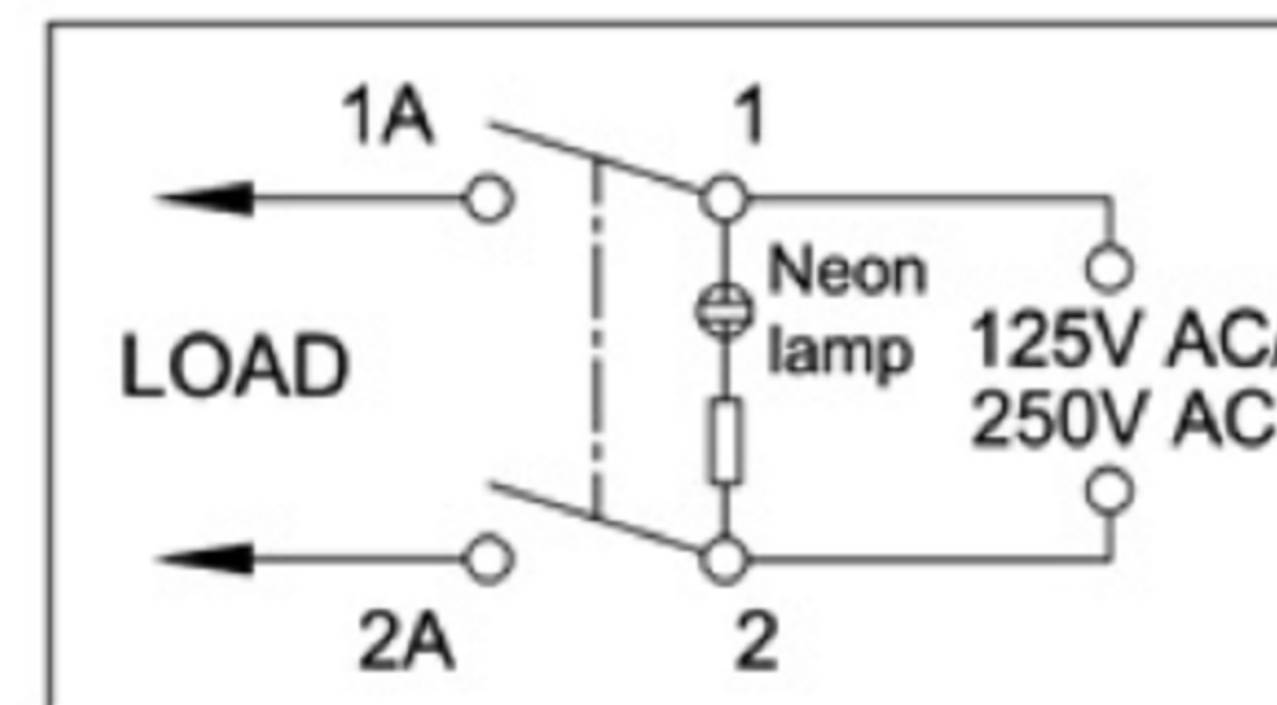

**CUT-OUT**

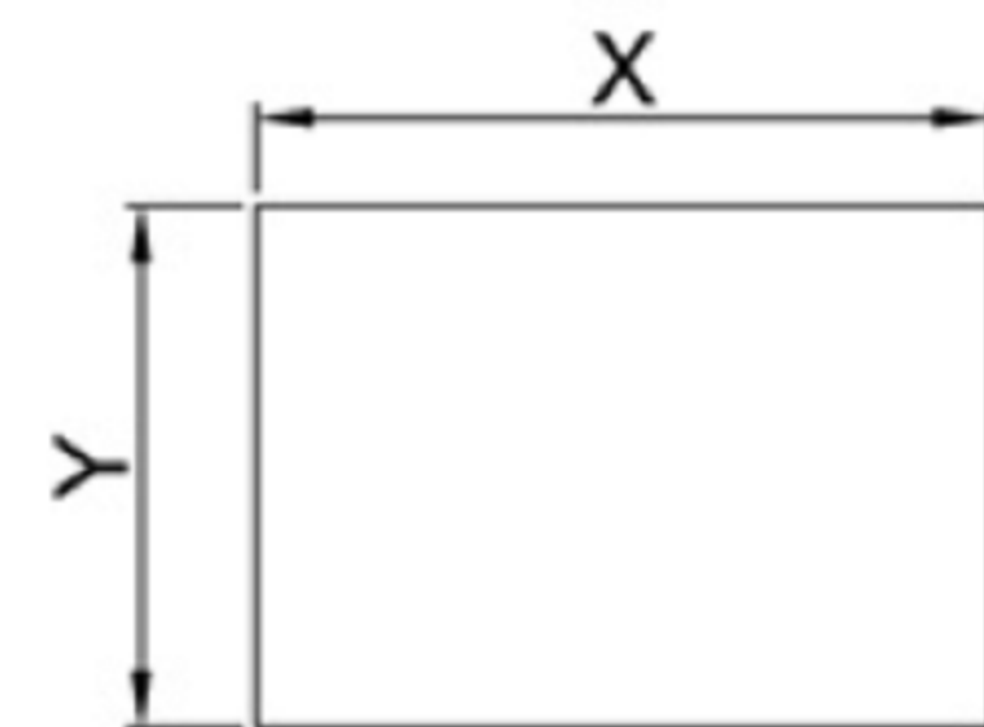

	X	Y
0.75~1.25	21.9~22.0	19.2-0.1
1.25~2.00	21.9~22.0	19.4-0.1
2.00~3.00	21.9~22.0	19.8-0.1

 **广东科斯达电子科技有限公司**  
GUANG DONG KE SI DA ELECTRONIC TECHNOLOGY CO., LTD.

TOLERANCE UNLESS OTHERWISE STATED: Up to 5 ±0.2, Above 5 ~ 15 ±0.3, Above 15 ~ 30 ±0.4, Above 30 ~ 50 ±0.5, Angle ±0.3  
3RD. ANGEL'S  
UNITS MM

DRAWN BY:	DATE	MAT'L	TITLE	SWITCH
Jack Lu	12/27/22			
CHECKED BY:	DATE	FINISH	MODLE	TACT SWITCH WITH LED
Jacky Chen	12/27/22			
APPROVED BY:	DATE	SCALE	DWG NO.	SIZE
Tony Kao	12/27/22	1:1		A4
		SHEET NO.	PART NO.	VER
		1 of 1		R