

Rating: 12A 125VAC
10A 250VAC(CQC / ENEC/CB)
Contact Resistance: 50mΩ max
Insulation Resistance: DC 500V 100MΩ min.
Dielectric Strength: AC 1500V 1 minute
Operating Force: 300±100gf
Mechanical Life: Over 30,000 cycles
Electrical Life: Over 10,000 cycles
Operating Temperature: 0°C ~ 85°C
Safety Approval:

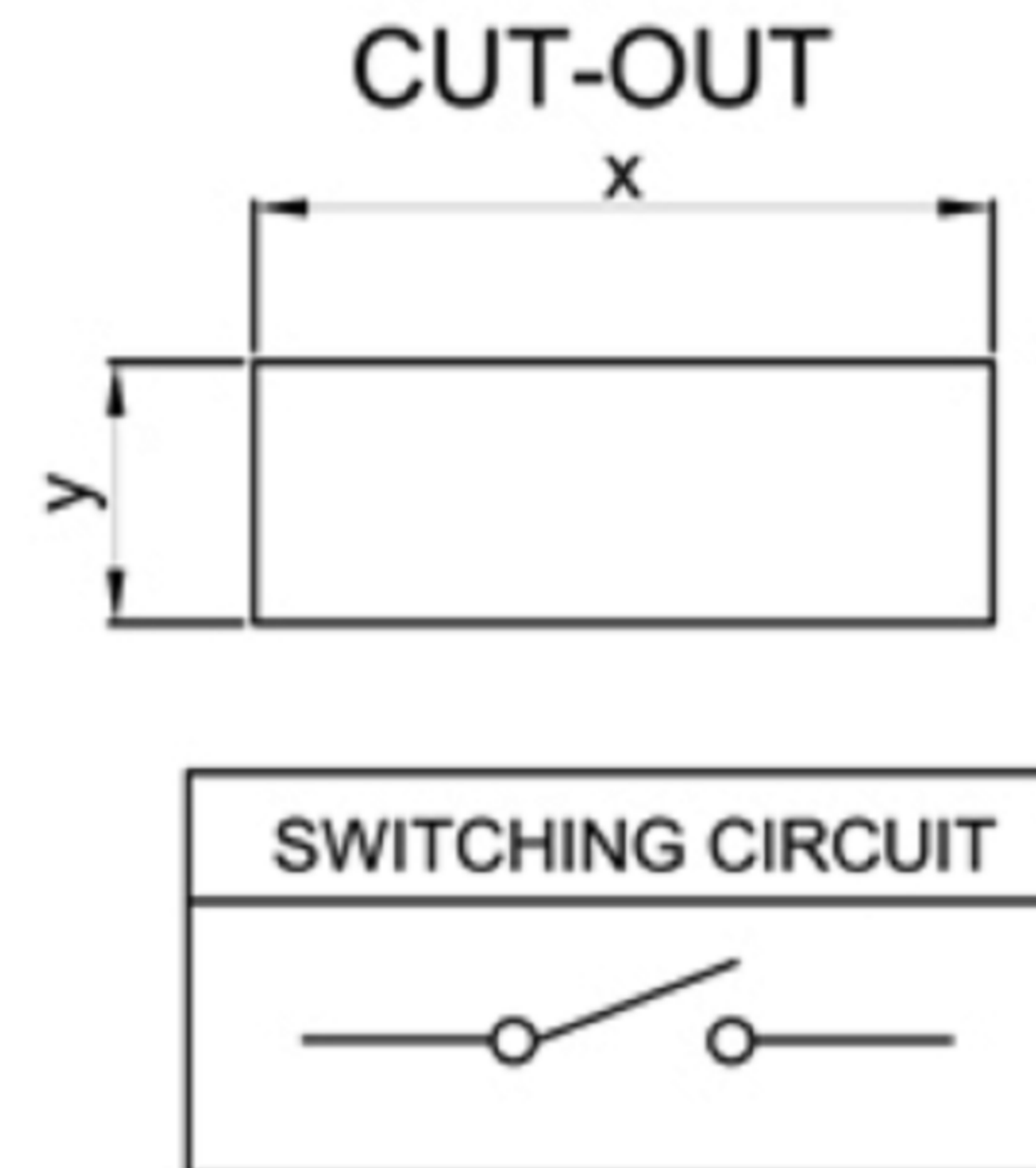
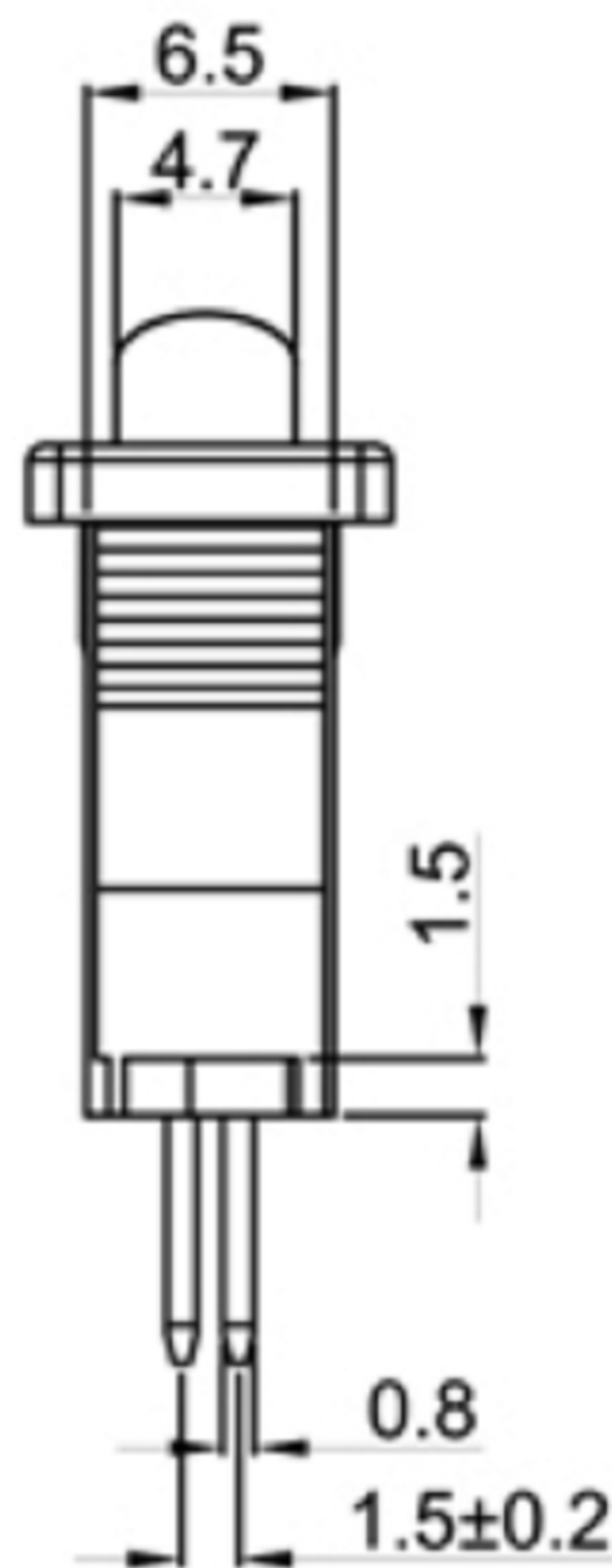
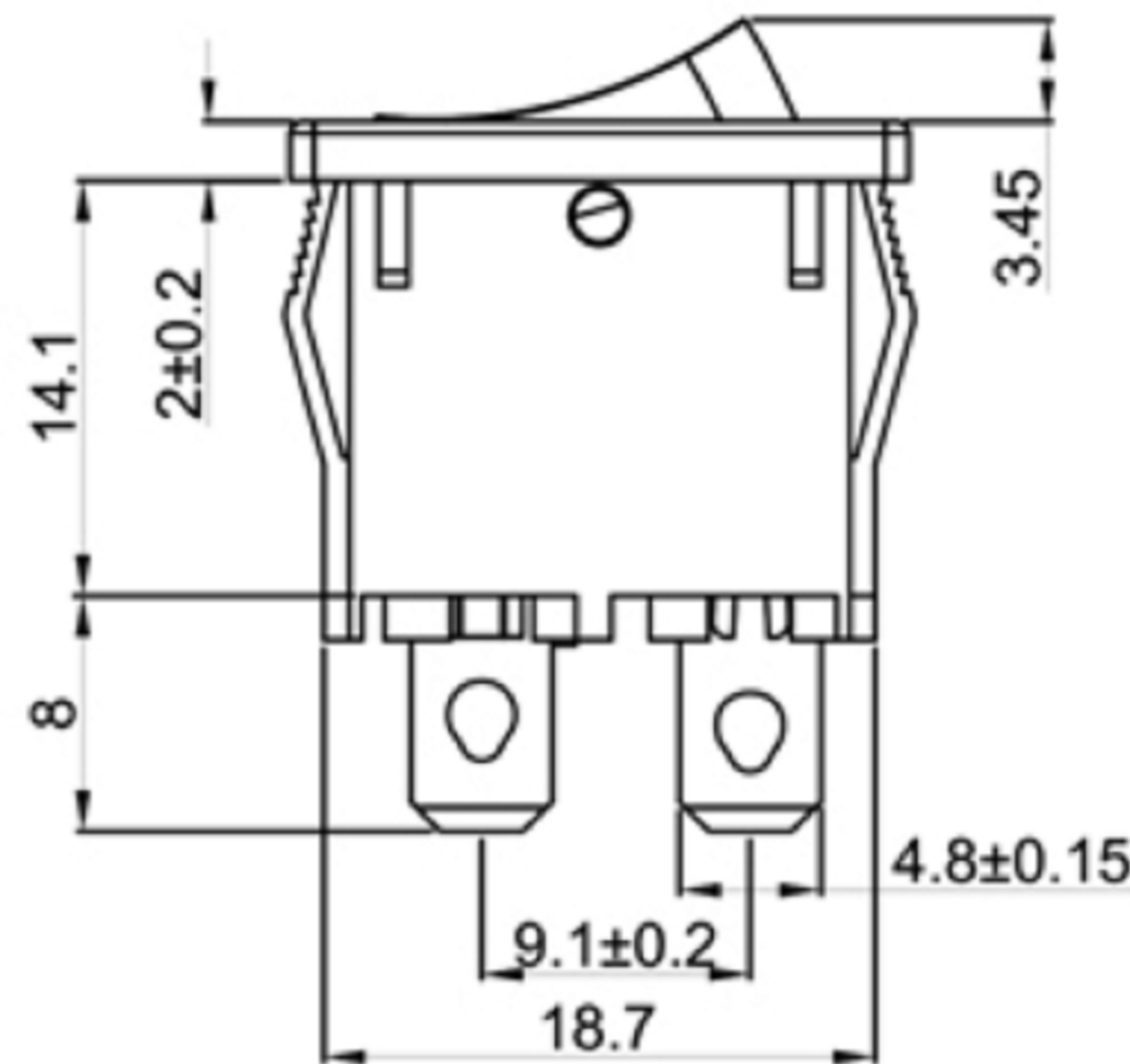

	X	Y
	19.2±0.1	6.8-0.1
	19.4±0.1	6.8-0.1
	19.8±0.1	6.8-0.1

广东科斯达电子科技有限公司
GUANG DONG KE SI DA ELECTRONIC TECHNOLOGY CO., LTD.

TOLERANCE UNLESS OTHERWISE STATED:

Up to 5	±0.2
Above 5 ~ 15	±0.3
Above 15 ~ 30	±0.4
Above 30 ~ 50	±0.5
Angle	±0.3

 3RD. ANGEL'S

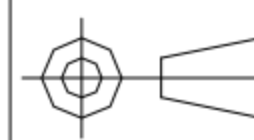

UNITS MM

DRAWN BY:	DATE	MAT'L	TITLE	SWITCH
Jack Lu	12/27/22			
CHECKED BY:	DATE	FINISH	MODLE	TACT SWITCH WITH LED
Jacky Chen	12/27/22			
APPROVED BY:	DATE	SCALE	DWG NO.	
Tony Kao	12/27/22	1 : 1		
		SHEET NO.	PART NO.	
		1 of 1		

ITEM NO.	DESCRIPTION	DRAWN	DATE