

Rating: 6A 125VAC
3A 250VAC

Contact Resistance: 50mΩ max
Insulation Resistance: DC 500V 100MΩ min
Dielectric Strength: AC 1500V 1 minute
Operating Force: 300±100gf
Mechanical Life: 50,000 cycles
Load Life: 10,000 cycles
Operating Temperature: 0°C~85°C

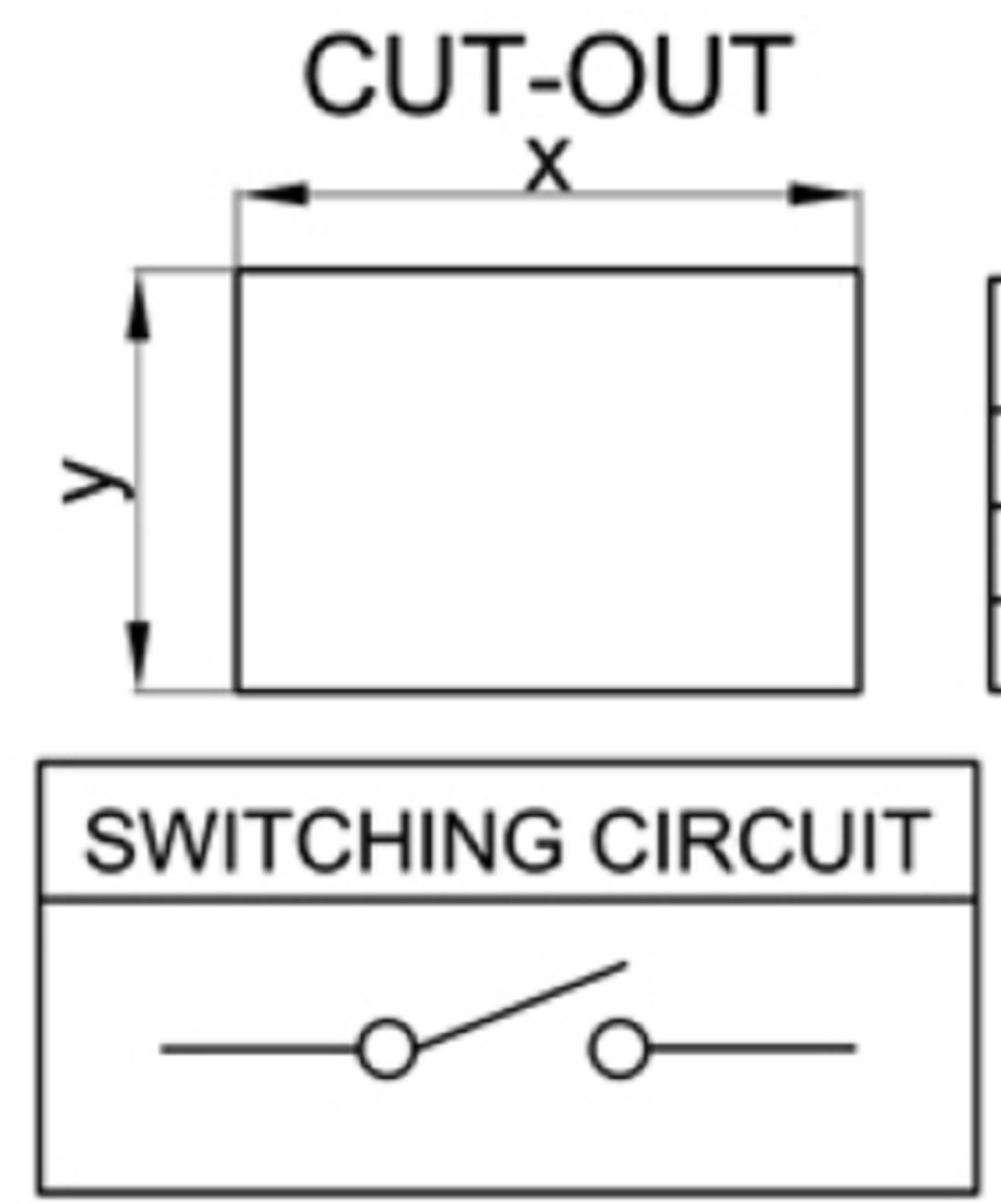

	X	Y
0.75~1.25	13.6-0.1	9.2±0.1
1.25~2.00	13.7-0.1	9.2±0.1
2.00~3.00	13.8-0.1	9.2±0.1

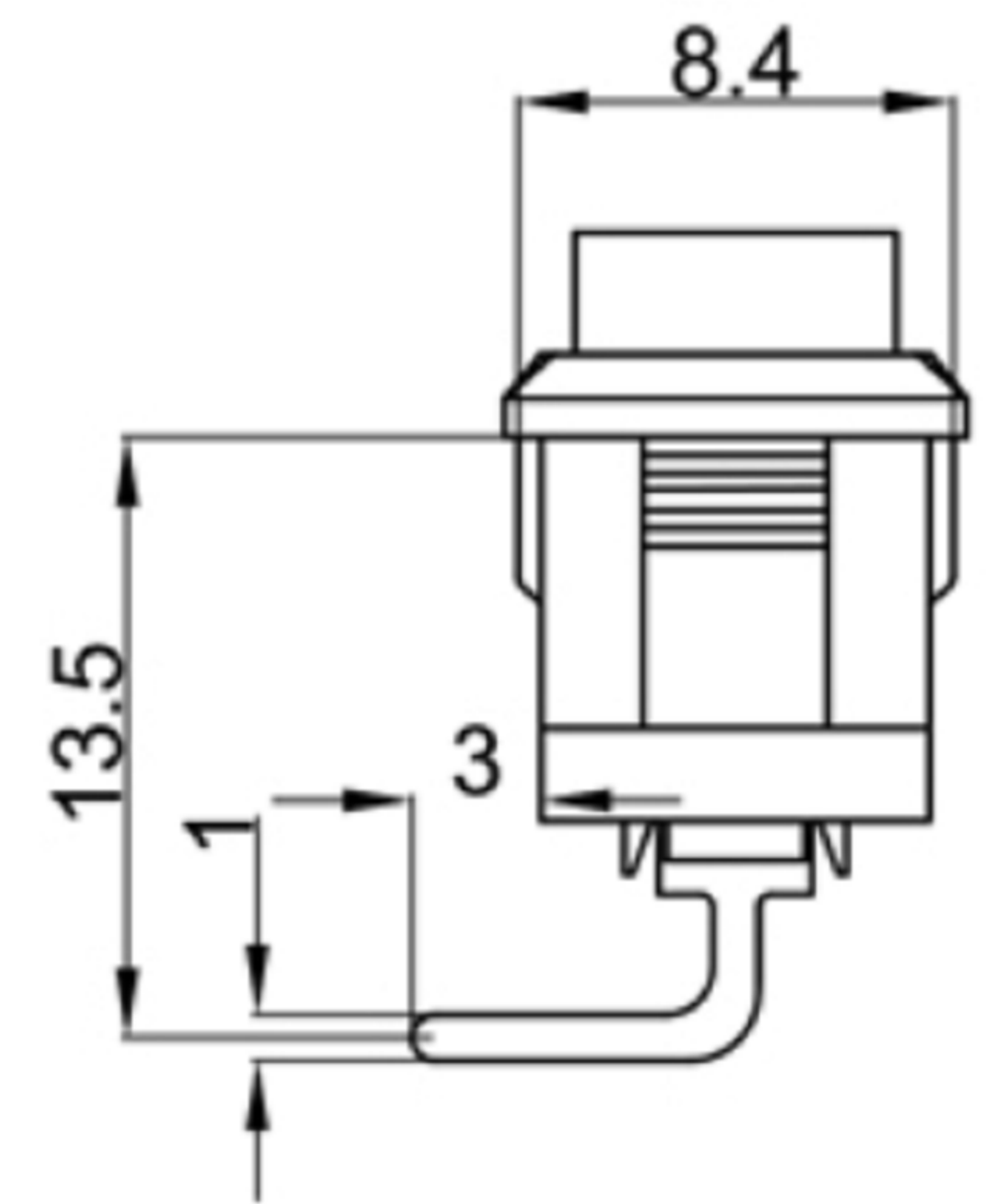
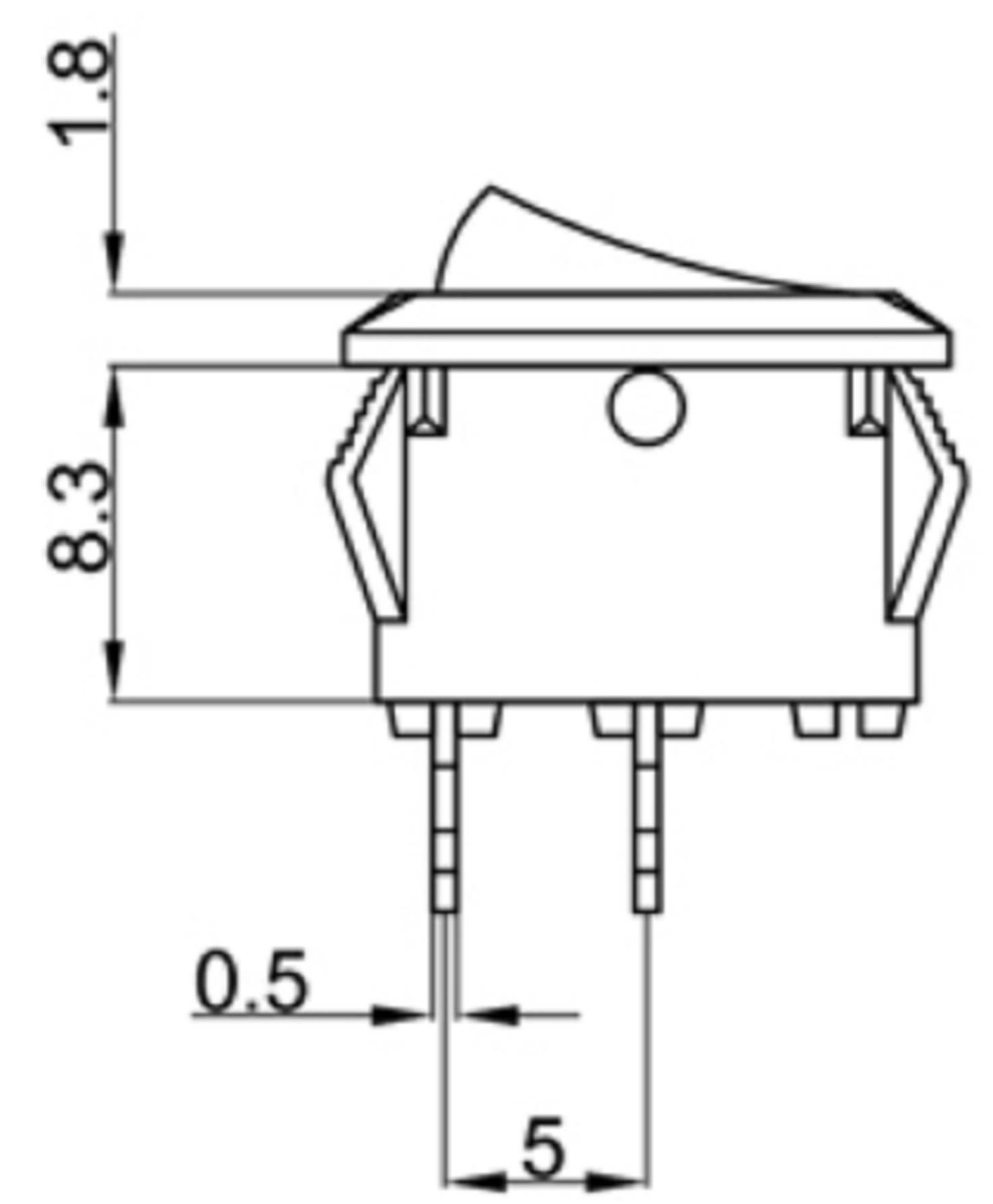
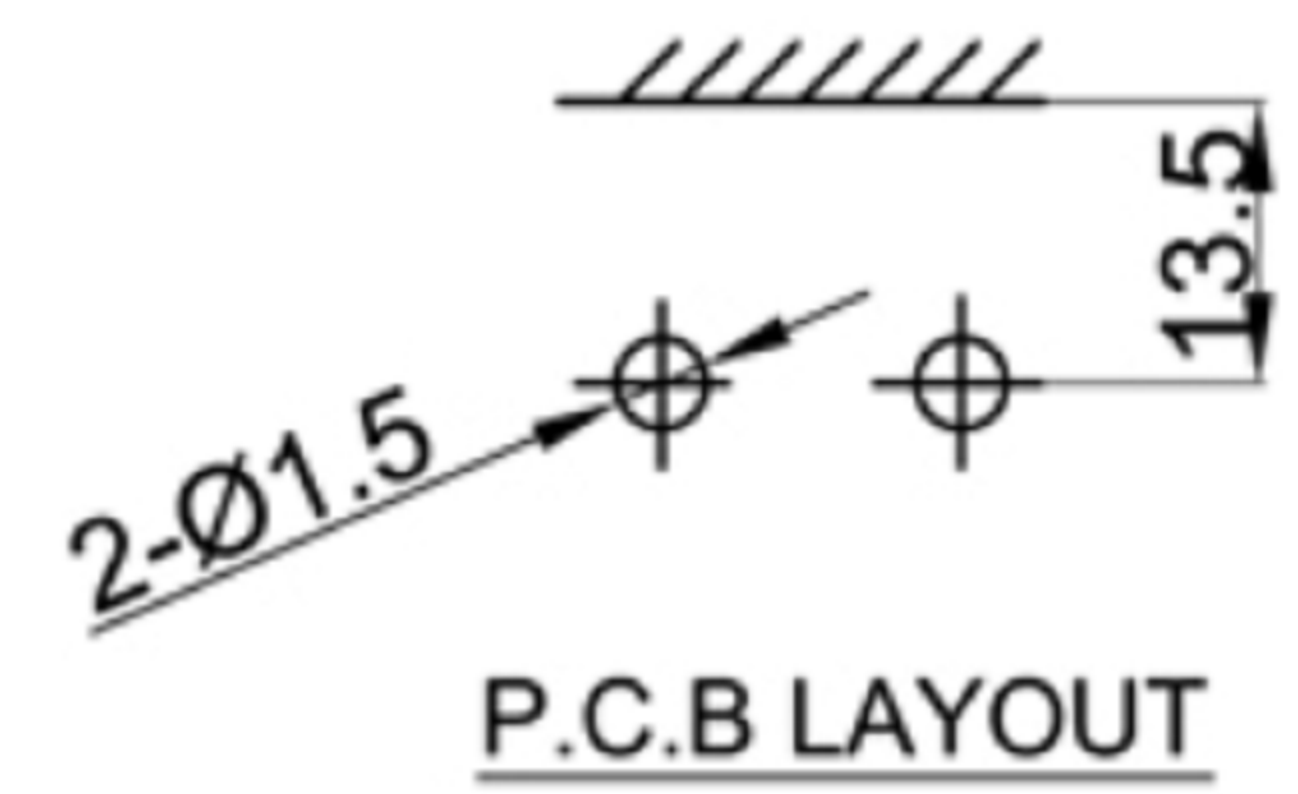

 **广东科斯达电子科技有限公司**
GUANG DONG KE SI DA ELECTRONIC TECHNOLOGY CO., LTD.

TOLERANCE UNLESS OTHERWISE STATED:
Up to 5 ±0.2
Above 5 ~ 15 ±0.3
Above 15 ~ 30 ±0.4
Above 30 ~ 50 ±0.5
Angle ±0.3

3RD. ANGEL'S

UNITS MM

DRAWN BY:	DATE	MAT'L	TITLE	SWITCH
Jack Lu	12/27/22		MODLE	TACT SWITCH WITH LED
CHECKED BY:	DATE	FINISH	DWG NO.	
Jacky Chen	12/27/22		PART NO.	
APPROVED BY:	DATE	SCALE		
Tony Kao	12/27/22	1:1		
		SHEET NO.		
		1 of 1		

ITEM NO.	DESCRIPTION	DRAWN	DATE