

Rating: 16A 125V AC (UL CUL)
 16A 250V AC (UL CUL VDE ENEC CB CQC)
 Contact Resistance: 50m Ω (Max)
 Insulation Resistance: DC 500V 100M Ω (Min)
 Dielectric Strength: AC1500V 1 minute
 Electrical life: 10,000 cycles
 Operating Temperature: 0 °C~85 °C¹⁰
 Safety Approval: cULus **CB**

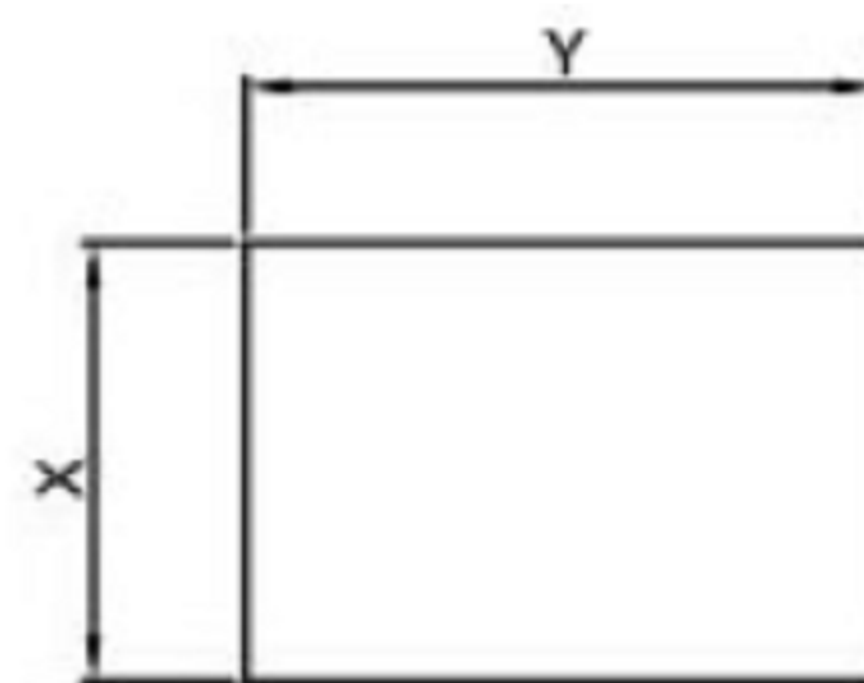

CUT-OUT

	X	Y
0.75~1.25	22.0+0.1	30.0+0.1
1.25~2.00	22.0+0.1	30.2+0.1
2.00~3.00	22.0+0.1	30.4+0.1

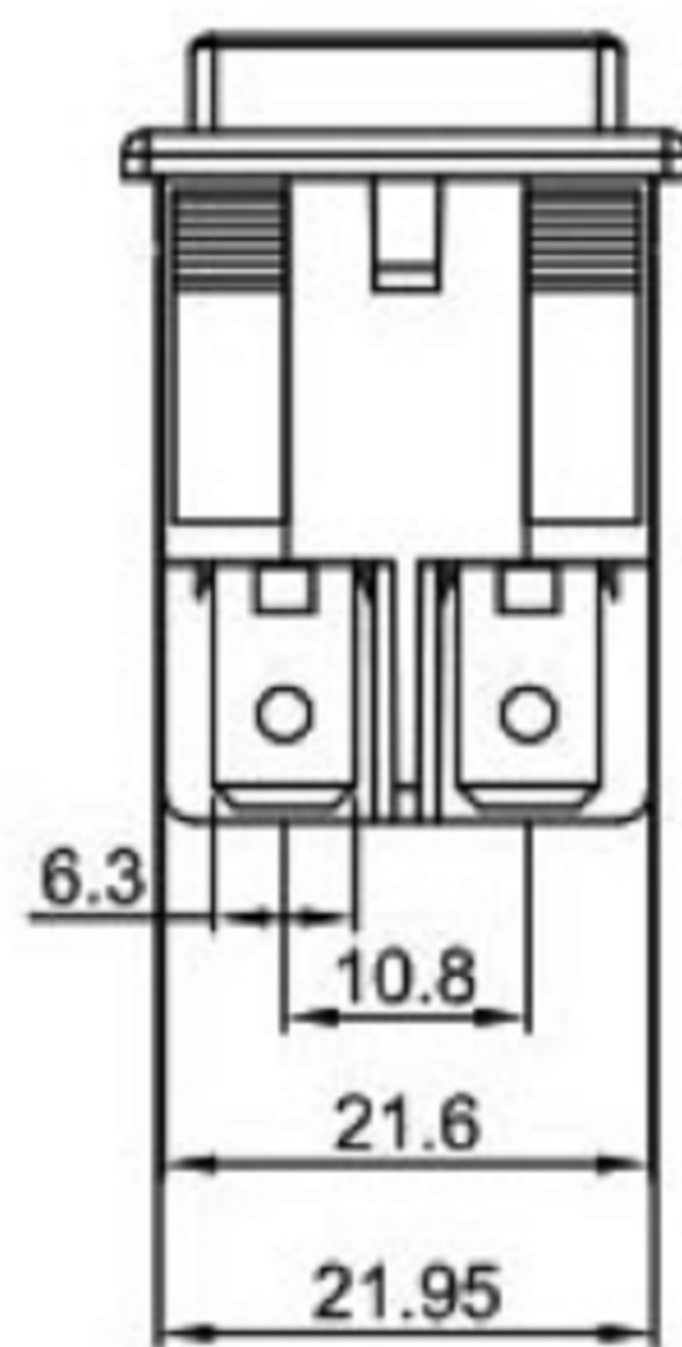
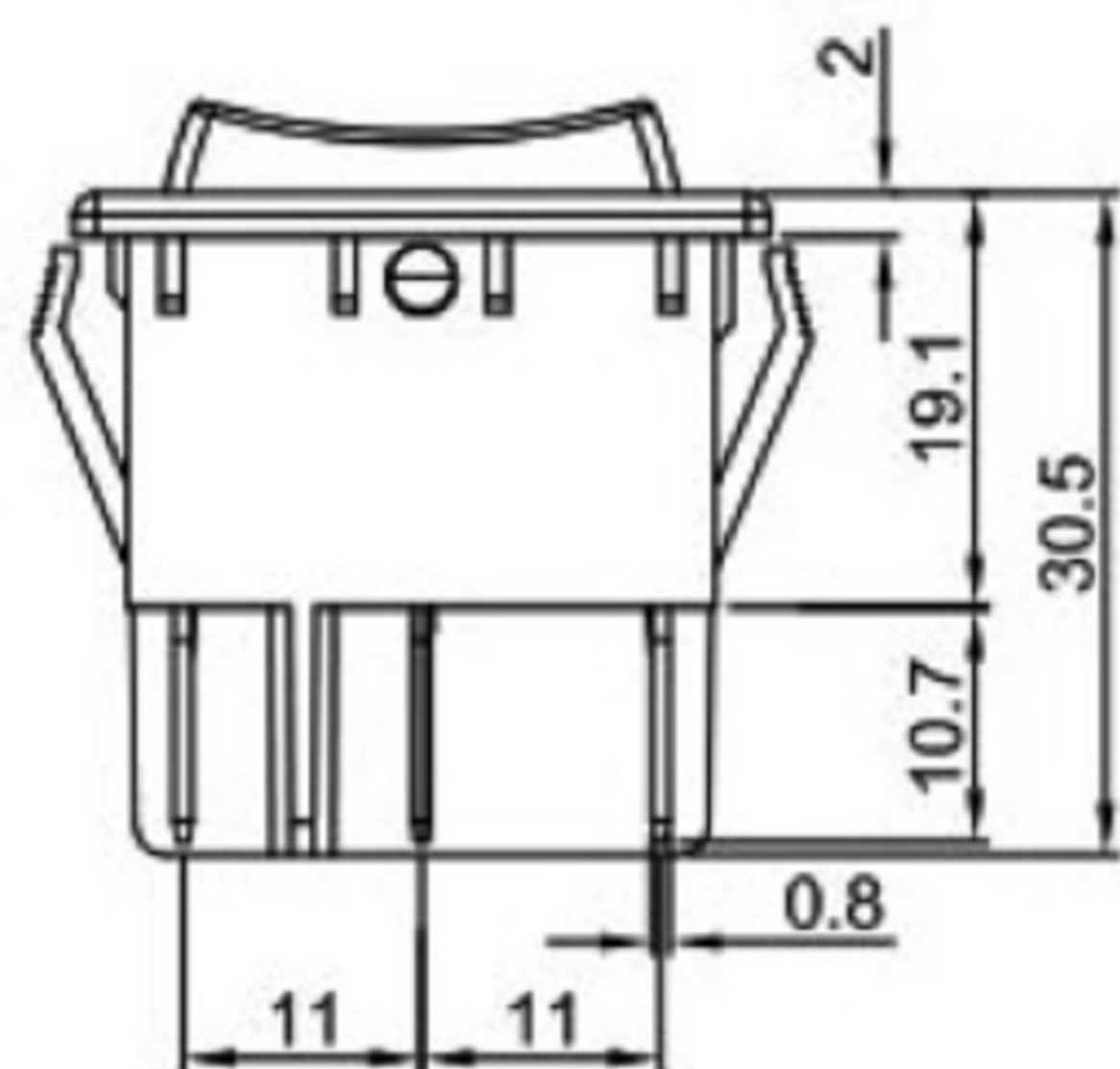
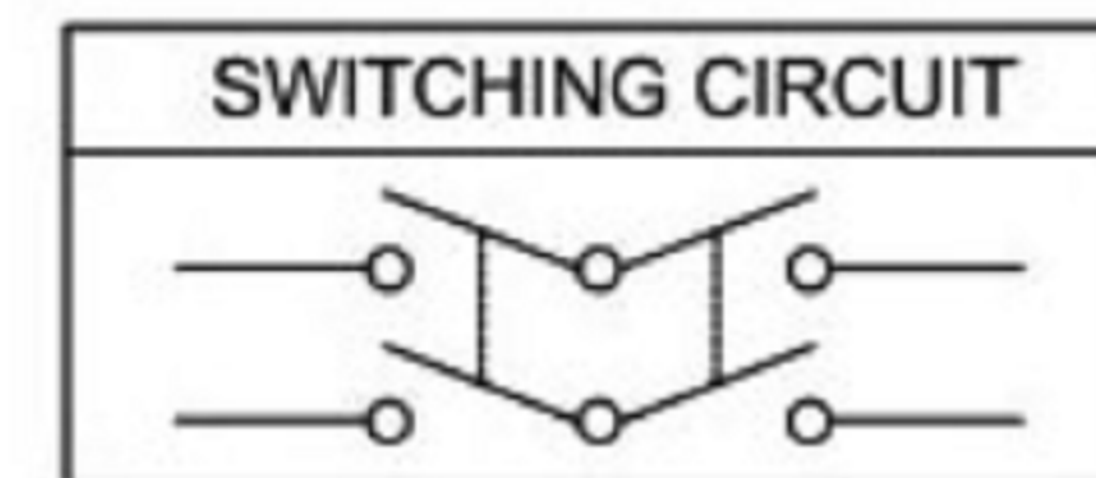

广东科斯达电子科技有限公司
GUANG DONG KE SI DA ELECTRONIC TECHNOLOGY CO., LTD.

TOLERANCE UNLESS OTHERWISE STATED:
 Up to 5 ±0.2
 Above 5 ~ 15 ±0.3
 Above 15 ~ 30 ±0.4
 Above 30 ~ 50 ±0.5
 Angle ±0.3
 3RD. ANGEL'S UNITS MM

DRAWN BY:	DATE	MAT'L	TITLE	SWITCH
Jack Lu	12/27/22			
CHECKED BY:	DATE	FINISH	MODLE	TACT SWITCH WITH LED
Jacky Chen	12/27/22			
APPROVED BY:	DATE	SCALE	DWG NO.	SIZE
Tony Kao	12/27/22	1 : 1		A4
		SHEET NO.	PART NO.	VER
		1 of 1		R