

| REV | DESCRIPTION | DESIGN     | DATE       |
|-----|-------------|------------|------------|
| A0  | NEW RELEASE | FangSongLe | 2020/07/24 |

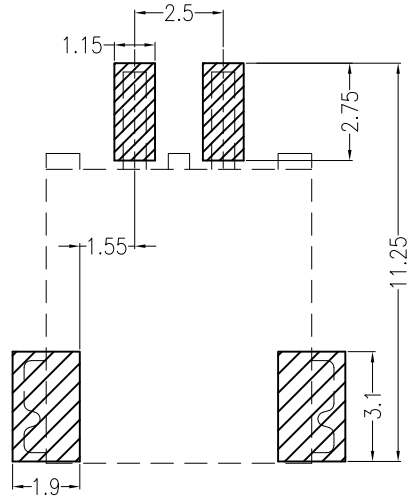

Board Layout

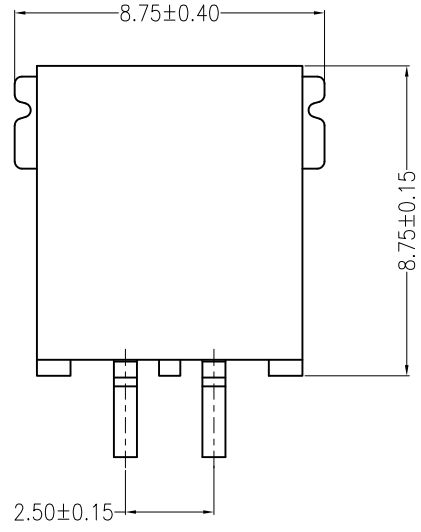
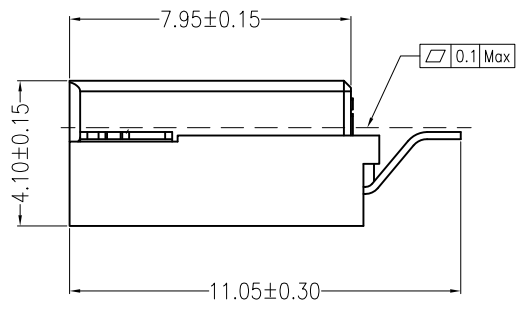
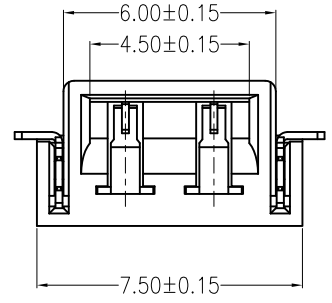
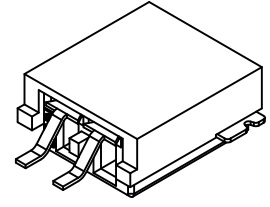

Mating Aluminum plate detail

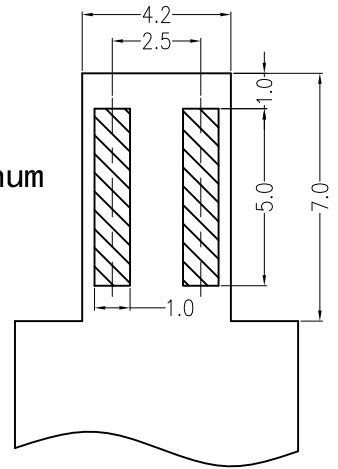

**Specifications:**  
 Contact resistance: ≤20mΩ  
 Insulation resistance: ≥1000MΩ  
 Rated voltage: 250V AC DC  
 Rated current: 2.0A AC DC  
 Withstand Voltage: 1000V AC/minute  
 Temperature Range: -40°C ~ +120°C  
 Housing: LCP UL94V-0, BEIGE  
 Contacts: PhosphorBronze/MATTE Sn-plated

ORDER INFORMATION:

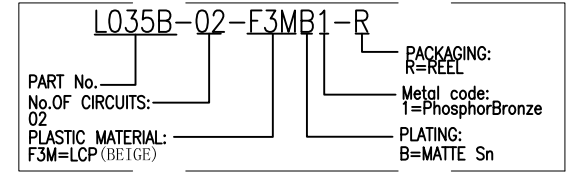

|  |  |  |                                  |
|--|--|--|----------------------------------|
| <b>广东科斯达电子科技有限公司</b><br>GUANG DONG KE SI DA ELECTRONIC TECHNOLOGY CO., LTD.      |  | TITLE:<br>2.5mmPITCH 90°WAFER SMT TYPE                   |                                  |
|  |  | PART NO.:<br>L035B-02-F3MB1-R                            |                                  |
| GENERAL TOLERANCE<br>X. ±0.50 X. ±5°<br>X.X ±0.30 X.X ±2°<br>X.XX ±0.20 X.XX ±1° |  | USE:<br>CUSTOMER<br>APPD:<br>WangFeng<br>CHKD:<br>Steven | DWG NO.:<br>GCKH-2156            |
| <br>UNITS:<br>mm   |  | DR:<br>FangSongLe  | SCALE<br>1 : 1<br>SHEET<br>1 / 1 |