

REV	ECN No.	DESCRIPTION	DESIGN	DATE
A0		Release	李润	2014.04.16

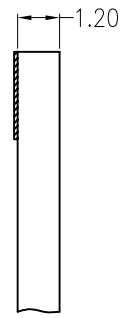

Mating PCB detail

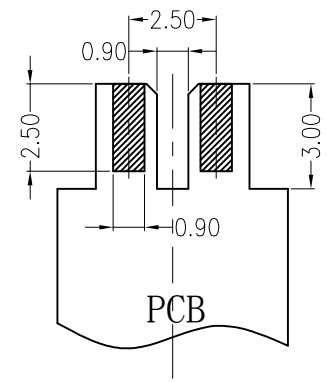
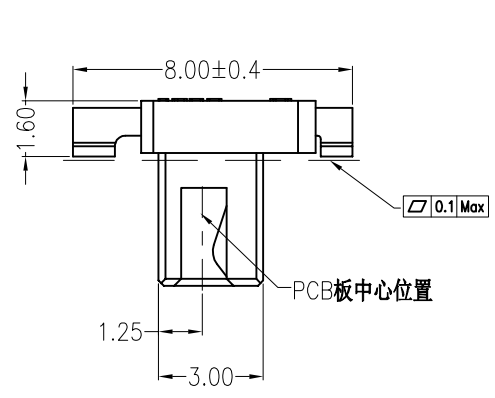
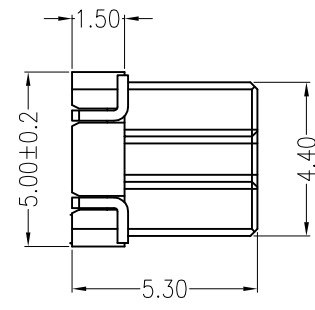
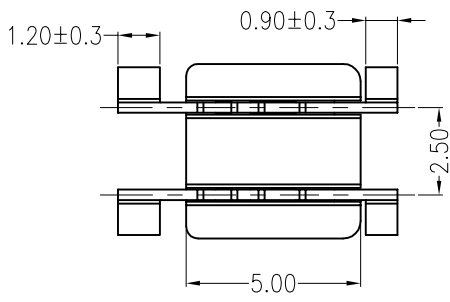
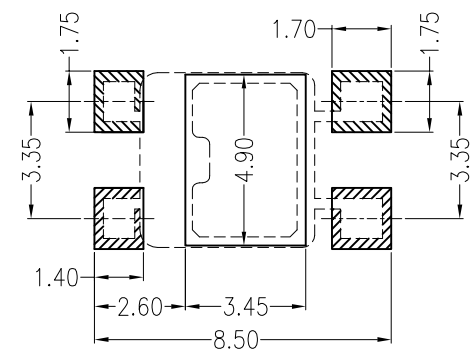
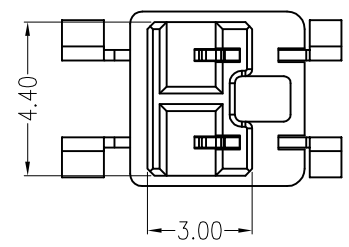

Board Layout

主要技术参数 Main Specifications

- 板厚 (thickness): 1.2mm
- 接触电阻 (Contact resistance):  $\leq 20m\Omega$
- 绝缘电阻 (Insulation resistance):  $\geq 800M\Omega$
- 额定电压 (Rated voltage): 125V AC DC
- 额定电流 (Rated current): 1.0A AC DC
- 耐电压 (Withstand Voltage): 800V AC/minute
- 温度范围 (Temperature Range):  $-40^{\circ}C \sim +105^{\circ}C$

ORDER INFORMATION:

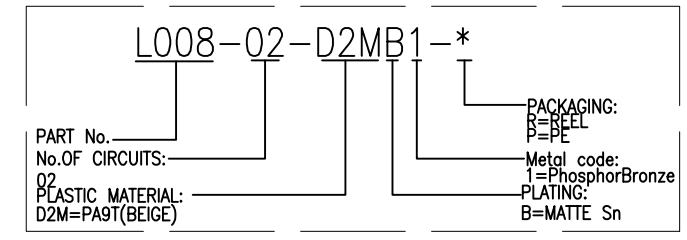

ITEM	COMPONENT	Q'TY	MATERIAL	FINISH
C				
B	CONTACT	2 PCS	PhosphorBronze	Tin-plated
A	HOUSING	1 PCS	PA9T	UL 94V-0, COLOR:BEIGE

**广东科斯达电子科技有限公司**  
**GUANG DONG KE SI DA ELECTRONIC TECHNOLOGY CO., LTD.**

TITLE: L008-02-1\*  
 2.5Pitch 180°wafer smt type

X.±0.5	X.±5'	USE: CUSTOMER	PART NO.:	
.X±0.3	.X±2'		L008-02-D2MB1-*	
.XX±0.25	.XX±1'	APPD: 邵敬和	DWG NO.:	
--	--	CHKD: 田峰	GCCP-0017	
UNITS: mm		DR: 吴丹平	SCALE 1 : 1	SHEET 1 / 1

A

B

C

D

E

F

REV	DESCRIPTION	DESIGN	DATE
A0	Release	吴丹平	2016.05.13

1

1

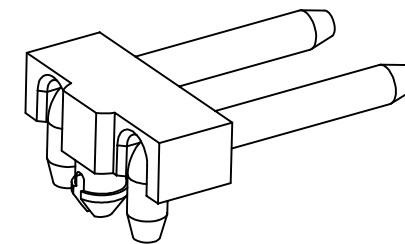
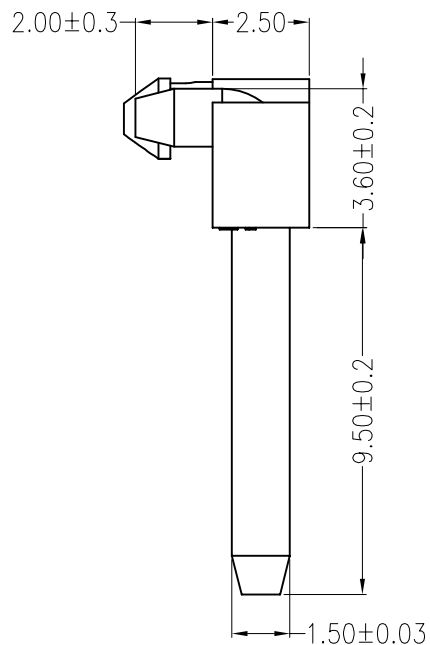
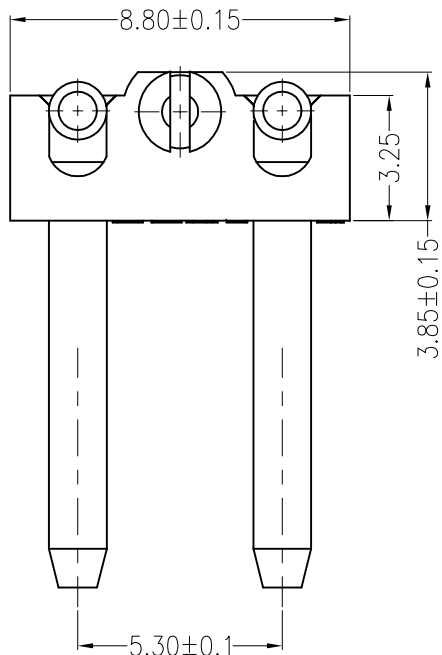

SUGGESTED PCB LAYOUT  
(COMPONENT SIDE)

### 主要技术参数 Main Specifications

接触电阻 (Contact resistance):  $\leq 20m\Omega$   
 绝缘电阻 (Insulation resistance):  $\geq 1000M\Omega$   
 额定电压 (Rated voltage): 250V AC DC  
 额定电流 (Rated current): 3.0A AC DC  
 耐电压 (Withstand Voltage): 1000V AC/minute  
 温度范围 (Temperature Range):  $-40^{\circ}C \sim +110^{\circ}C$

ORDER INFORMATION:

L018B-02-B1MG-P-A			
PART No.			SPECIAL CODE: A=9.5X2.0
No. FOR CIRCUITS:			PACKAGING: P=PE
PLASTIC MATERIAL:			PLATING: G=Ni
B1M=PA46 (BEIGE)			

3

3

4

4

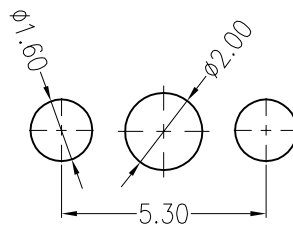
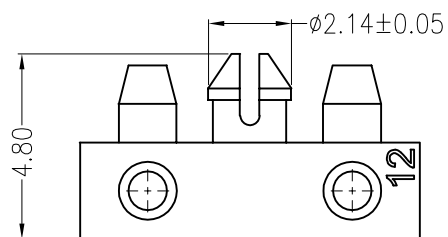

Board Layout  
General Tolerance:  $\pm 0.05$

5

5

A

B

C

D

E

F

C				
B	CONTACT	2 PCS	Brass	Ni-plated
A	PEDESTAL	1 PCS	LCP	UL 94V-0, COLOR:BEIGE
ITEM	COMPONENT	Q'TY	MATERIAL	FINISH
<b>广东科斯达电子科技有限公司</b> GUANG DONG KE SI DA ELECTRONIC TECHNOLOGY CO., LTD.		TITLE: -		5.3mmPITCH 90°WAFER DIP TYPE
X.±0.5	X.±5'	USE:	PART NO.:	
.X±0.3	.X±2'	CUSTOMER	L018B-02-B1MG-P-A	
.XX±0.25	.XX±1'	APPD:	DWG NO.:	
--	--	邵敬和	CCP-0286	
	UNITS:	CHKD:	SCALE	SHEET
mm	mm	田峰	1 : 1	1 / 1
		DR:		
		蒋建银		