

| REV | DESCRIPTION | DESIGN | DATE |
|-----|-------------|--------|------------|
| A0 | Release | 吴丹平 | 2013.08.05 |

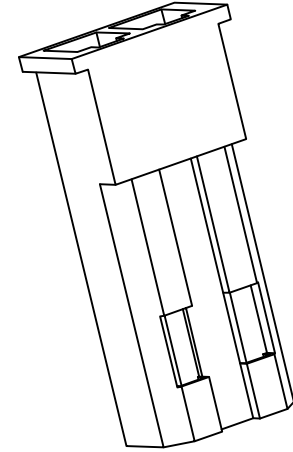
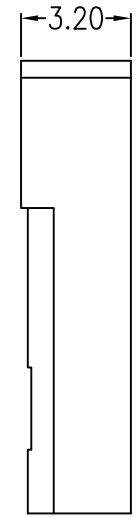
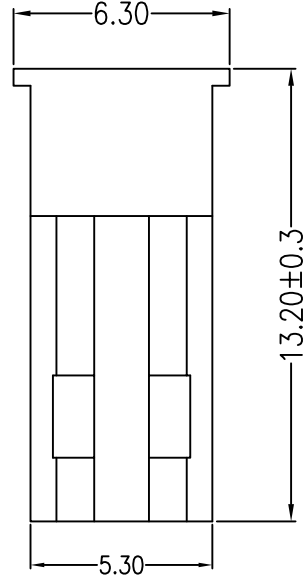
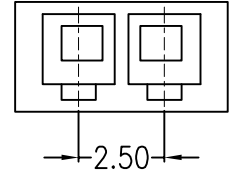

主要技术参数 Main Specifications

- 线 数 (Poles): 02
- 接触电阻 (Contact resistance): $\leq 20m\Omega$
- 绝缘电阻 (Insulation resistance): $\geq 1000M\Omega$
- 额定电压 (Rated voltage): 250V AC DC
- 额定电流 (Rated current): 3.0A AC DC
- 耐 电 压 (Withstand Voltage): 1000V AC/minute
- 温度范围 (Temperature Range): $-25^{\circ}C \sim +85^{\circ}C$

ORDER INFORMATION:

C2502P-02-A5W-P

| | |
|-------------------------|-------------------|
| PART No. _____ | PACKAGING: |
| No. FOR CIRCUITS: _____ | P=PE |
| 02 | PLASTIC MATERIAL: |
| | A5W=PA66 (BEIGE) |
| | A5R=PA66 (RED) |

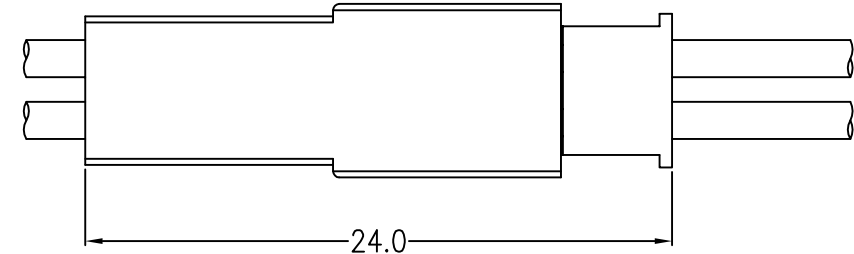

Assembly Layout

| | | | | | |
|---|-----------|-------|----------|--------|--|
| C | | | | | |
| B | | | | | |
| A | PEDESTAL | 1 PCS | PA66 | | |
| ITEM | COMPONENT | Q'TY | MATERIAL | FINISH | |
| 广东科斯达电子科技有限公司 GUANG DONG KE SI DA ELECTRONIC TECHNOLOGY CO., LTD. | | | TITLE: | | |
| X.±0.5 | X.±5' | USE: | CUSTOMEP | | |
| .X±0.3 | .X±2' | APPD: | 邵敬和 | | |
| .XX±0.25 | .XX±1' | CHKD: | 田 峰 | | |
| -- | -- | DR: | 吴丹平 | | |
| UNITS: mm | | SCALE | | SHEET | |
| | | 1 : 1 | | 1 / 1 | |

A

B

C

D

E

F

| REV | ECN No. | DESCRIPTION | DESIGN | DATE |
|-----|---------|-------------|--------|------------|
| A0 | | Release | ??? | 2018.01.22 |
| | | | | |

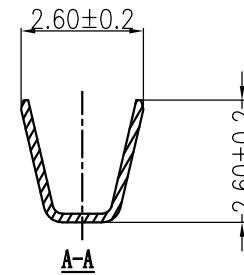
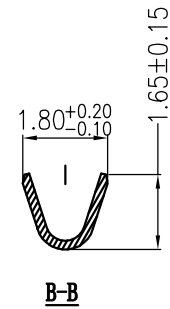
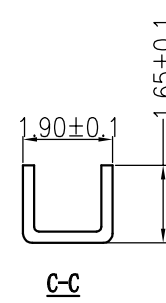
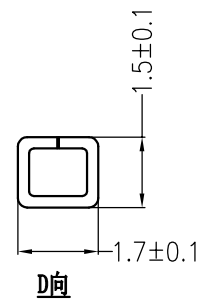
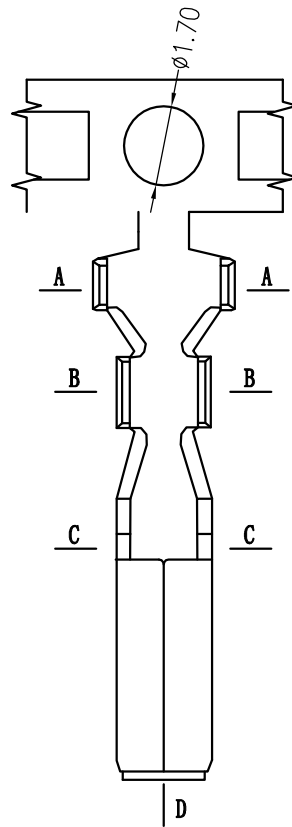
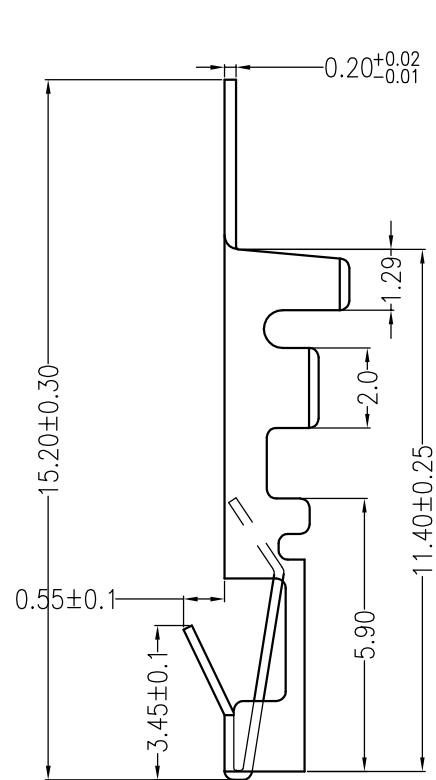

Ordering Information & Specification:

| Part No | Wire Range | Insulation O.D. | Material | Finish | Qty/Reel |
|------------|-------------|-----------------|-----------------|-----------|----------|
| C2502PT-PA | AWG #22~#28 | 1.0~1.80mm | Phosphor bronze | Sn-plated | 9000 pcs |



TITLE: C2502PT

| | | | |
|----------|--------|--------|----------|
| X.±0.5 | X.±5' | USE: | CUSTOMER |
| .X±0.3 | .X±2' | APPD: | 邵敬和 |
| .XX±0.25 | .XX±1' | CHKD: | 田峰 |
| ⊕ | ⚡ | UNITS: | mm |
| | | DR: | 蒋建银 |

| | |
|----------------|-------|
| PART NO.: | |
| C2502PT-PA | |
| DWG NO.: | |
| JKUN-GCDZ-0031 | |
| SCALE | SHEET |
| 1 : 1 | 1 / 1 |

A

B

C

D

E

F

1

2

3

4

5

1

2

3

4

5

A

B

C

D

E

F

| REV | DESCRIPTION | DESIGN | DATE |
|-----|-------------|--------|------------|
| A0 | Release | 吴丹平 | 2013.08.05 |

1

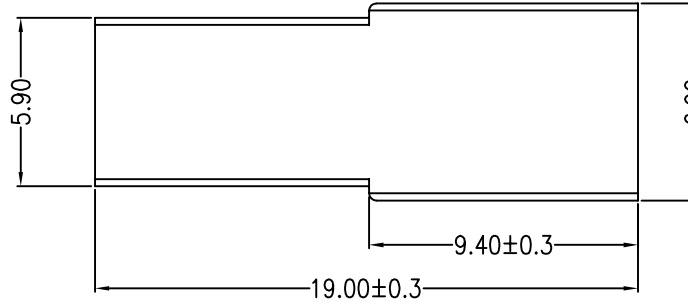
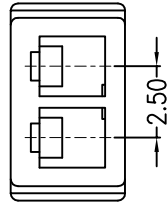

2

主要技术参数 Main Specifications

线 数 (Poles): 02

接触电阻 (Contact resistance): $\leq 20\text{m}\Omega$

绝缘电阻 (Insulation resistance): $\geq 1000\text{M}\Omega$

额定电压 (Rated voltage): 250V AC DC

额定电流 (Rated current): 3.0A AC DC

耐 电 压 (Withstand Voltage): 1000V AC/minute

温度范围 (Temperature Range): $-25^{\circ}\text{C} \sim +85^{\circ}\text{C}$

3

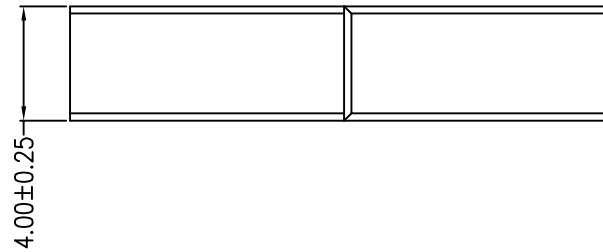
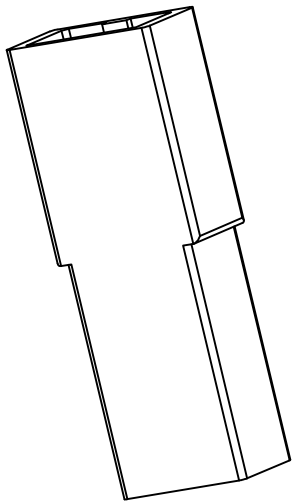

4

ORDER INFORMATION:

C2502R-02-A5W-P

PART No. _____
 No. FOR CIRCUITS: _____
 02

PACKAGING:
 P=PE
 PLASTIC MATERIAL:
 A5W=PA66 (BEIGE)
 A5R=PA66 (RED)

1

2

3

4

5

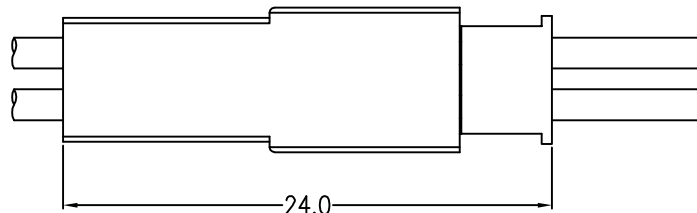

Assembly Layout

A

B

C

D

E

F

| | | | | |
|---|-----------|-------|----------|-----------------|
| C | | | | |
| B | | | | |
| A | PEDESTAL | 1 PCS | PA66 | |
| ITEM | COMPONENT | Q'TY | MATERIAL | FINISH |
| 广东科斯达电子科技有限公司 GUANG DONG KE SI DA ELECTRONIC TECHNOLOGY CO., LTD. | | | | TITLE: |
| X.±0.5 | X.±5' | USE: | CUSTOMEP | PART NO.: |
| .X±0.3 | .X±2' | APPD: | 邵敬和 | C2502R-02-A5W-P |
| .XX±0.25 | .XX±1' | CHKD: | 田峰 | DWG NO.: |
| -- | -- | DR: | 吴丹平 | JKUN/GCCP-0599 |
| UNITS: mm | | SCALE | | SHEET |
| | | 1 : 1 | | 1 / 1 |

| REV | ECN No. | DESCRIPTION | DESIGN | DATE |
|-----|---------|-------------|--------|------------|
| A0 | | Release | 蒋建银 | 2018.01.20 |

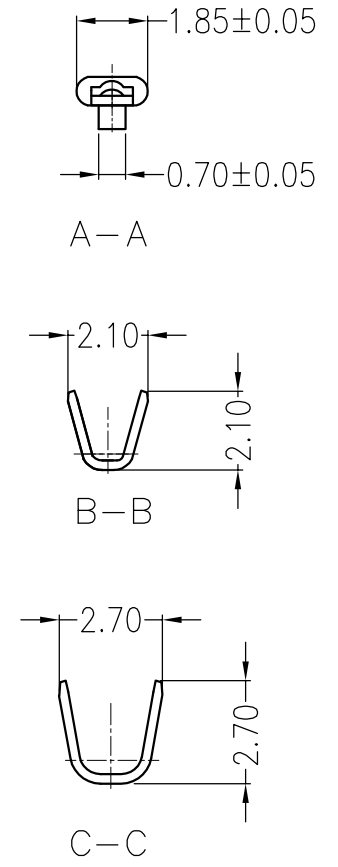
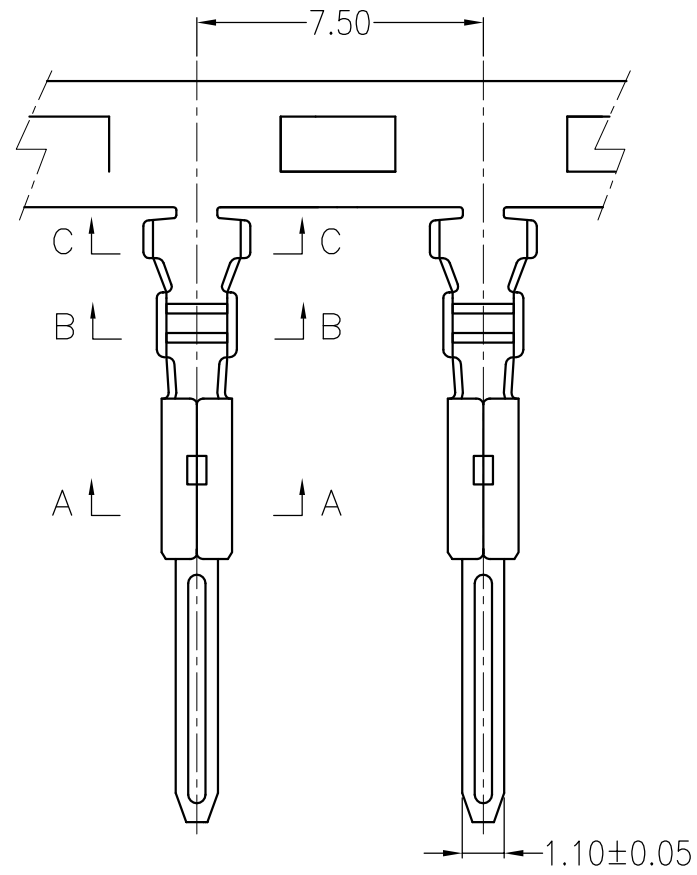
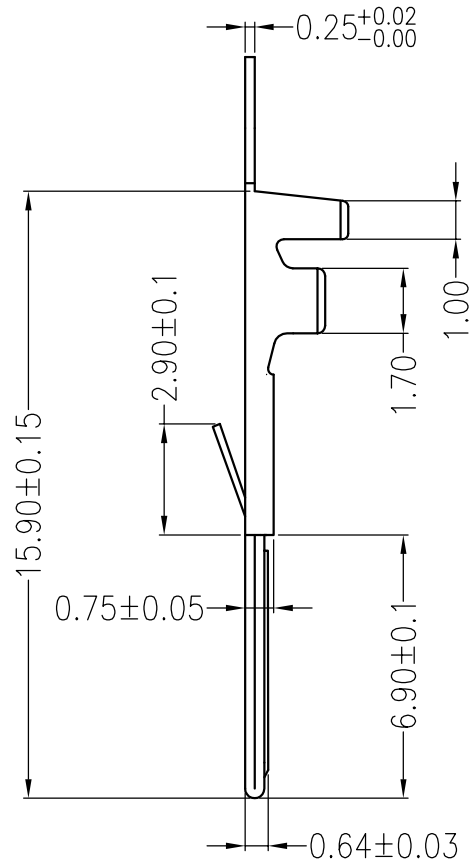

Ordering Information & Specification:

| Part No | Wire Range | Insulation O. D. | Material | Finish | Qty/Reel |
|------------|-------------|------------------|-----------------|-----------|------------|
| C2501RT-PA | AWG #22~#28 | 1.0~1.80mm | Phosphor bronze | Sn-plated | 10,000 pcs |

| | | | |
|---|--------|----------------|-------------------------|
| 广东科斯达电子科技有限公司 GUANG DONG KE SI DA ELECTRONIC TECHNOLOGY CO., LTD. | | TITLE: C2501RT | |
| X±0.5 | X±5' | USE: CUSTOMER | PART NO.: C2501RT-PA |
| .X±0.3 | .X±2' | APPD: 邵敬和 | DWG NO.: JKUN-GCDZ-0029 |
| .XX±0.25 | .XX±1' | CHKD: 田峰 | SCALE: 1 : 1 |
| -- | -- | DR: 蒋建银 | SHEET: 1 / 1 |
| UNITS: mm | | | |