

A

B

C

D

E

F

REV	DESCRIPTION	DESIGN	DATE
A0	Release	吴丹平	2016.04.30

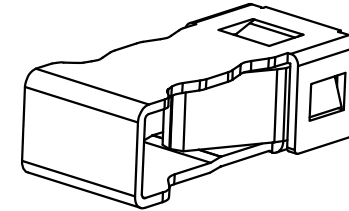
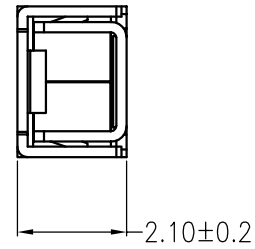
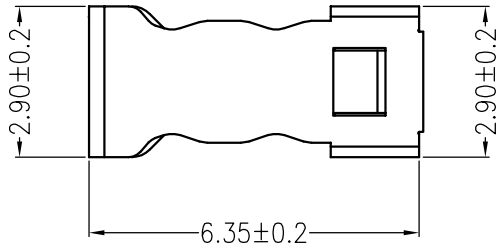

主要技术参数 Main Specifications

线数 (Poles): 01

接触电阻 (Contact resistance): $\leq 20m\Omega$

绝缘电阻 (Insulation resistance): $\geq 800M\Omega$

额定电压 (Rated voltage): 250 V AC DC

额定电流 (Rated current): 2.0A AC DC

耐电压 (Withstand Voltage): 1500V AC/minute

温度范围 (Temperature Range): $-45^{\circ}C \sim +125^{\circ}C$

ORDER INFORMATION:

L024-01-T2CB-R			
PART No.			
No. FOR CIRCUITS:	01	PACKAGING:	R=REEL P=PE
PLASTIC MATERIAL:	T2C=PBR (BEIGE)	PLATING:	B=MATTE Sn

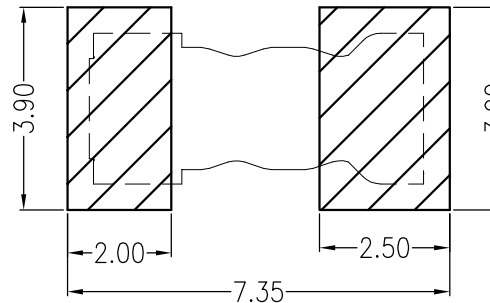
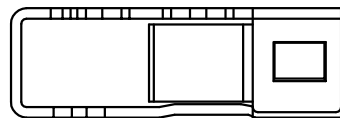

Board Layout

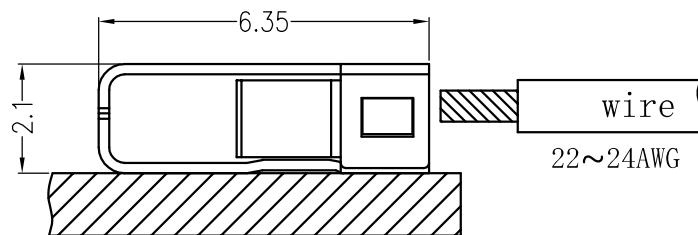

Assembly Layout

ITEM	COMPONENT	Q'TY	MATERIAL	FINISH
C				
B				
A	CONTACT	1 PCS	PhosphorBronze	MATTE Sn-plated
 广东科斯达电子科技有限公司 GUANG DONG KE SI DA ELECTRONIC TECHNOLOGY CO., LTD.				
TITLE: -				
X.±0.5	X.±5'	USE:	CUSTOMER	
.X±0.3	.X±2'	APPD:	邵敬和	
.XX±0.25	.XX±1'	CHKD:	田峰	
--	--	DR:	周秀龙	
UNITS: mm		SCALE	SHEET	
		1 : 1	1 / 1	

A

B

C

D

E

F

REV	DESCRIPTION	DESIGN	DATE
A0	Release	吴丹平	2016.04.30
A/1	增加管控开口尺寸	曾令青	2018.08.22

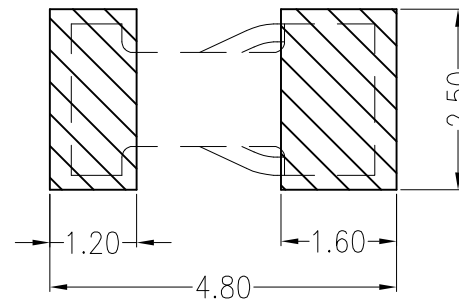
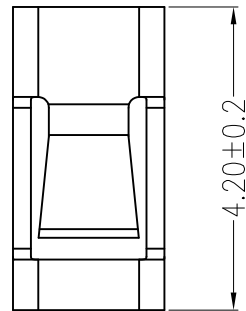
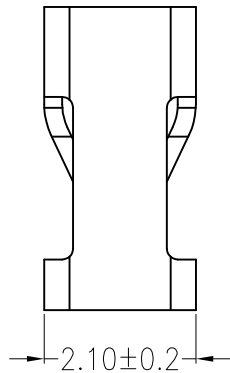
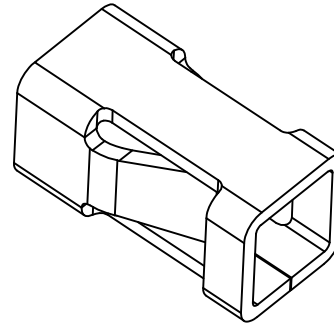
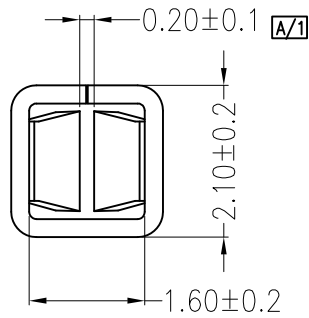

主要技术参数 Main Specifications

线数 (Poles): 01
 接触电阻 (Contact resistance): $\leq 20\text{m}\Omega$
 绝缘电阻 (Insulation resistance):
 额定电压 (Rated voltage): 250 V AC DC
 额定电流 (Rated current): 2.0A AC DC
 耐电压 (Withstand Voltage):
 温度范围 (Temperature Range):

ORDER INFORMATION:

L024B-01-T2CB-R			
PART No.			
No. FOR CIRCUITS:	01		PACKAGING: R=REEL P=PE
PLASTIC MATERIAL:	T2C=PBR (BEIGE)		PLATING: B=MATTE Sn

Board Layout

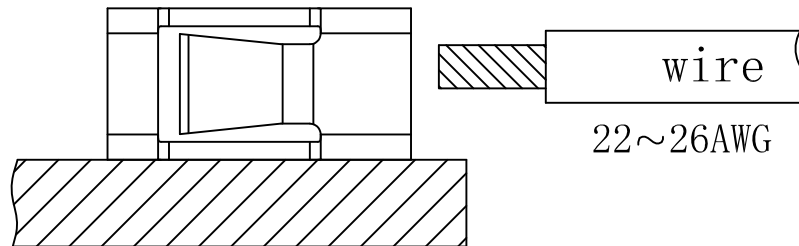

Assembly Layout

ITEM	COMPONENT	Q'TY	MATERIAL	FINISH
C				
B				
A	CONTACT	1 PCS	PhosphorBronze	MATTE Sn-plated
 广东科斯达电子科技有限公司 GUANG DONG KE SI DA ELECTRONIC TECHNOLOGY CO., LTD.				
TITLE: -				
X.±0.5	X.±5'	USE:	PART NO.:	
.X±0.3	.X±2'	APPD:	L024B-01-T2CB-R	
.XX±0.25	.XX±1'	CHKD:	DWG NO.:	
--	--	DR:	JKUN/GCCP-0301	
UNITS: mm		SCALE	SHEET	
		1 : 1	1 / 1	