

REV	DESCRIPTION	DESIGN	DATE
A0	NEW RELEASE	Lingqing	2020/04/17

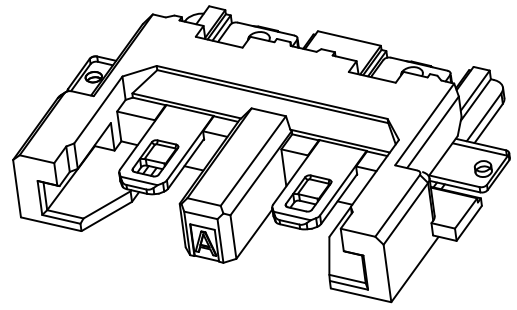

**Specifications:**  
 Contact resistance: ≤30mΩ  
 Insulation resistance: ≥1000MΩ  
 Rated voltage: 400V AC DC  
 Rated current: 2.0A AC DC  
 Withstand Voltage: 1800V AC/minute  
 Temperature Range: -25°C ~ +105°C  
 Housing: PA6T UL94V-0, Natural  
 Contacts: Phosphor Bronze/Sn-plated  
 Solder Tabs: Phosphor Bronze/Sn-plated

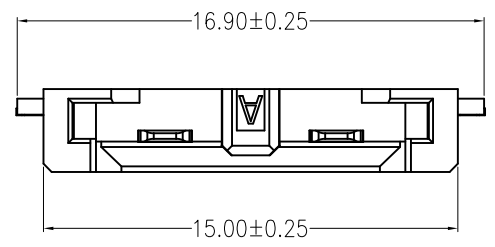
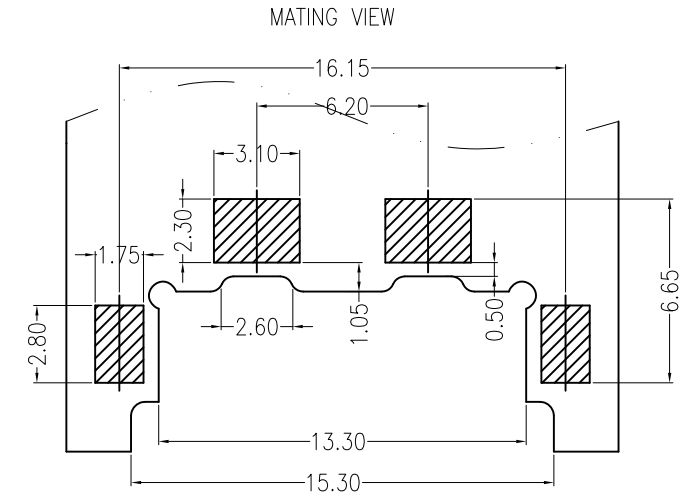
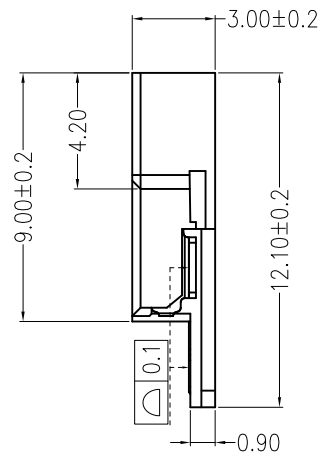
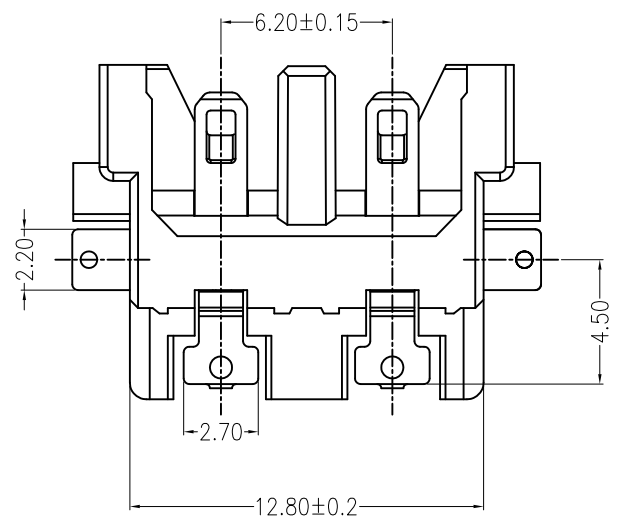
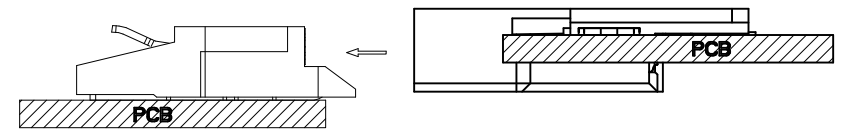

PCB LAYOUT (Tolerance: ±0.05)  
 注: 建议按照推荐焊盘尺寸开PCB板

ORDER INFORMATION:

B6201G-02-C2MA1-R	
PART No.	PACKAGING: R=REEL
No. OF CIRCUITS: 02	Metal code: 1=Phosphor Bronze
PLASTIC MATERIAL: C2M=PA6T	PLATING: A=Sn-plated

<b>广东科斯达电子科技有限公司</b> GUANG DONG KE SI DA ELECTRONIC TECHNOLOGY CO., LTD.		TITLE: 6.2mm Pitch BTB MALE SMT R/A TYPE	
		PART NO.: B6201G-02-C2MA1-R	
GENERAL TOLERANCE		USE: CUSTOMER	
X. ±0.50	X. ±5°	APPD: WangLiang	
X.X ±0.30	X.X ±2°	CHKD: Steven	
X.XX ±0.20	X.XX ±1°	DR: Zenglingqing	
UNITS: mm		SCALE 1 : 1	SHEET 1 / 1