

REV	DESCRIPTION	DESIGN	DATE
A0	Release	吴丹平	2016.04.30

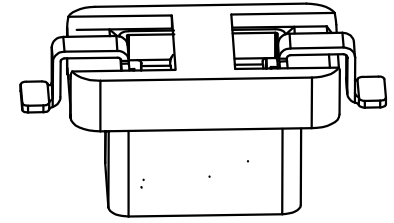
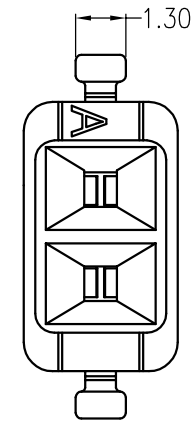
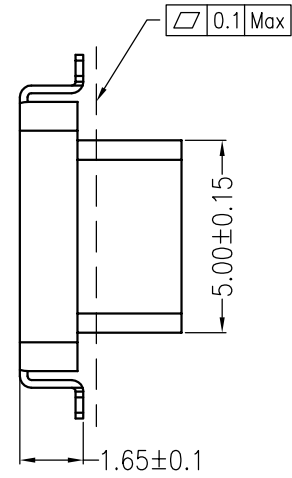
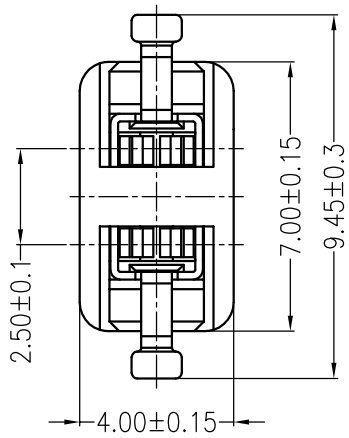

**主要技术参数 Main Specifications**

- 线 数 (Poles): 02
- 接触电阻 (Contact resistance):  $\leq 20m\Omega$
- 绝缘电阻 (Insulation resistance):  $\geq 1000M\Omega$
- 额定电压 (Rated voltage): 275V AC DC
- 额定电流 (Rated current): 1.0A AC DC
- 耐 电压 (Withstand Voltage): 1500V AC/minute
- 温度范围 (Temperature Range):  $-40^{\circ}C \sim +120^{\circ}C$

**ORDER INFORMATION:**

**L055AFV-02-F2MB1-R-5**

PART No.		SPECIAL CODE
No. FOR CIRCUITS:	02	5=方孔插针
PLASTIC MATERIAL:	F2M=LCP (BEIGE)	PACKAGING:
		R=REEL
		P=PE
PLATING:	B=MATTE Sn	Metal code:
		1=Phosphor bronze

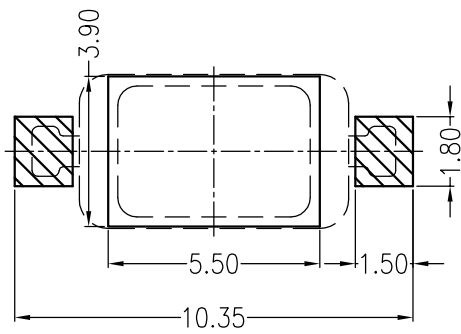
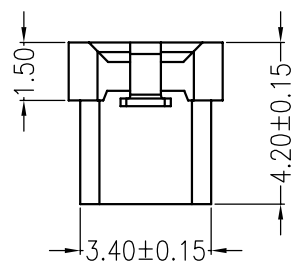

**Board Layout**  
General Tolerance:  $\pm 0.05$

ITEM	COMPONENT	Q'TY	MATERIAL	FINISH
C				
B	CONTACT	2 PCS	PhosphorBronze	MATTE Sn-plated
A	PEDESTAL	1 PCS	LCP	UL 94V-0, COLOR:BEIGE

<b>广东科斯达电子科技有限公司</b> GUANG DONG KE SI DA ELECTRONIC TECHNOLOGY CO., LTD.		<b>TITLE: -</b> 2.5mmPITCH 180°WAFER SMT TYPE	
X.±0.5	X.±5'	<b>USE:</b> CUSTOMER	<b>PART NO.:</b> L055AFV-02-F2MB1-R-5
.X±0.3	.X±2'		
.XX±0.25	.XX±1'	<b>CHKD:</b> 曾令青	<b>DWG NO.:</b> GCCP-1334
---	---		
		<b>UNITS:</b> mm	<b>SHEET</b> 1 / 1

REV	DESCRIPTION	DESIGN	DATE
A0	NEW RELEASE	蒋建银	2019/11/13

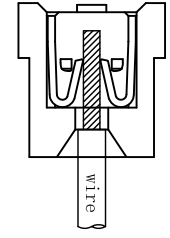
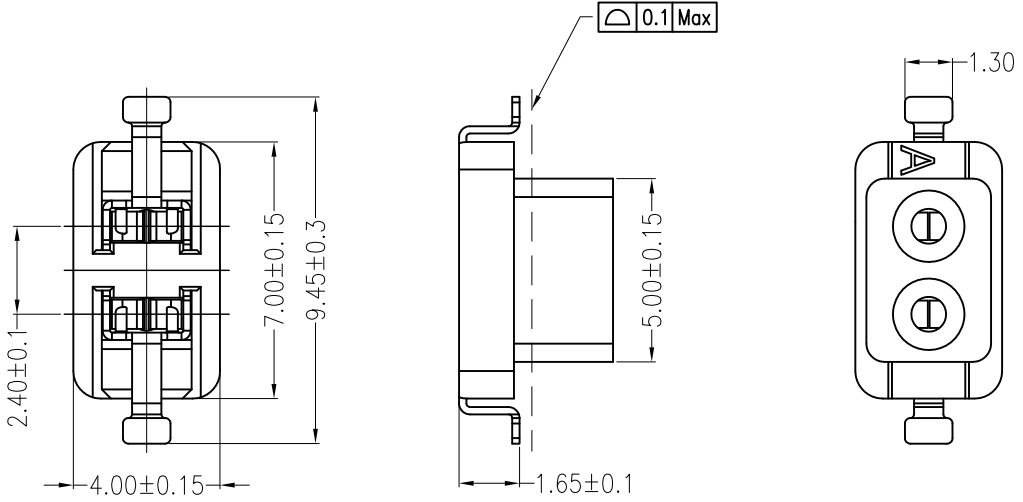

Assembly Layout

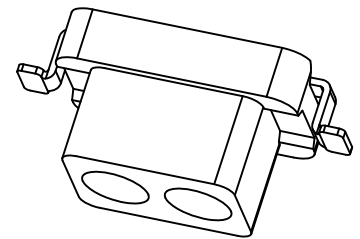

**Specifications:**

- Contact resistance:  $\leq 20m\Omega$
- Insulation resistance:  $\geq 1000M\Omega$
- Rated voltage: 275V AC DC
- Rated current: 1.0A AC DC
- Withstand Voltage: 1500V AC/minute
- Temperature Range:  $-40^{\circ}C \sim +120^{\circ}C$
- Housing: LCP UL94V-0, Natural (Beige)
- Contacts: Phosphor Bronze/Matte Sn-plated

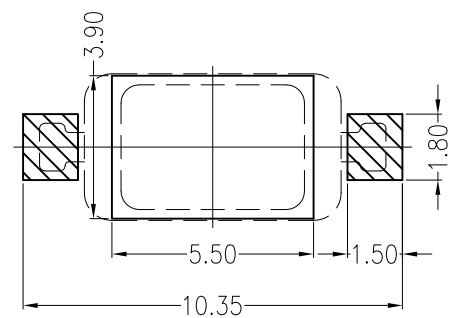
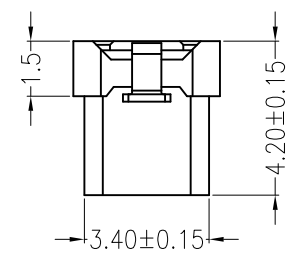

Board Layout  
General Tolerance:  $\pm 0.05$

**ORDER INFORMATION:**

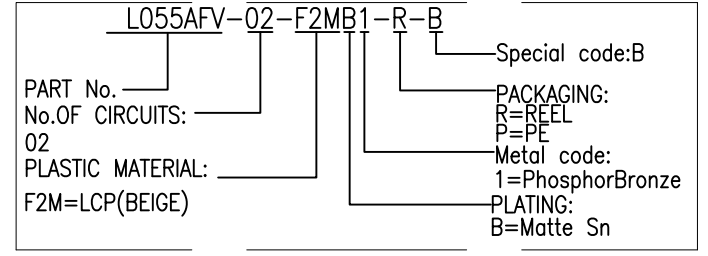

<b>广东科斯达电子科技有限公司</b> GUANG DONG KE SI DA ELECTRONIC TECHNOLOGY CO., LTD.		TITLE: 2.5mmPITCH 180°WAFER SMT TYPE	
		PART NO.: L055AFV-02-F2MB1-R-B	
GENERAL TOLERANCE		USE: CUSTOMER	
X. $\pm 0.50$	X. $\pm 5^{\circ}$	APPD: 刘振岭	
X.X $\pm 0.30$	X.X $\pm 2^{\circ}$	CHKD: 王亮	
X.XX $\pm 0.20$	X.XX $\pm 1^{\circ}$	DR: 蒋建银	
UNITS: mm		SCALE 1 : 1	SHEET 1 / 1