

REV	DESCRIPTION	DESIGN	DATE
A	Release	-	-
-	-	-	-

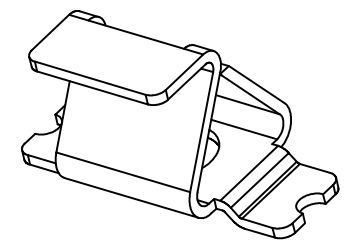

主要技术参数 Main Specifications

- 线数 (Poles): 01
- 接触电阻 (Contact resistance): $\leq 20m\Omega$
- 绝缘电阻 (Insulation resistance):
- 额定电压 (Rated voltage): 250 V AC DC
- 额定电流 (Rated current): 1.0A AC DC
- 耐电压 (Withstand Voltage):
- 温度范围 (Temperature Range):

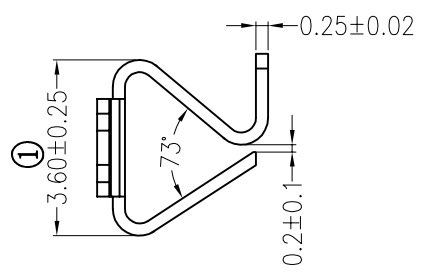
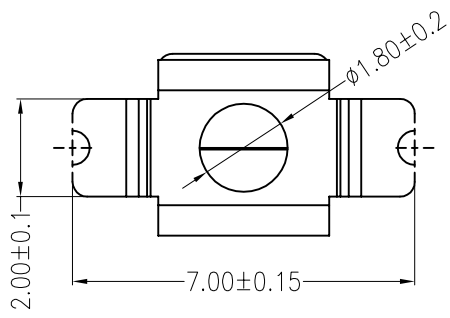
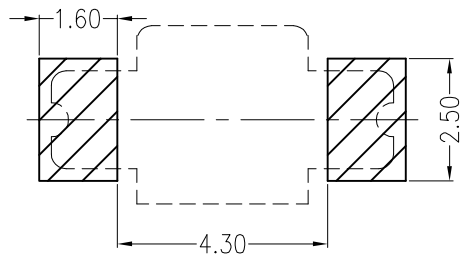
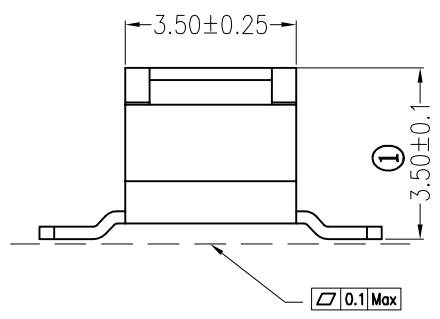

Board Layout

ORDER INFORMATION:

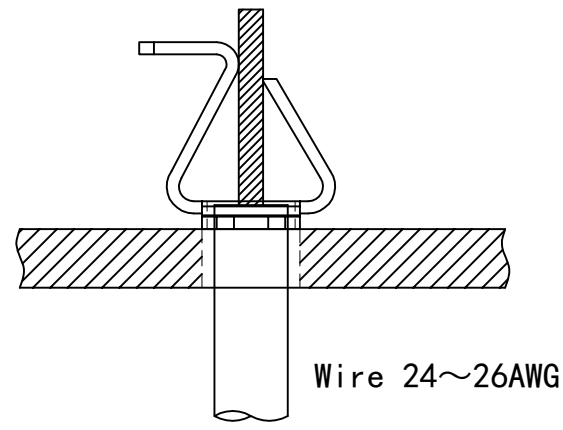
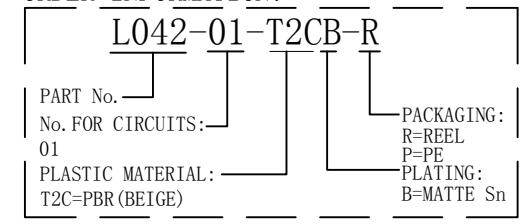

Assembly Layout

ITEM	COMPONENT	Q'TY	MATERIAL	FINISH
A	CONTACT	1 PCS	PhosphorBronze	MATTE Sn -plated

广东科斯达电子科技有限公司 GUANG DONG KE SI DA ELECTRONIC TECHNOLOGY CO., LTD.			TITLE: -	
X.±0.35	X.±	USE: MANUFACTURE	PART NO.:	
.X±0.25	.X±		L042-01-T2CB-R	
.XX±0.15	.XX±	APPD: 邵敬和	DWG NO.:	
--	--	CHKD: 田峰	GCCP-0070	
⊕	◁	UNITS: mm	DR: 蒋建银	SCALE 1 : 1
			SHEET 1 / 1	