

REV	ECN No.	DESCRIPTION	DESIGN	DATE
A0		Release	吴丹平	2017.11.02

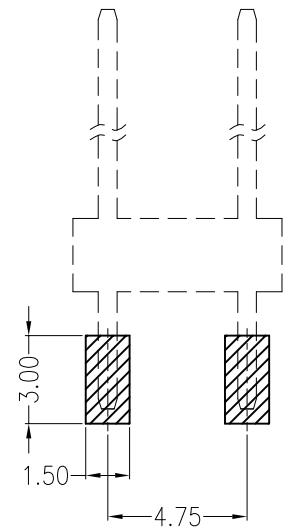
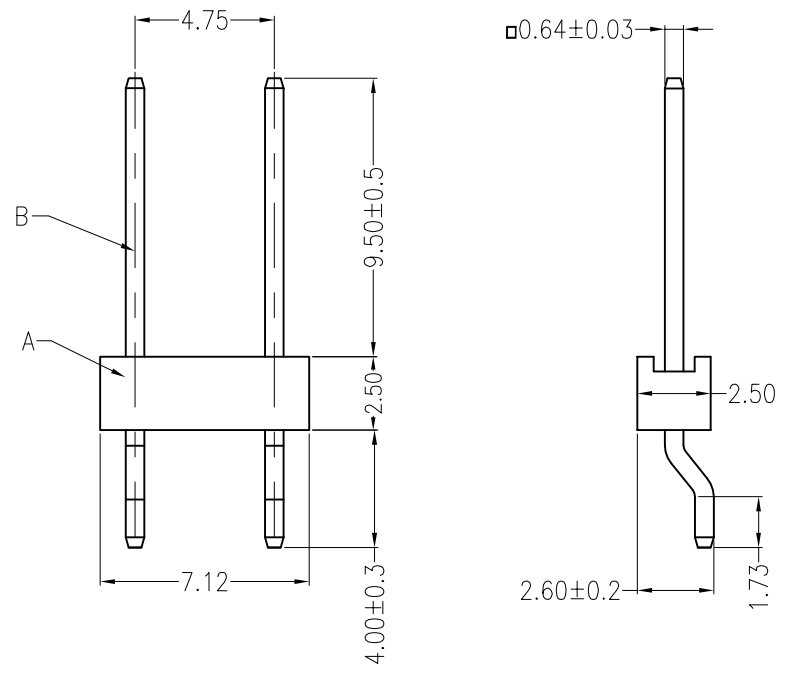

Board Layout
General Tolerance: ± 0.05

主要技术参数 Main Specifications

- 线 数 (Poles): 02 to 10
- 接触电阻 (Contact resistance): $\leq 30m\Omega$
- 绝缘电阻 (Insulation resistance): $\geq 1000M\Omega$
- 额定电压 (Rated voltage): 250V AC DC
- 额定电流 (Rated current): 2.0A AC DC
- 耐 电压 (Withstand Voltage): 1500V AC/minute
- 温度范围 (Temperature Range): $-40^{\circ}C \sim +110^{\circ}C$

ORDER INFORMATION:

L043AWR-02-B1MB2-*--4

PART No.	4=外露针长: 9.5
No.OF CIRCUITS:	PACKAGING: P=PE
PLASTIC MATERIAL:	R=REEL
B1M=PA46(BEIGE)	Metal code: 2=Brass
	PLATING: B=MATTE Sn

ITEM	COMPONENT	Q'TY	MATERIAL	FINISH
C				
B	CONTACT	2 PCS	Brass	MATTE Sn-plated
A	HOUSING	1 PCS	PA46	UL 94V-0, COLOR:BEIGE

广东科斯达电子科技有限公司 GUANG DONG KE SI DA ELECTRONIC TECHNOLOGY CO., LTD.		TITLE: - 4.75mmPITCH 180°WAFER SMT TYPE	
X.±0.5	X.±5'	USE: CUSTOMER APPD: 邵敬和 CHKD: 田 峰 DR: 吴丹平	PART NO.: L043AWR-02-B1MB2-*--4
.X±0.3	.X±2'		DWG NO.: GCCP-1069
.XX±0.25	.XX±1'		
---	---	UNITS: mm	SCALE: 1 : 1
			SHEET: 1 / 1