

A

B

C

D

E

F

REV	DESCRIPTION	DESIGN	DATE
A0	Release	-	-

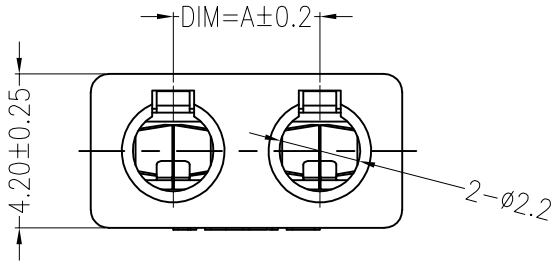

名称	DIM=A	DIM=B
L066K-01		B=4.50
L066K-02	A=4.00	B=8.50
L066K-03	A=8.00	B=12.50

1

1

2

2

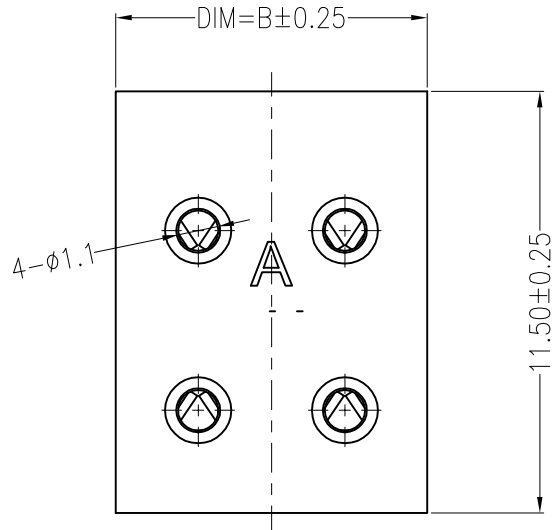

主要技术参数 Main Specifications

线 数 (Poles): 01~03

适用线规 (Applicable Wire): 24~22#

接触电阻 (Contact resistance): $\leq 20m\Omega$

绝缘电阻 (Insulation resistance): $\geq 1000M\Omega$

额定电压 (Rated voltage): 275V AC DC

额定电流 (Rated current): 1A AC DC

耐 电压 (Withstand Voltage): 1000V AC/minute

温度范围 (Temperature Range): $-40^{\circ}C \sim +110^{\circ}C$

ORDER INFORMATION:

L066K-**-B1MA1-P	
PART No. _____	PACKAGING: P=PE
No. OF CIRCUITS: 01~03	PLATING: I=PhosphorBronze
PLASTIC MATERIAL: _____	PLATING: A=Sn
B1M=PA46 (BEIGE)	

3

3

4

4

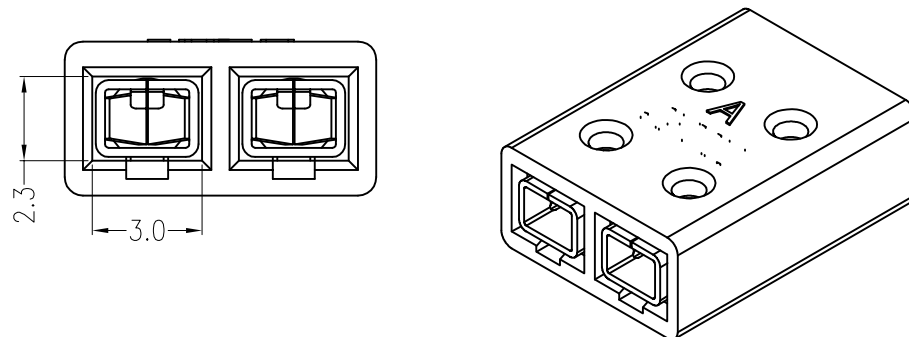

C				
B	CONTACT	1~3 PCS	PhosphorBronze	Sn-plated
A	PEDESTAL	1 PCS	PA46	UL 94V-0, COLOR:BEIGE
ITEM	COMPONENT	Q'TY	MATERIAL	FINISH



广东科斯达电子科技有限公司
GUANG DONG KE SI DA ELECTRONIC TECHNOLOGY CO., LTD.

TITLE: -
4.0mmPITCH

X.±0.5	X.±5'	USE: CUSTOMER	PART NO.:	
.X±0.3	.X±2'		L066K-**-B1MA1-P	
.XX±0.25	.XX±1'	APPD: 邵敬和	DWG NO.:	
--	--	CHKD: 田峰	GCCP-0379	
	UNITS: mm	DR: 吴丹平	SCALE 1 : 1	SHEET 1 / 1

A

B

C

D

E

F

5