

REV	ECN No.	DESCRIPTION	DESIGN	DATE
A0		Release	曾令青	2019.04.03

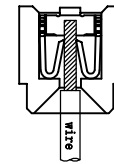

Assembly Layout

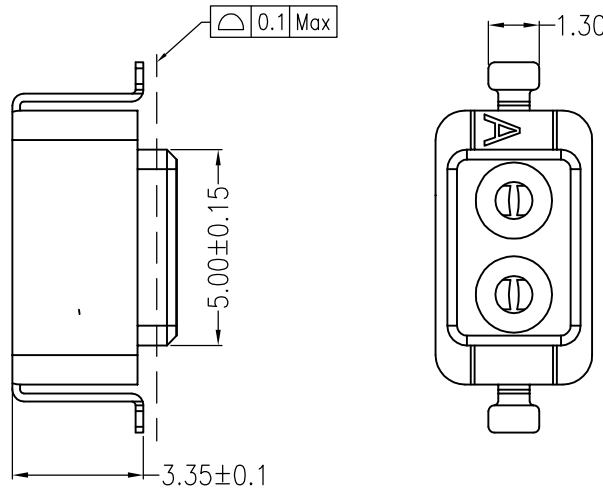
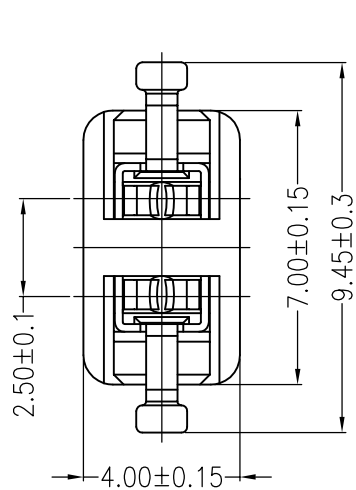
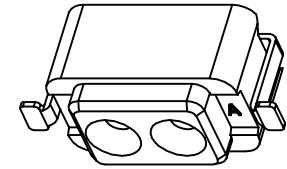

主要技术参数 Main Specifications

- 线数 (Poles): 02
- 接触电阻 (Contact resistance): $\leq 20m\Omega$
- 绝缘电阻 (Insulation resistance): $\geq 1000M\Omega$
- 额定电压 (Rated voltage): 275V AC DC
- 额定电流 (Rated current): 1.0A AC DC
- 耐电压 (Withstand Voltage): 1500V AC/minute
- 温度范围 (Temperature Range): $-40^{\circ}C \sim +120^{\circ}C$

ORDER INFORMATION:

L2503AFV-02-F2MB1-R

PART No. _____
 No. FOR CIRCUITS: _____
 02
 PLASTIC MATERIAL: _____
 F2M=LCP (BEIGE)
 PLATING: _____
 B=MATTE Sn
 PACKAGING: _____
 R=REEL
 P=PE
 Metal code: _____
 1=Phosphor bronze

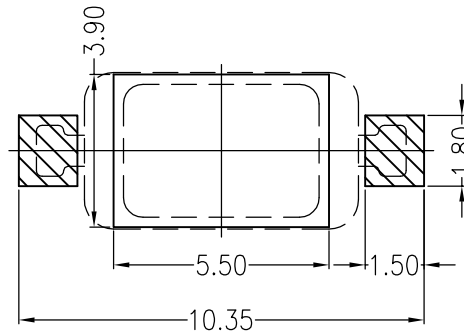
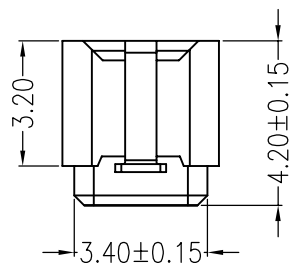

Board Layout
General Tolerance: ± 0.05

ITEM	COMPONENT	Q'TY	MATERIAL	FINISH
C				
B	CONTACT	2 PCS	Phosphor bronze	TIN-plated
A	PEDESTAL	1 PCS	LCP	UL 94V-0, COLOR:BEIGE

广东科斯达电子科技有限公司 GUANG DONG KE SI DA ELECTRONIC TECHNOLOGY CO., LTD.		TITLE: 2.5mmPITCH 180°WAFER SMT TYPE	
X.±0.5	X.±5'	USE:	PART NO.:
.X±0.3	.X±2'	CUSTOMER	L2503AFV-02-F2MB1-R
.XX±0.25	.XX±1'	APPD: 邵敬和	DWG NO.:
--	--	CHKD: 曾令青	GCKH-1382
UNITS: mm	DR: 蒋建银	SCALE 1 : 1	SHEET 1 / 1